

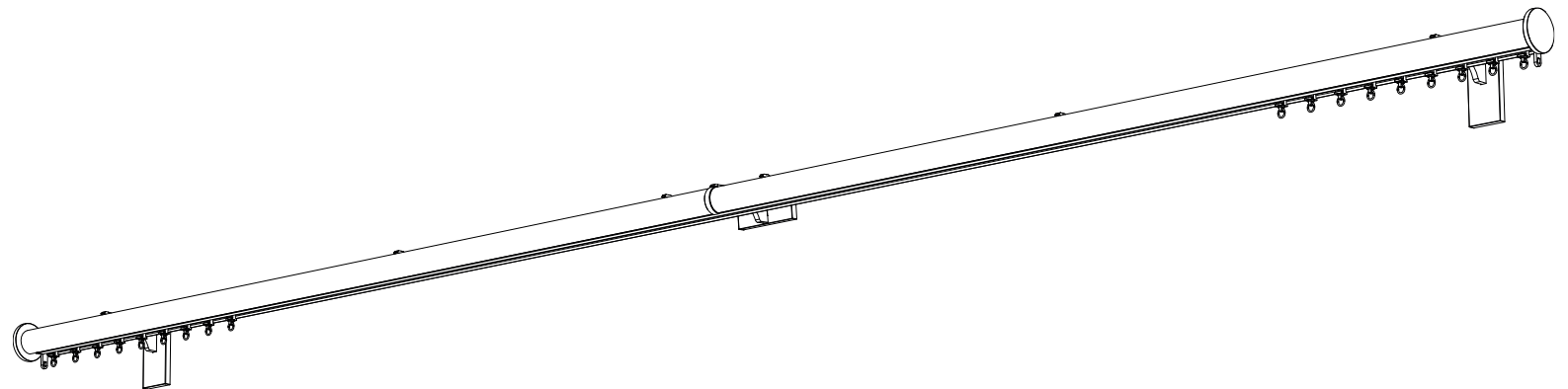

the **bradley** collection

ECLIPSE HAND DRAWN

Installation Instructions



CONTACT

Web www.bradleycollection.com

Email info@bradleycollection.com

Follow     

WORLD

The Bradley Collection Ltd
Lion Barn • Maitland Road
Needham Market • Suffolk
IP6 8NS • UK

Telephone +44 (0)1449 722 724

Fax +44 (0)1449 722 728

USA & Canada

The Bradley Collection Inc.
3625 Hayden Avenue, Suite E
Culver City • CA • 90232 • USA

Telephone +1 (310) 815 8255

Fax +1 (310) 815 9255

ECLIPSE HAND DRAWN

Installation Instructions

THANK YOU FOR YOUR ORDER

Before fitting this product please ensure that you have thoroughly read these instructions.

We have taken every care to design and manufacture a quality system; incorrect installation could lead to poor performance.

If any queries arise when reviewing these instructions or during installation please feel free to contact us for assistance. We will be glad to talk you through the process.

Please retain these instructions for future reference.

CONTACT

Web www.bradleycollection.com

Email info@bradleycollection.com

World +44 (0)1449 722 724

USA & Canada +1 (310) 815 8255

Follow     

Fixings

As a courtesy we have supplied a set of fixings for the system.

These screws and wall plugs are designed to be used in wood and brick walls. We understand our systems may be used on a variety of materials; drywall, aluminium and steel stud, or lath and plaster.

To properly secure a system onto these or other types of surfaces; appropriate fixings must be independently obtained.

! Assess your own wall construction and source the appropriate screw type.
! Please note that the enclosed fixings may not be suitable for all wall types.

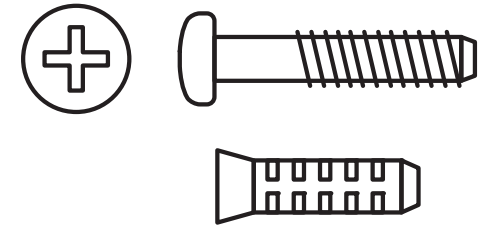

Tools

For the installation of the system the following items may be required.

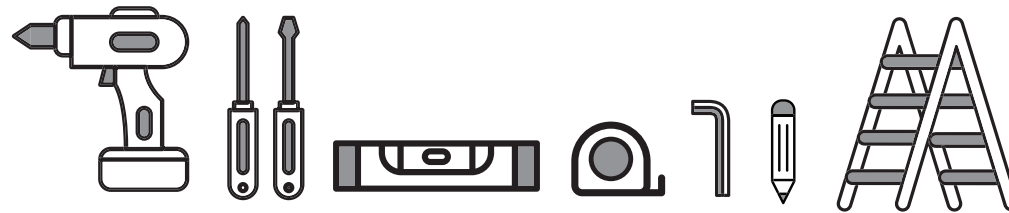

Care & Maintenance

This pole can be cleaned using a soft cloth and furniture polish.

! Please do not use any solvent or chlorine based cleaners as this will damage the finish.

Bracket positioning and fixing

Side brackets should be positioned approximately 100mm (4") in from the end of the pole.

Single Brackets

To align the brackets, the top of the mid brackets should be fitted inline with the top of the side brackets.

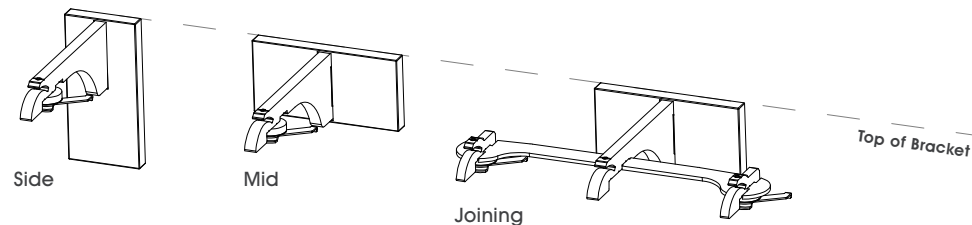

Finials

Attach the finials by locating the tab in the coverpole and screwing into position until secure. Make sure not to over tighten.

Fitting the coverpole

Roll the coverpole into the bracket arm and tighten the set screw.

It is recommended to fit the coverpole first.

Intermediate support clamps

On long lengths or curtain stack points, we may supply intermediate clamps. These are fitted between brackets and stop the track drooping away from the cover pole.

Joining the pole

Where coverpoles are made in two parts. Push pole ends into the joining sleeve and push the poles together. The coverpole can then drop be rolled into the bracket arm.

Care and maintenance

This system can be cleaned using a soft cloth and furniture polish.

Please do not use any solvent or chlorine based cleaners as this will damage the finish.

Bracket positioning & fixing

Brackets should be positioned approximately 100mm (4") from the ends of the pole. Where a system is made in two or more parts, joins should be supported by joining brackets.

Detailed bracket assembly can be seen on the following pages.

Joining the track

Where tracks are made in two parts. Push track ends into the joiner and push the track together. Ensuring not to track the belt. Turn the clamps at the end of the joiner to secure.

The belt will need to be joined together. Belts join at the overlap arm.

Fitting the track

The track sits on the underside of the brackets, to fit offer the track up and turn the swivel clamps until there is a positive click.

When fitting the track ensure the higher edge of the profile is at the front.

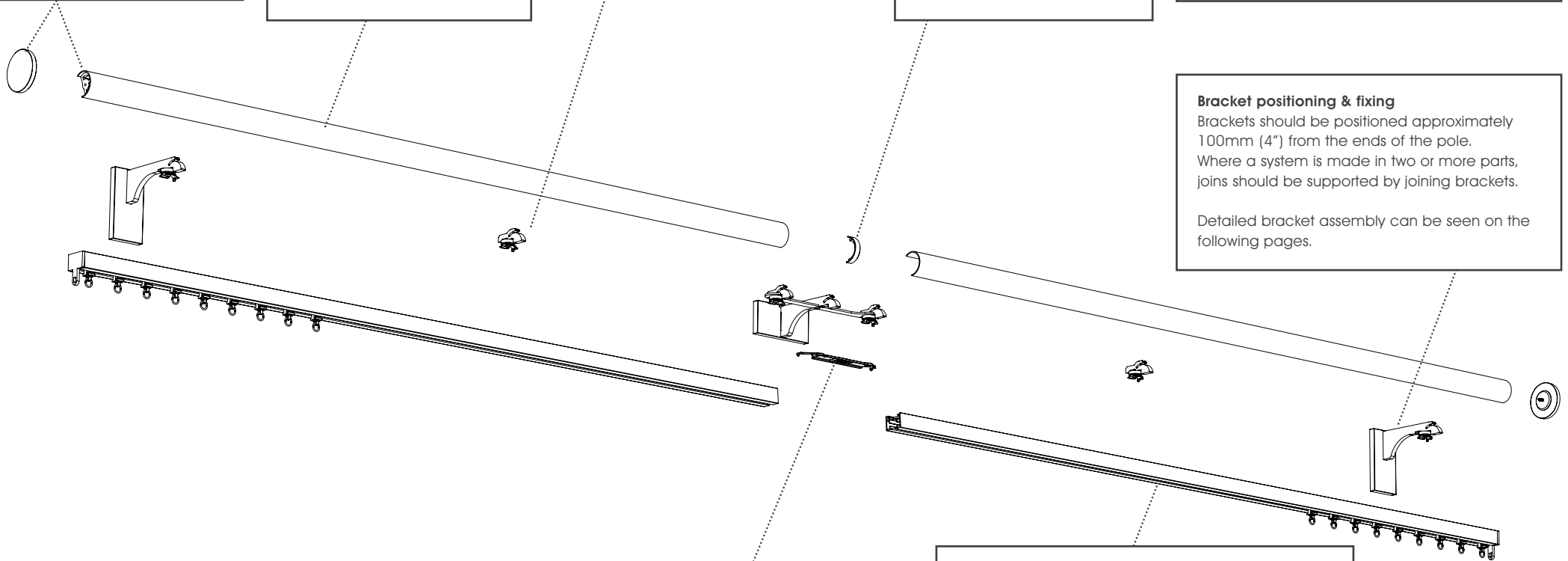

Single Brackets - Side & Mid

1. Mark the position of the brackets.
2. Drill holes & insert plugs.
3. Screw each bracket into position.
4. Push cover plate over arm, the cover is held in place by magnets.
5. Screw the swivel clamp to the bracket arm, ensuring all the screws are secure.

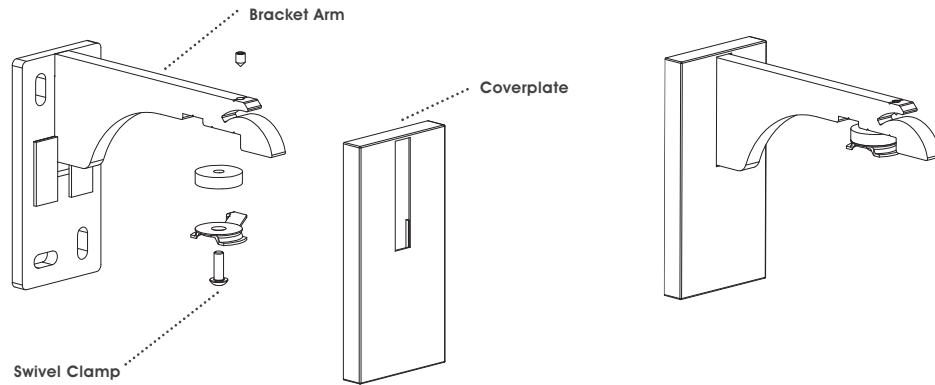

Single Brackets - Joining

1. Mark the position of the brackets.
2. Drill holes & insert plugs.
3. Screw each bracket into position.
4. Push cover plate over arm, the cover is held in place by magnets.
5. Screw the joining bridge to the bracket arm, ensuring all the screws are secure.

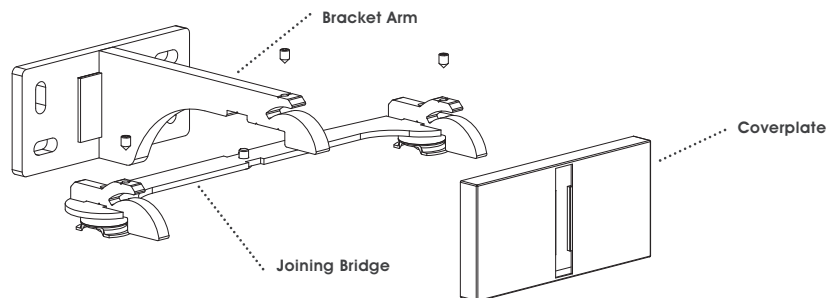

Flush Ceiling Brackets

1. Mark the position of the brackets.
2. Drill holes & insert plugs.
3. Screw each bracket into position.
4. Push cover plate over arm, the cover is held in place by magnets.

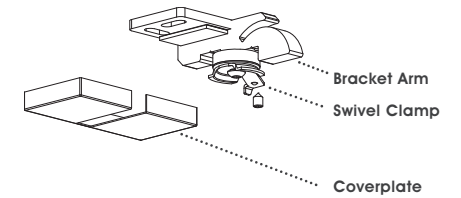

Fitting coverpole and track

1. The cover pole sits into bracket arm. Locate in the correct position and tighten the set screw on the underside of the bracket arm.
2. The track sits on the underside of the brackets, to fit offer the track up and turn the swivel clamps until there is a positive click.

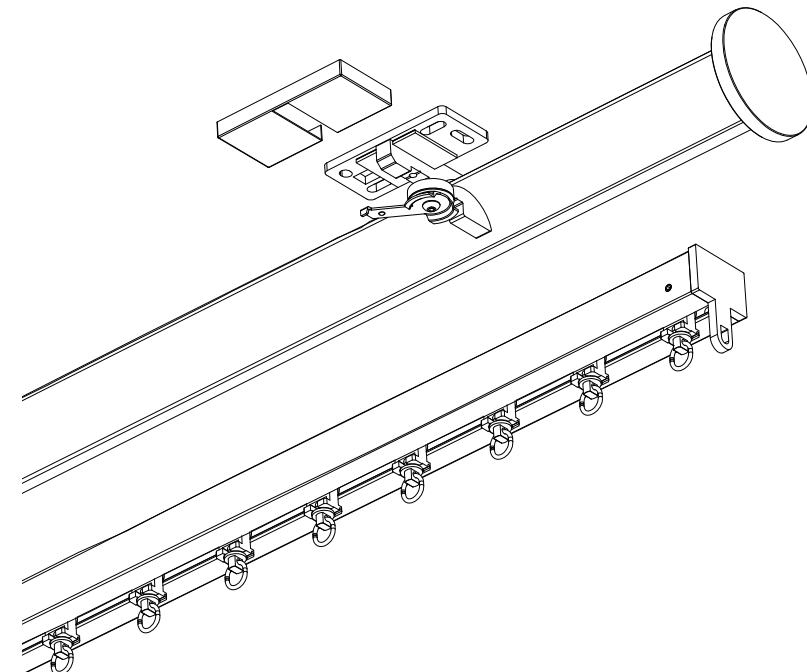

Please note, bracket assembly may vary slightly between diameters from the diagram above.