

the**bradley**collection

ECLIPSE
ELECTRIC
SOMFY

Specification Guide

ECLIPSE ELECTRIC SOMFY

Specification Guide

CONTENTS

How to order 02-05

Diameters 06-07

Finishes 08-11

Finials 12-40

Progressive 12-21

Classic 22-27

Deco 28-40

Brackets 41-52

Single Brackets 43-46

Ceiling Brackets 47-48

Double Brackets 49-51

Somfy 53-79

Coverpole & Electric Track Information 54-57

Track configuration & Stacking Locations 58-61

Coverpole & Track 62-66

Bay Bends 67-68

Curtain Drops 69-70

Curtain Information 71-72

Maximum Weight Recommendations 73

Motors & Controls 74-79

Hand Drawn 80-99

CONTACT

Web www.bradleycollection.com

Email info@bradleycollection.com

World +44 (0)1449 722 724

USA & Canada +1 (310) 815 8255

Follow



the**bradley**collection

This specification guide was designed to outline the main considerations that need to be made when quoting or ordering a system.

The guide is laid out to be worked through while completing the quote & order form. the form can be downloaded at

www.bradleycollection.com/support/quote-order-forms.

If any questions arise please call your local sales representative or contact The Bradley Collection directly.

ECLIPSE How to Order • Order Form - Page 1

For us to process your request efficiently, please fax or email back a fully completed quote and order form.

Shown is a filled in example of a quote & order form.

Forms can be downloaded at

www.bradleycollection.com/support/quote-order-forms/

1 Diameter Choose the diameter.

2 Finishes Choose required finish.

3 Finials Choose required finials.

4 Brackets Choose bracket style and projection.

ECLIPSE Electric • Quote & Order Form Date 1st August 2019

Customer Day Associates Kings Road Chelsea	Telephone 02034 567890 Fax 02034 567891 Email info@dayassociates.com Contact Name Robyn	Job Name / PO Number Jones View PO-07654	Representative Contact Name
------------------------------------------------------------	------------------------------------------------------------------------------------------------------------------------------------------	-------------------------------------------------------	--------------------------------------------------

PLEASE ANSWER ALL OF THE FOLLOWING QUESTIONS TO ENSURE AN ACCURATE QUOTE

1 Diameter

<input type="checkbox"/> Progressive 30mm (1 3/16")	<input type="checkbox"/> Classic 30mm (1 3/16")	<input type="checkbox"/> Deco Brass 50mm (2")
<input checked="" type="checkbox"/> Progressive 38mm (1 1/2")	<input type="checkbox"/> Classic 38mm (1 1/2")	<input type="checkbox"/> Deco Wood 50mm (2")
<input type="checkbox"/> Progressive 50mm (2")	<input type="checkbox"/> Classic 50mm (2")	

2 Finishes

<input type="checkbox"/> Alabaster (M-S-G-P)	<input type="checkbox"/> Dusk (M-S-G-P)	<input type="checkbox"/> Granite (M-S-G-P)	<input type="checkbox"/> Slate (M-S-G-P)	<input type="checkbox"/> Flint (M-S-G-P)
<input type="checkbox"/> Barley (M-S-G-P)	<input type="checkbox"/> Dove (M-S-G-P)	<input type="checkbox"/> Millstone (M-S-G-P)	<input type="checkbox"/> Clay (M-S-G-P)	<input type="checkbox"/> Cocoa (M-S-G-P)
<input type="checkbox"/> Cloud (M-S-G-P)	<input type="checkbox"/> Ceramic (M-S-G-P)	<input checked="" type="checkbox"/> Bone (M-S-G-P)	<input type="checkbox"/> Cream (M-S-G-P)	<input type="checkbox"/> Parchment (M-S-G-P)
<input type="checkbox"/> Damson (M-S-G-P)	<input type="checkbox"/> Moss (M-S-G-P)	<input type="checkbox"/> Smoke (M-S-G-P)	<input type="checkbox"/> Frame Grey (M-S-G-P)	<input type="checkbox"/> Raven (M-S-G-P)
<input type="checkbox"/> Platinum (S-E)	<input type="checkbox"/> Champagne (S-E)	<input type="checkbox"/> Gold (S-E)	<input type="checkbox"/> Cognac (S-E)	<input type="checkbox"/> Gunmetal (S-E)
<input type="checkbox"/> Pewter (S-E)	<input type="checkbox"/> Antique Brass (S-E)	<input type="checkbox"/> Bronzed (S-E)		<input type="checkbox"/> Custom. Please specify

Coat Option Matte (M) Satin (S) Glass (G) Paint over tulip wood (P)

Progressive Additional Finishes

<input type="checkbox"/> Brushed Stainless	<input type="checkbox"/> Brushed Brass Tint	<input type="checkbox"/> Brushed Bronze Tint	<input type="checkbox"/> Brushed Carbon Tint
--------------------------------------------	---------------------------------------------	----------------------------------------------	----------------------------------------------

Classic Additional Finishes

<input type="checkbox"/> Polished	<input type="checkbox"/> Natural Steel	<input type="checkbox"/> Brass Toned	<input type="checkbox"/> Matte Brass Toned	<input type="checkbox"/> Oil Rubbed
-----------------------------------	----------------------------------------	--------------------------------------	--------------------------------------------	-------------------------------------

Deco Additional Finishes

<input type="checkbox"/> Aged Brass	<input type="checkbox"/> Waxed Brass	<input type="checkbox"/> Polished Brass
-------------------------------------	--------------------------------------	-----------------------------------------

Deco - Finial & bracket only finishes

Polished Nickel

Deco - Wood coverpole & finial only finishes

<input type="checkbox"/> Aged Oak	<input type="checkbox"/> Jacobean Oak	<input type="checkbox"/> Mahogany	<input type="checkbox"/> Ebony
-----------------------------------	---------------------------------------	-----------------------------------	--------------------------------

3 Finials

<input type="checkbox"/> Flush End Cap* Quantity _____	<input checked="" type="checkbox"/> Contrast stud Quantity <u>2</u>	<input type="checkbox"/> Large Disc Quantity _____
<input type="checkbox"/> Octagon Stud Quantity _____	<input type="checkbox"/> Ball Quantity _____	<input type="checkbox"/> Crystal Ball Quantity _____
<input type="checkbox"/> Faceted Disc Quantity _____	<input type="checkbox"/> Pebble Quantity _____	<input type="checkbox"/> Squat Disc Quantity _____
Classic		
<input type="checkbox"/> Flush End Cap* Quantity _____	<input type="checkbox"/> Standard Stud Quantity _____	<input type="checkbox"/> Large Stud Quantity _____
<input type="checkbox"/> Button Stud Quantity _____	<input type="checkbox"/> Ball & Collar Quantity _____	
Deco		
<input type="checkbox"/> Flush End Cap* Quantity _____	<input type="checkbox"/> Contrast stud Quantity _____	<input type="checkbox"/> Wooden Contrast stud Quantity _____
<input type="checkbox"/> Flute Quantity _____	<input type="checkbox"/> Squat Ball Quantity _____	<input type="checkbox"/> Wooden Squat Ball Quantity _____
<input type="checkbox"/> Templar Quantity _____	<input type="checkbox"/> Crystal Templar Quantity _____	<input type="checkbox"/> Wooden Templar Quantity _____
<input type="checkbox"/> Discus Quantity _____	<input type="checkbox"/> Ribbed Sphere Quantity _____	<input type="checkbox"/> Wooden Ribbed Sphere Quantity _____

4 Brackets

<input checked="" type="checkbox"/> Single - Side Quantity <u>2</u>	<input checked="" type="checkbox"/> Single - Mid Quantity <u>1</u>	<input type="checkbox"/> Single - Joining Quantity _____
<input type="checkbox"/> Double - Side Quantity _____	<input type="checkbox"/> Double - Mid Quantity _____	<input type="checkbox"/> Double - Joining Quantity _____
<input type="checkbox"/> Flush Ceiling Quantity _____	<input type="checkbox"/> Flush Ceiling - Joining Quantity _____	

PLEASE TURN OVER

thebradleycollection

0120 Wave® is a registered trademark of Silent Giles Ltd.

Web www.bradleycollection.com
Email info@bradleycollection.com

World
Telephone +44 (0)1449 722 724
Fax +44 (0)1449 722 728

USA & Canada
Telephone +1 (310) 815 8255
Fax +1 (310) 815 9255

2

ECLIPSE How to Order • Order Form - Page 2

For us to process your request efficiently, please fax or email back a fully completed quote and order form.

Forms can be downloaded at www.bradleycollection.com/support/quote-order-forms/

Shown is a filled in example of a quote & order form.

- 5 Coverpole Information** State required coverpole length and stacking location
- 6 Curtain Information** Fill in the total curtain Weight in section A. If unknown, answer questions B-E and Bradley will calculate the curtain Weight.
- 7 Motor** specify motor location, and control options.
- 8 Order Declaration** Sign and date the form

ECLIPSE Electric • Quote & Order Form

Date 1st August 2019

Customer <u>Jones View</u> <u>PO-07654</u>	Telephone
	Fax
	Email
	Contact Name

PLEASE ANSWER ALL OF THE FOLLOWING QUESTIONS TO ENSURE AN ACCURATE QUOTE

5 Pole Length & Information

A **Straight Pole Length** 2875mm (113 3/16")
Please give measurements of Pole length only, see diagram A. If this is not possible please follow diagram B.



preferred option



Pole Length Pole & Finial Length

Bay Pole - Please fill in Bay Form

B Stacking Location
Please specify how the curtain will be stacked.



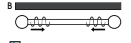

Single Stack Pair Stack

Wave® header tape & hooks required

6 Curtain Information

A Total Curtain Weight _____
Please fill in questions B-E, if this information is not available

These questions allow us to calculate curtain weight, if not noted above.

B Heading

Standard

Wave/Ripple

Ripplefold

C Curtain Drop 2525mm (99")

E Fabric

Light - Cotton / Linen

Medium - Cotton / Linen

Heavy - Velvet / Wool

F Lining

None

Lined

Interlined

7 Motor, Control & Gliding Options

Silent Gliss 5100

5190 - White
Plastic housing will be supplied in White

Motor Location

Left

Right

Controlled by

Hand Remote - Single Channel

Hand Remote - Multi Channel

Wall Remote - Single Channel

Wall Remote - Multi Channel

Wall Timer - Single Channel

Wall Timer - Multi Channel

Gliding Options

Rollers

Wave® Gliders

Silent Gliss 5600

9060 - Silver
Plastic housing will be supplied in Grey

9060 - White
Plastic housing will be supplied in White

Motor Location

Left

Right

Controlled by

Radio Module
Required for control with remote & app controls

Hand Remote - Single Channel

Hand Remote - Multi Channel (5+1)

Hand Remote - Multi Channel (10+2+1)

Hand Remote - Multi Channel (15+5+1)

App Control - Move Server Set

Home Automation - Smart Integration

Gliding Options

Gliders

Rollers

Wave® Gliders

Wave® Rollers

Somfy

Movelite 35 WT - White

Movelite 35 DCT - White

Movelite 35 RTS - White

Glydea Ultra 60e WT - White

Glydea Ultra 60e DCT - White

Glydea Ultra 60e RTS - White

Ilesmo RTS - White - White
Plastic housing will be supplied in White

Motor Location

Left

Right

Powered by

Ilesmo Charger

Controlled by

Wall Remote - Single Channel

Hand Remote - Multi Channel

App Control - Tahoma

Home Automation

Gliding Options

Rollers

Ripple Rollers

Lutron Sivoia

D105

D145

D175
Plastic housing will be supplied in White

Motor Location

Left

Right

Powered by

Transformer

Other

Controlled by

Radio Dongle
Required for control with remote & app controls

Hand Remote - Single Channel

Hand Remote - Multi Channel (5+1)

App Control - RA2 Select Hub

Home Automation

Gliding Options

Rollers

Ripplefold® Rollers - 80% Fullness

Ripplefold® Rollers - 100% Fullness

Ripplefold® Rollers - 120% Fullness

Hand drawn Available on request

8 Order Declaration I confirm the given information & measurements are correct and on this basis wish to proceed with an ORDER.

Signed Robyn Day

Date 1st August 2019

thebradleycollection

0120 Wave® is a registered trademark of Silent Gliss Ltd.

Web www.bradleycollection.com

Email info@bradleycollection.com

World

Telephone +44 (0)1449 722 724

Fax +44 (0)1449 722 728

USA & Canada

Telephone +1 (310) 815 8255

Fax +1 (310) 815 9255

3

ECLIPSE How to Order • Bay Order Form

- When ordering a bay, a bay measuring form must be completed in addition to a quote and order form.
- Before going into production, all bays are mathematically checked. If it is found that the measurements are out of Bradley's tolerances, the measurements will need to be rechecked. accurate measurements are critical to having a perfect fitting bay.
- Standard bays are shown; more complex bays are also available. In some instances, a template will be required. Templates are always required on continuous curves that are not a perfect curve. On more complicated bays, a CAD drawing will be provided. if supplied, Bradley can also work with client CAD files.
- All bays that come in more than one part are joined with connectors; Joins must always be supported with a bracket. If there are any requirements on where the joins need to be placed, please specify this on the order form.
- Bays are packed in sections and pole ends are labelled consecutively for ease of fitting.

Shown is a filled in example of a bay measuring form.

- 1 Directions for measuring a bay** Read the directions, if there are any questions concerning the correct way to take wall measurements, please contact us.
- 2 Collection & Diameter** Select the collection Select the type of bay and fill in the measurements.
- 3 Details** Specify the finial location, and if the pole is a ceiling mounted or a double pole.
- 4 Order Declaration** Sign and date the form. Bay orders will not be accepted without these items complete.

BAY Cross Dimensions • Measuring Form

Date 1st August 2019



Bay Checker
Bays can also be measured using our bay checker app
Scan here or search for bay checker in iTunes & Google Play

Customer <u>Day Associates</u> <u>Kings Road</u> <u>Chelsea</u>	Telephone <u>02034 567890</u> Fax <u>02034 567891</u> Email <u>info@dayassociates.com</u> Contact Name <u>Robyn</u>
---------------------------------------------------------------------------------	----------------------------------------------------------------------------------------------------------------------------------------------------------------------

Directions for measuring a bay

1 Use a metal tape measure and ensure you have help.	2 Measure the wall at the height the pole will be fitted.	3 Mark measuring points lightly with pencil to ensure consistency.	4 Measure wall dimensions not pole dimensions.
------------------------------------------------------	-----------------------------------------------------------	--------------------------------------------------------------------	------------------------------------------------

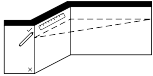

1 Collection & Diameter

Gliderpole <input type="checkbox"/> Flat H36mm (1 7/16") - Hand Drawn <input type="checkbox"/> Square H27mm (1 1/16") - Hand Drawn/Corded <input type="checkbox"/> Round 30mm (1 3/16") - Hand Drawn/Corded <input type="checkbox"/> Round 50mm (2") - Hand Drawn/Corded	Steel <input type="checkbox"/> 19mm (3/4") <input type="checkbox"/> 25mm (1") <input type="checkbox"/> 38mm (1 1/2") <input type="checkbox"/> 50mm (2")	Simple <input type="checkbox"/> 19mm (3/4") <input type="checkbox"/> 25mm (1") <input type="checkbox"/> 30mm (1 3/16") <input type="checkbox"/> 38mm (1 1/2") <input type="checkbox"/> 50mm (2")	Stainless <input type="checkbox"/> 19mm (3/4") <input type="checkbox"/> 25mm (1") <input type="checkbox"/> 38mm (1 1/2") <input type="checkbox"/> 50mm (2")	Elysian <input type="checkbox"/> 30mm (1 3/16") <input type="checkbox"/> 50mm (2") Deco <input type="checkbox"/> 50mm (2")	Eclipse <input checked="" type="checkbox"/> 38mm (1 1/2")* <input type="checkbox"/> 50mm (2")* <small>* Select finish & track options only</small>
---------------------------------------------------------------------------------------------------------------------------------------------------------------------------------------------------------------------------------------------------------------------------------------------	----------------------------------------------------------------------------------------------------------------------------------------------------------------------------	------------------------------------------------------------------------------------------------------------------------------------------------------------------------------------------------------------------------	--------------------------------------------------------------------------------------------------------------------------------------------------------------------------------	------------------------------------------------------------------------------------------------------------------------------------------------------	------------------------------------------------------------------------------------------------------------------------------------------------------------------------

2 Bay Type & Measurement Please pick the bay type and complete the corresponding measurements

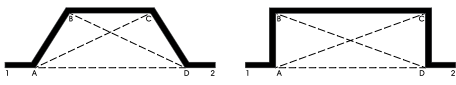
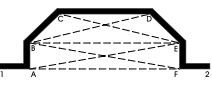
<input checked="" type="checkbox"/> One Bend Bay 	Wall Measurements	<table border="1" style="width: 100%;"> <tr> <td style="width: 50%;">A-B <u>1180mm</u></td> <td style="width: 50%;">A-C <u>2343mm</u></td> </tr> <tr> <td>B-C <u>2059mm</u></td> <td></td> </tr> </table>	A-B <u>1180mm</u>	A-C <u>2343mm</u>	B-C <u>2059mm</u>									
A-B <u>1180mm</u>	A-C <u>2343mm</u>													
B-C <u>2059mm</u>														
<input type="checkbox"/> Two Bend Bay <input type="checkbox"/> Square Bay 	Wall Measurements	<table border="1" style="width: 100%;"> <tr> <td>A-B</td> <td>A-C</td> </tr> <tr> <td>B-C</td> <td>A-D</td> </tr> <tr> <td>C-D</td> <td>B-D</td> </tr> </table>	A-B	A-C	B-C	A-D	C-D	B-D						
A-B	A-C													
B-C	A-D													
C-D	B-D													
<input type="checkbox"/> Four Bend Bay 	Wall Measurements	<table border="1" style="width: 100%;"> <tr> <td>A-B</td> <td>B-D</td> </tr> <tr> <td>B-C</td> <td>C-E</td> </tr> <tr> <td>C-D</td> <td>B-E</td> </tr> <tr> <td>D-E</td> <td>A-E</td> </tr> <tr> <td>E-F</td> <td>B-F</td> </tr> <tr> <td></td> <td>A-F</td> </tr> </table>	A-B	B-D	B-C	C-E	C-D	B-E	D-E	A-E	E-F	B-F		A-F
A-B	B-D													
B-C	C-E													
C-D	B-E													
D-E	A-E													
E-F	B-F													
	A-F													

Optional distances for return bends
See specification guide for min. wall space required

1-A
2-D

Optional distances for return bends
See specification guide for min. wall space required

1-A
2-F

3 Finial Location

Please confirm where you would like your finials <input checked="" type="checkbox"/> 1 Outside point A <input type="checkbox"/> 2 Inside point A <input type="checkbox"/> 3 Distance from point A	If option 3, please specify distance from point A <input style="width: 50px;" type="text"/>	Ceiling Mounted? <input type="checkbox"/> Yes <input checked="" type="checkbox"/> No If yes, please specify projection from wall <input style="width: 50px;" type="text"/>	Double Pole <input type="checkbox"/> Yes <input checked="" type="checkbox"/> No
------------------------------------------------------------------------------------------------------------------------------------------------------------------------------------------------------	------------------------------------------------------------------------------------------------	----------------------------------------------------------------------------------------------------------------------------------------------------------------------------------------------------	-------------------------------------------------------------------------------------------

4 Order Declaration please ensure all sections are complete and note that errors made on this form could mean your bay system will not fit correctly, bay systems cannot be exchanged, replaced or refunded.
I confirm the given measurements are correct and on this basis wish to proceed with an ORDER

Signed <u>Robyn Day</u>	Date <u>1st August 2019</u>
-------------------------	-----------------------------

thebradleycollection

Web www.bradleycollection.com
Email info@bradleycollection.com

World
Telephone +44 (0)1449 722 724
Fax +44 (0)1449 722 728

USA & Canada
Telephone +1 (310) 815 8255
Fax +1 (310) 815 9255

0819

ECLIPSE How to Order • Bay Checker App



Bradley's bay checker app available from the App Store and Google Play.

Primarily for use by interior designers and fitters, the simple step-by-step guide and check functionality means that your clients could also provide reliable self-measurements if required.

Suitable for pole or track projects, including optional return bend measurements.

A genuine time saver as the job of measuring only ever needs doing once.

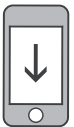

Download

Scan QR above or visit the app store or google play



Measure

Help with measuring bays ensuring we have all the measurements we need



Check

Built-in checking facility gives instant confirmation that measurements have been taken and entered correctly.



Quote

Includes quotation request facility

Standard bay shapes

Our bay check app covers all standard bay shapes.



one bend



two bend



square

DIAMETERS

ECLIPSE Diameter

Poles are manufactured to suit individual requirements. When calculating the length of your pole, remember to allow tolerance beyond the width of the frame for the curtains to draw back to the edge of the window.

Maximum pole length in one piece 2.9m (114").

Poles exceeding the recommended maximum distance between brackets, will be cut into equal parts unless otherwise specified. Pole joiners will be supplied. Joining brackets should be placed at every join.

SOMFY®

Available pole diameter's - $\varnothing 38\text{mm}$ (1½") • $\varnothing 50\text{mm}$ (2")

The overall pole cost is rounded up in 300mm (1ft) increments.

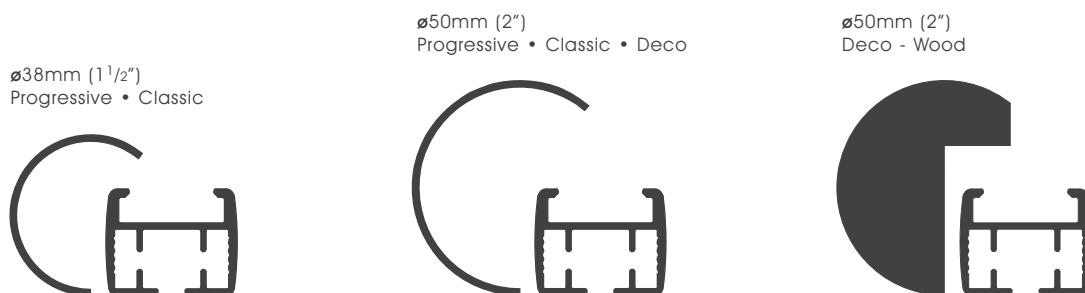

Motor Type	Maximum System Length - Single Stack →	Maximum System Length - Pair Stack →←	Maximum Coverpole Section Length	Maximum Track Section Length	Bracket Spacing
Glydea 60 WT RTS	12000mm (39')	12000mm (39')	2900mm (9'6")	3000mm (10')	1500mm (5')
Irismo 45 WF RTS	10000mm (32.5')	10000mm (32.5')	2900mm (9'6")	3000mm (10')	1500mm (5')

HAND DRAWN

For windows or double treatments where motorisation is not required, a hand drawn option is available.
See Page 87

FINISHES

ECLIPSE Finishes

Metal poles and components may all be finished in this entire palette of subtle colour coats in matte, satin or gloss finishes and metallic coats in satin or gloss.

Progressive, Classic and Deco elements each have some additional specific finishes, based on their inherent material properties. These specialist finishes on the following pages.

Coat Options Matte (M) • Satin (S) • Gloss (G) • Paint over Tulip Wood (P)

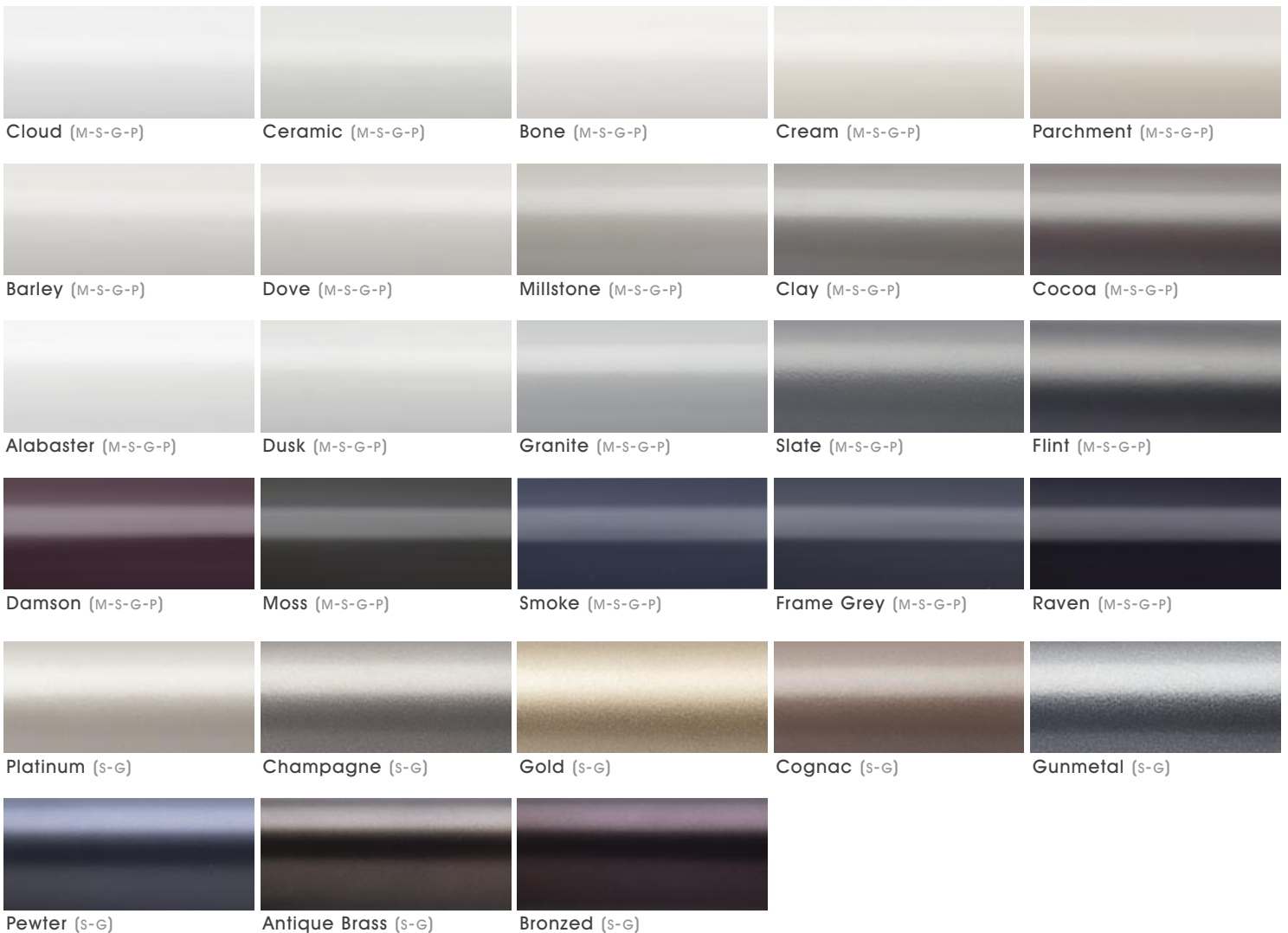

Due to printing limitations colours in this brochure may not be accurate
Samples are available on request - www.bradleycollection.com/samples/

M Matte finishes have a maximum section length of 2.4m (94")
+ A finishing charge will apply ⊕ Longer lead-times will apply ^ Not available on Square or 50mm (2") poles

Custom Finishes

Can be specified subject to a per colour upcharge

Custom Colour charge per order



ECLIPSE Finishes

Classic Finishes Additional to those shown on page 12



Polished

Natural Steel

Brass Toned

Matte Brass Toned

Oil Rubbed

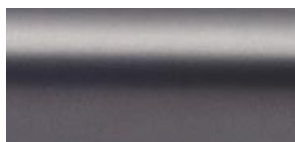

Waxed

Progressive Finishes Additional to those shown on page 12

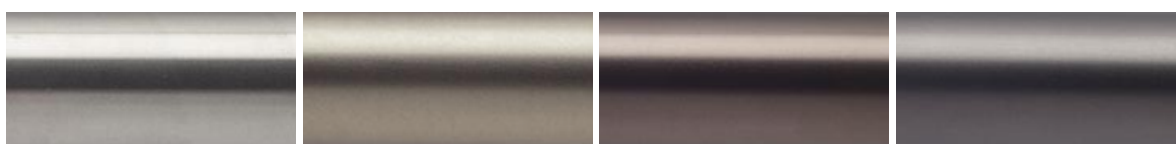

Brushed Stainless

Brushed Brass Tint

Brushed Bronze Tint

Brushed Carbon Tint

Deco Finishes Additional to those shown on page 12



Aged Brass*

Waxed Brass

Polished Brass*

* Brass finishes are supplied unlacquered & will tarnish over time a clear lacquer may be applied on request as a custom finish.

Finial & bracket finishes only



Polished Nickel⁺Ⓢ

Wood coverpole & finial finishes only

Other wood stained finishes are available on request.

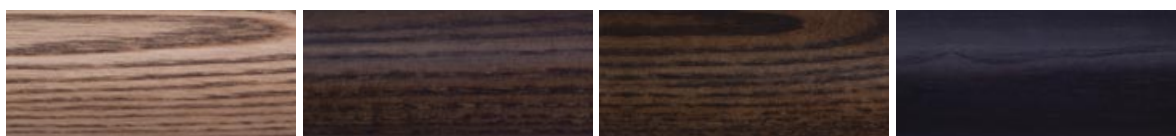

Aged Oak
Stain Over Ash

Jacobean Oak
Stain Over Ash

Mahogany
Stain Over Ash

Ebony
Stain Over Ash

Due to printing limitations colours in this brochure may not be accurate samples are available on request - www.bradleycollection.com/samples/

+ A finishing charge will apply Ⓢ Longer lead-times will apply

ECLIPSE Finishes • Internal Track Colour

Track will be finished in a complementary colour to match the cover pole as per the table below.

Coat Options Matte (M) • Satin (S) • Gloss (G) • Paint over Tulip Wood (P)

	Coverpole Finish	Internal Track
	Cloud (M-S-G-P)	Cloud (M-S-G)
	Ceramic (M-S-G-P)	Ceramic (M-S-G)
	Bone (M-S-G-P)	Bone (M-S-G)
	Cream (M-S-G-P)	Cream (M-S-G)
	Parchment (M-S-G-P)	Parchment (M-S-G)
	Barley (M-S-G-P)	Barley (M-S-G)
	Dove (M-S-G-P)	Dove (M-S-G)
	Millstone (M-S-G-P)	Millstone (M-S-G)
	Clay (M-S-G-P)	Clay (M-S-G)
	Cocoa (M-S-G-P)	Cocoa (M-S-G)
	Alabaster (M-S-G-P)	Alabaster (M-S-G)
	Dusk (M-S-G-P)	Dusk (M-S-G)
	Granite (M-S-G-P)	Granite (M-S-G)
	Slate (M-S-G-P)	Slate (M-S-G)
	Flint (M-S-G-P)	Flint (M-S-G)
	Damson (M-S-G-P)	Damson (M-S-G)
	Moss (M-S-G-P)	Moss (M-S-G)
	Smoke (M-S-G-P)	Smoke (M-S-G)
	Frame Grey (M-S-G-P)	Frame Grey (M-S-G)
	Raven (M-S-G-P)	Raven (M-S-G)
	Platinum (S-G)	Platinum (S-G)
	Champagne (S-G)	Champagne (S-G)
	Gold (S-G)	Gold (S-G)
	Cognac (S-G)	Cognac (S-G)
	Gunmetal (S-G)	Gunmetal (S-G)
	Pewter (S-G)	Pewter (S-G)
	Antique Brass (S-G)	Antique Brass (S-G)
	Bronzed (S-G)	Bronzed (S-G)
Progressive	Brushed Stainless Steel	Natural Silver
	Brushed Brass Tint	Brass Tint
	Brushed Bronze Tint	Bronze Tint
	Brushed Carbon Tint	Carbon Tint
Classic	Polished	Polished Tint
	Natural Steel	Polished Tint
	Brass Toned	Brass Toned
	Matte Brass Toned	Matte Brass Toned
	Oil Rubbed	Oil Rubbed
	Waxed	Waxed
Deco	Aged Brass	Antique Brass
	Waxed Brass	Antique Brass
	Polished Brass	Antique Brass
	Aged Oak	To match metal components
	Jacobean Oak	To match metal components
	Antique Mahogany	To match metal components
	Ebony	To match metal components

FINIALS
PROGRESSIVE

ECLIPSE Finials • End Cap

Finishes Alabaster • Dusk • Granite • Slate • Flint • Barley • Dove • Millstone • Clay • Cocoa • Cloud • Ceramic • Bone • Cream • Parchment • Damson • Moss • Smoke • Frame Grey • Raven
Coat Options Matte (M) • Satin (S) • Gloss (G) • Platinum • Champagne • Gold • Cognac • Gunmetal • Antique Brass • Pewter • Bronzed
Coat Options Satin (S) • Gloss (G)
Progressive (Additional to above) Brushed Stainless • Brushed Brass Tint • Brushed Bronze Tint • Brushed Carbon Tint

The end cap can be specified free of charge as an integral part of the coverpole.

Please note that if this option is selected finials can not be added at a later date.

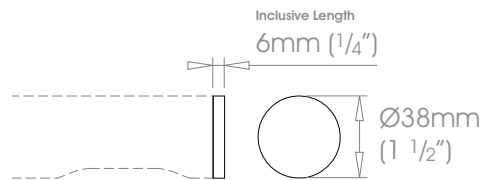

30mm (1 3/16") Not Available

! 30mm (1 3/16") available with Silent Gliss 5600 & Hand Drawn Options only

38mm (1 1/2") End Cap

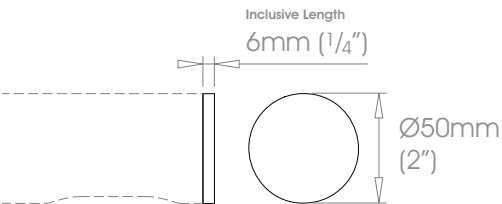

50mm (2") End Cap

ECLIPSE Finials • Progressive - Contrast Stud

Finishes Alabaster • Dusk • Granite • Slate • Flint • Barley • Dove • Millstone • Clay • Cocoa • Cloud • Ceramic • Bone • Cream • Parchment • Damson • Moss • Smoke • Frame Grey • Raven
Coat Options Matte (M) • Satin (S) • Gloss (G) • Platinum • Champagne • Gold • Cognac • Gunmetal • Antique Brass • Pewter • Bronzed
Coat Options Satin (S) • Gloss (G)
Progressive (Additional to above) Brushed Stainless • Brushed Brass Tint • Brushed Bronze Tint • Brushed Carbon Tint

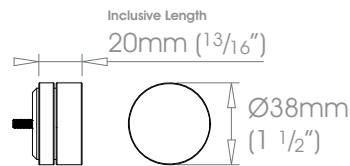

30mm (1 3/16") Not Available

! 30mm (1 3/16") available with Silent Gliss 5600 & Hand Drawn Options only

38mm (1 1/2") Progressive - Contrast Stud

W Weight 193g (7oz)

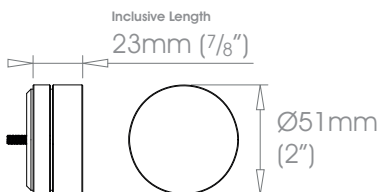

50mm (2") Progressive - Contrast Stud

W Weight 399g (14oz)

ECLIPSE Finials • Progressive - Disc

Finishes Alabaster • Dusk • Granite • Slate • Flint • Barley • Dove • Millstone • Clay • Cocoa • Cloud • Ceramic • Bone • Cream • Parchment • Damson • Moss • Smoke • Frame Grey • Raven
Coat Options Matte (M) • Satin (S) • Gloss (G) Platinum • Champagne • Gold • Cognac • Gunmetal • Antique Brass • Pewter • Bronzed
Coat Options Satin (S) • Gloss (G)
Progressive (Additional to above) Brushed Stainless • Brushed Brass Tint • Brushed Bronze Tint • Brushed Carbon Tint

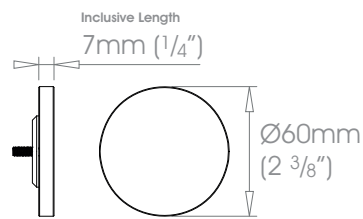

30mm (1 3/16") Not Available

! 30mm (1 3/16") available with Silent Gliss 5600 & Hand Drawn Options only

38mm (1 1/2") Progressive - Disc

W Weight 174g (6oz)

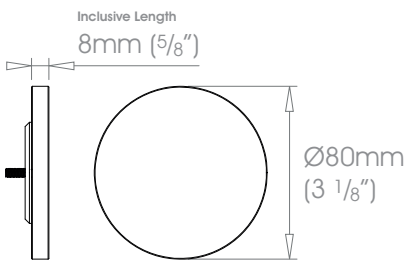

50mm (2") Progressive - Disc

W Weight 353g (12.5oz)

ECLIPSE Finials • Progressive - Octagon Stud

Finishes Alabaster • Dusk • Granite • Slate • Flint • Barley • Dove • Millstone • Clay • Cocoa • Cloud • Ceramic • Bone • Cream • Parchment • Damson • Moss • Smoke • Frame Grey • Raven **Coat Options** Matte (M) • Satin (S) • Gloss (G) Platinum • Champagne • Gold • Cognac • Gunmetal • Antique Brass • Pewter • Bronzed **Coat Options** Satin (S) • Gloss (G)
Progressive (Additional to above) Brushed Stainless • Brushed Brass Tint • Brushed Bronze Tint • Brushed Carbon Tint

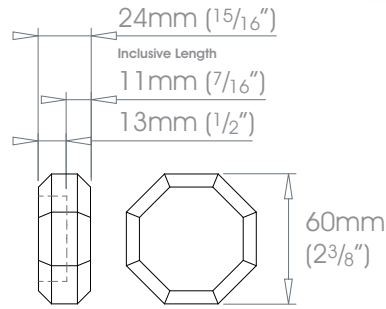

30mm (1 3/16") Not Available

! 30mm (1 3/16") available with Silent Gliss 5600 & Hand Drawn Options only

38mm (1 1/2") Octagon Stud

W Weight 383g (13.5oz)

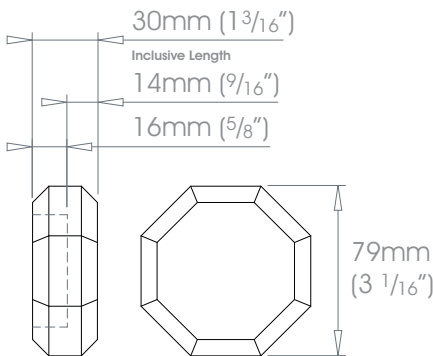

50mm (2") Octagon Stud

W Weight 823kg (11lb 13oz)

ECLIPSE Finials • Progressive - Ball

Finishes Alabaster • Dusk • Granite • Slate • Flint • Barley • Dove • Millstone • Clay • Cocoa • Cloud • Ceramic • Bone • Cream • Parchment • Damson • Moss • Smoke • Frame Grey • Raven **Coat Options** Matte (M) • Satin (S) • Gloss (G) Platinum • Champagne • Gold • Cognac • Gunmetal • Antique Brass • Pewter • Bronzed **Coat Options** Satin (S) • Gloss (G)
Progressive (Additional to above) Brushed Stainless • Brushed Brass Tint • Brushed Bronze Tint • Brushed Carbon Tint

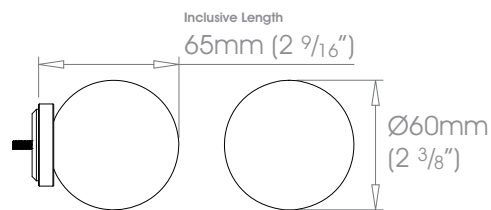

30mm (1 3/16") Not Available

! 30mm (1 3/16") available with Silent Gliss 5600 & Hand Drawn Options only

38mm (1 1/2") Progressive - Ball

W Weight 165g (6oz)

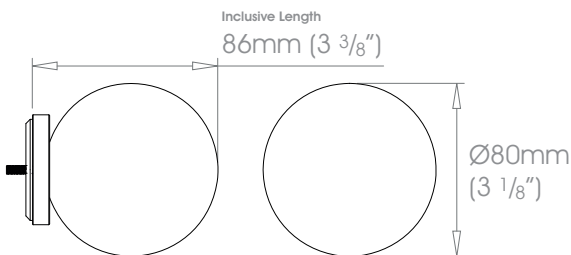

50mm (2") Progressive - Ball

W Weight 317g (11oz)

ECLIPSE Finials • Progressive - Crystal Ball

Finishes Alabaster • Dusk • Granite • Slate • Flint • Barley • Dove • Millstone • Clay • Cocoa • Cloud • Ceramic • Bone • Cream • Parchment • Damson • Moss • Smoke • Frame Grey • Raven **Coat Options** Matte (M) • Satin (S) • Gloss (G) Platinum • Champagne • Gold • Cognac • Gunmetal • Antique Brass • Pewter • Bronzed **Coat Options** Satin (S) • Gloss (G)
Progressive (Additional to above) Brushed Stainless • Brushed Brass Tint • Brushed Bronze Tint • Brushed Carbon Tint

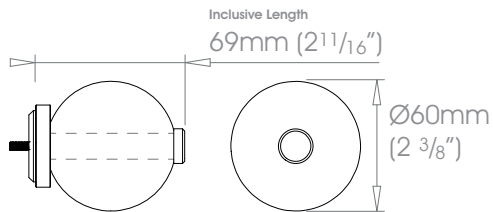

30mm (1 3/16") Not Available

! 30mm (1 3/16") available with Silent Gliss 5600 & Hand Drawn Options only

38mm (1 1/2") Crystal Ball

W Weight 394g (14oz)

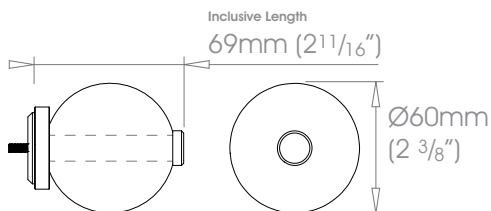

50mm (2") Crystal Ball

W Weight 820g (1lb 13oz)

⚠ Crystal finials should not be positioned in direct sunlight, and are not suitable for use in conservatories

ECLIPSE Finials • Progressive - Faceted Disc

Finishes Alabaster • Dusk • Granite • Slate • Flint • Barley • Dove • Millstone • Clay • Cocoa • Cloud • Ceramic • Bone • Cream • Parchment • Damson • Moss • Smoke • Frame Grey • Raven **Coat Options** Matte (M) • Satin (S) • Gloss (G) Platinum • Champagne • Gold • Cognac • Gunmetal • Antique Brass • Pewter • Bronzed **Coat Options** Satin (S) • Gloss (G)
Progressive (Additional to above) Brushed Stainless • Brushed Brass Tint • Brushed Bronze Tint • Brushed Carbon Tint

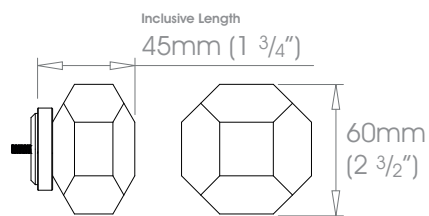

30mm (1 3/16") Not Available

! 30mm (1 3/16") available with Silent Gliss 5600 & Hand Drawn Options only

38mm (1 1/2") Faceted Disc

W Weight 776g (1lb 11oz)

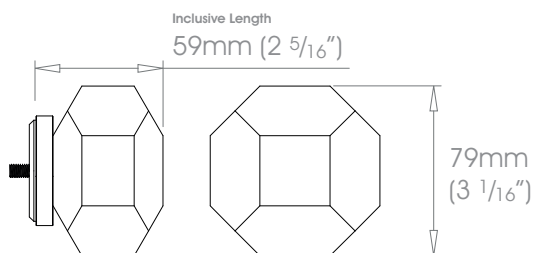

50mm (2") Faceted Disc

W Weight 1.76kg (lb 14oz)

ECLIPSE Finials • Progressive - Pebble

Finishes Alabaster • Dusk • Granite • Slate • Flint • Barley • Dove • Millstone • Clay • Cocoa • Cloud • Ceramic • Bone • Cream • Parchment • Damson • Moss • Smoke • Frame Grey • Raven **Coat Options** Matte (M) • Satin (S) • Gloss (G) Platinum • Champagne • Gold • Cognac • Gunmetal • Antique Brass • Pewter • Bronzed **Coat Options** Satin (S) • Gloss (G)
Progressive (Additional to above) Brushed Stainless • Brushed Brass Tint • Brushed Bronze Tint • Brushed Carbon Tint

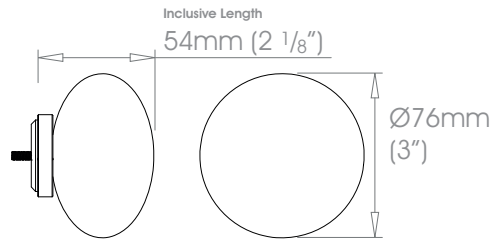

30mm (1 3/16") Not Available

! 30mm (1 3/16") available with Silent Gliss 5600 & Hand Drawn Options only

38mm (1 1/2") Pebble

W Weight 763g (1lb 11oz)

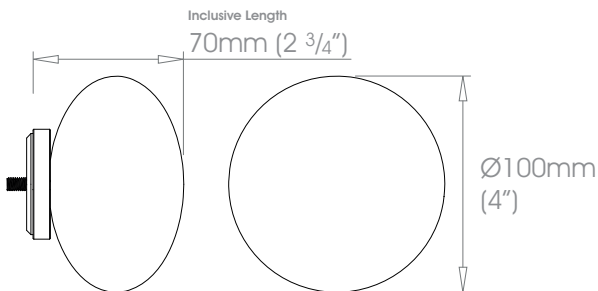

50mm (2") Pebble

W Weight 1.73g (3lb 13oz)

ECLIPSE Finials • Progressive - Squat Disc

Finishes Alabaster • Dusk • Granite • Slate • Flint • Barley • Dove • Millstone • Clay • Cocoa • Cloud • Ceramic • Bone • Cream • Parchment • Damson • Moss • Smoke • Frame Grey • Raven **Coat Options** Matte (M) • Satin (S) • Gloss (G) Platinum • Champagne • Gold • Cognac • Gunmetal • Antique Brass • Pewter • Bronzed **Coat Options** Satin (S) • Gloss (G)
Progressive (Additional to above) Brushed Stainless • Brushed Brass Tint • Brushed Bronze Tint • Brushed Carbon Tint

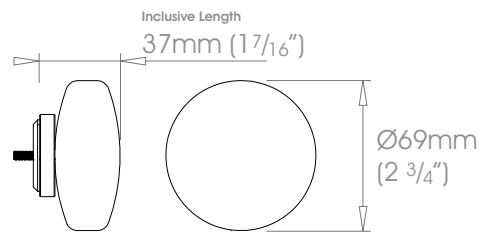

30mm (1 3/16") Not Available

! 30mm (1 3/16") available with Silent Gliss 5600 & Hand Drawn Options only

38mm (1 1/2") Squat Disc

W Weight 763g (1lb 11oz)

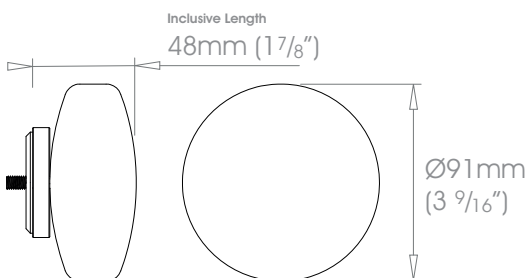

50mm (2") Squat Disc

W Weight 1.73g (3lb 13oz)

FINIALS
CLASSIC

ECLIPSE Finials • Classic - End Cap

Finishes Alabaster • Dusk • Granite • Slate • Flint • Barley • Dove • Millstone • Clay • Cocoa • Cloud • Ceramic • Bone • Cream • Parchment • Damson • Moss • Smoke • Frame Grey • Raven **Coat Options** Matte (M) • Satin (S) • Gloss (G) Platinum • Champagne • Gold • Cognac • Gunmetal • Antique Brass • Pewter • Bronzed **Coat Options** Satin (S) • Gloss (G)
Classic (Additional to above) Polished • Natural Steel • Brass Toned • Matte Brass Toned • Oil Rubbed • Waxed

The end cap can be specified free of charge as an integral part of the coverpole.

Please note that if this option is selected finials can not be added at a later date.

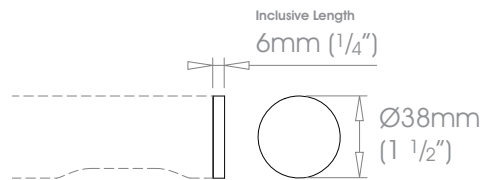

30mm (1 3/16") Not Available

! 30mm (1 3/16") available with Silent Gliss 5600 & Hand Drawn Options only

38mm (1 1/2") End Cap

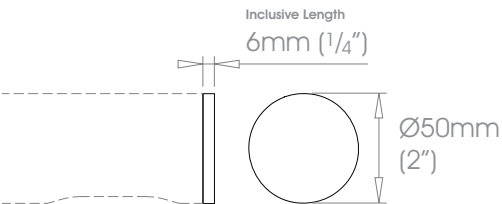

50mm (2") End Cap

ECLIPSE Finials • Classic - Stud

Finishes Alabaster • Dusk • Granite • Slate • Flint • Barley • Dove • Millstone • Clay • Cocoa • Cloud • Ceramic • Bone • Cream • Parchment • Damson • Moss • Smoke • Frame Grey • Raven
Coat Options Matte (M) • Satin (S) • Gloss (G) Platinum • Champagne • Gold • Cognac • Gunmetal • Antique Brass • Pewter • Bronzed
Coat Options Satin (S) • Gloss (G)
Classic (Additional to above) Polished • Natural Steel • Brass Toned • Matte Brass Toned • Oil Rubbed • Waxed

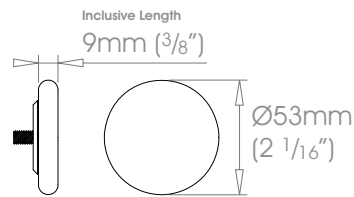

30mm (1 3/16") Not Available

! 30mm (1 3/16") available with Silent Gliss 5600 & Hand Drawn Options only

38mm (1 1/2") Classic - Stud

W Weight 159g (5.5oz)

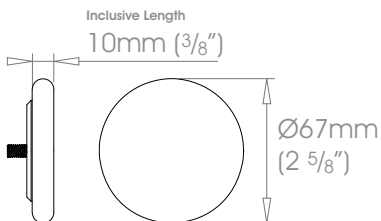

50mm (2") Classic - Stud

W Weight 286g (10oz)

ECLIPSE Finials • Classic - Large Stud

Finishes Alabaster • Dusk • Granite • Slate • Flint • Barley • Dove • Millstone • Clay • Cocoa • Cloud • Ceramic • Bone • Cream • Parchment • Damson • Moss • Smoke • Frame Grey • Raven **Coat Options** Matte (M) • Satin (S) • Gloss (G) Platinum • Champagne • Gold • Cognac • Gunmetal • Antique Brass • Pewter • Bronzed **Coat Options** Satin (S) • Gloss (G)
Classic (Additional to above) Polished • Natural Steel • Brass Toned • Matte Brass Toned • Oil Rubbed • Waxed

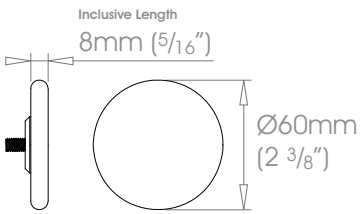

30mm (1 3/16") Classic - Large Stud

W Weight 174g (6oz)

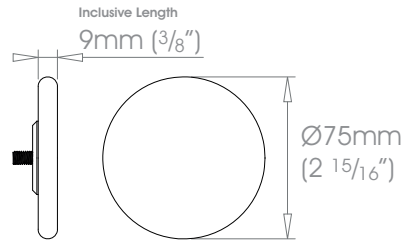

38mm (1 1/2") Classic - Large Stud

W Weight 309g (11oz)

! 30mm (1 3/16") available with Silent Gliss 5600 & Hand Drawn Options only

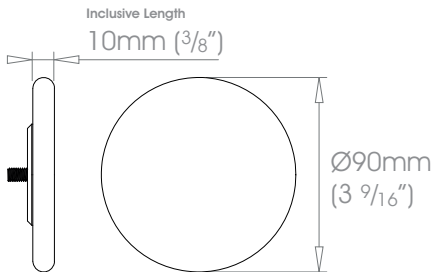

50mm (2") Classic - Large Stud

W Weight 502g (1lb 2oz)

ECLIPSE Finials • Classic - Button Stud

Finishes Alabaster • Dusk • Granite • Slate • Flint • Barley • Dove • Millstone • Clay • Cocoa • Cloud • Ceramic • Bone • Cream • Parchment • Damson • Moss • Smoke • Frame Grey • Raven **Coat Options** Matte (M) • Satin (S) • Gloss (G) Platinum • Champagne • Gold • Cognac • Gunmetal • Antique Brass • Pewter • Bronzed **Coat Options** Satin (S) • Gloss (G)
Classic (Additional to above) Polished • Natural Steel • Brass Toned • Matte Brass Toned • Oil Rubbed • Waxed

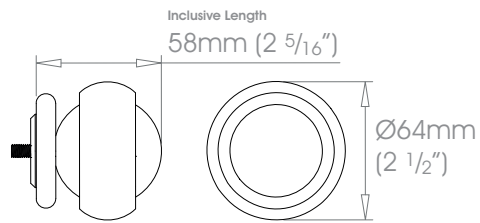

30mm (1 3/16") Not Available

! 30mm (1 3/16") available with Silent Gliss 5600 & Hand Drawn Options only

38mm (1 1/2") Classic - Button Stud

W Weight 711g (1lb 9oz)

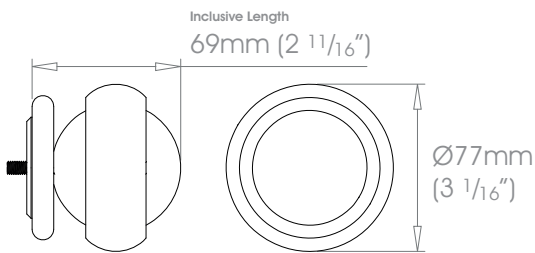

50mm (2") Classic - Button Stud

W Weight 1143g (2lb 8oz)

ECLIPSE Finials • Classic - Ball

Finishes Alabaster • Dusk • Granite • Slate • Flint • Barley • Dove • Millstone • Clay • Cocoa • Cloud • Ceramic • Bone • Cream • Parchment • Damson • Moss • Smoke • Frame Grey • Raven **Coat Options** Matte (M) • Satin (S) • Gloss (G) Platinum • Champagne • Gold • Cognac • Gunmetal • Antique Brass • Pewter • Bronzed **Coat Options** Satin (S) • Gloss (G)
Classic (Additional to above) Polished • Natural Steel • Brass Toned • Matte Brass Toned • Oil Rubbed • Waxed

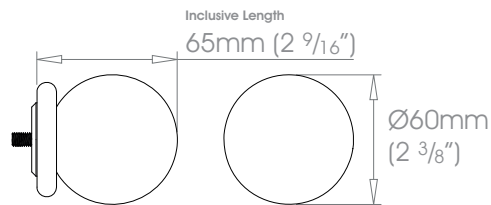

30mm (1 3/16") Not Available

! 30mm (1 3/16") available with Silent Gliss 5600 & Hand Drawn Options only

38mm (1 1/2") Classic - Ball

W Weight 386g (13.5oz)

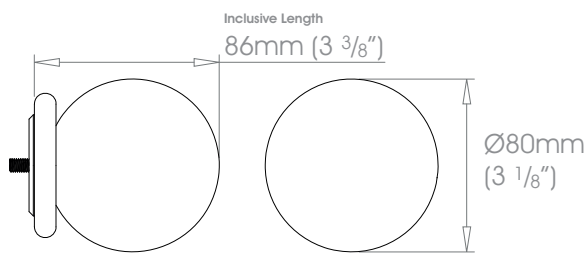

50mm (2") Classic - Ball

W Weight 703g (1lb 9oz)

FINIALS
DECO

ECLIPSE Finials • Deco - End Cap

Finishes Alabaster • Dusk • Granite • Slate • Flint • Barley • Dove • Millstone • Clay • Cocoa • Cloud • Ceramic • Bone • Cream • Parchment • Damson • Moss • Smoke • Frame Grey • Raven **Coat Options** Matte (M) • Satin (S) • Gloss (G) Platinum • Champagne • Gold • Cognac • Gunmetal • Antique Brass • Pewter • Bronzed **Coat Options** Satin (S) • Gloss (G)
Deco (Additional to above) Aged Brass* • Waxed Brass • Polished Brass* • Polished Nickel - Can be specified at twice the cost of the standard finish

The end cap can be specified free of charge.

Please note that if this option is not available on wood coverpoles

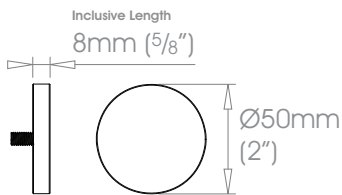

50mm (2") Deco - End Cap

W Weight 140g (5oz)

Please note that due to manufacturing process's size and shape may vary slightly to shown diagram.

* Brass finishes are supplied unlacquered & will tarnish over time a clear lacquer may be applied on request as a custom finish.

ECLIPSE Finials • Deco - Contrast Stud

Finishes Alabaster • Dusk • Granite • Slate • Flint • Barley • Dove • Millstone • Clay • Cocoa • Cloud • Ceramic • Bone • Cream • Parchment • Damson • Moss • Smoke • Frame Grey • Raven **Coat Options** Matte (M) • Satin (S) • Gloss (G) Platinum • Champagne • Gold • Cognac • Gunmetal • Antique Brass • Pewter • Bronzed **Coat Options** Satin (S) • Gloss (G)
Deco (Additional to above) Aged Brass* • Waxed Brass • Polished Brass* • Polished Nickel - Can be specified at twice the cost of the standard finish

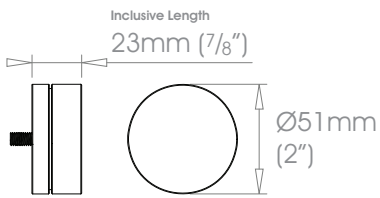

50mm (2") Deco - Contrast Stud

W Weight 386g (13oz)

Please note that due to manufacturing process's size and shape may vary slightly to shown diagram.

* Brass finishes are supplied unlacquered & will tarnish over time a clear lacquer may be applied on request as a custom finish.

ECLIPSE Finials • Deco - Wooden Contrast Stud

Finishes Alabaster • Dusk • Granite • Slate • Flint • Barley • Dove • Millstone • Clay • Cocoa • Cloud • Ceramic • Bone • Cream • Parchment • Damson • Moss • Smoke
Frame Grey • Raven **Coat Options** Matte (M) • Satin (S) • Gloss (G) • Paint on Tulip Wood (P)
Platinum • Champagne • Gold • Cognac • Gunmetal • Antique Brass • Pewter • Bronzed **Coat Options** Satin (S) • Gloss (G)
Deco (Additional to above) Aged Brass* • Waxed Brass • Polished Brass* • Polished Nickel - Can be specified at twice the cost of the standard finish
Aged Oak • Jacobean Oak • Antique Mahogany • Ebony

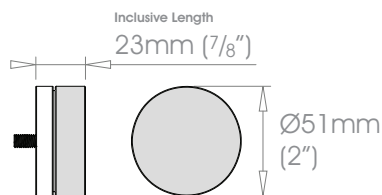

50mm (2") Deco - Wooden Contrast Stud

 Weight 386g (13oz)

Please note that due to manufacturing process's size and shape may vary slightly to shown diagram.

* Brass finishes are supplied unlacquered & will tarnish over time a clear lacquer may be applied on request as a custom finish.

ECLIPSE Finials • Deco- Flute

Finishes Alabaster • Dusk • Granite • Slate • Flint • Barley • Dove • Millstone • Clay • Cocoa • Cloud • Ceramic • Bone • Cream • Parchment • Damson • Moss • Smoke • Frame Grey • Raven **Coat Options** Matte (M) • Satin (S) • Gloss (G) Platinum • Champagne • Gold • Cognac • Gunmetal • Antique Brass • Pewter • Bronzed **Coat Options** Satin (S) • Gloss (G)
Deco (Additional to above) Aged Brass* • Waxed Brass • Polished Brass* • Polished Nickel - Can be specified at twice the cost of the standard finish

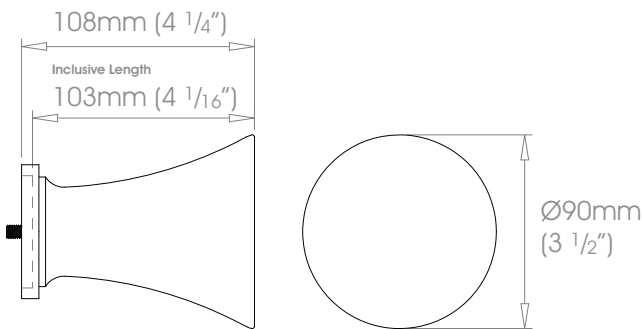

50mm (2") Deco - Flute

W Weight 632g (1lb 6oz)

Please note that due to manufacturing process's size and shape may vary slightly to shown diagram.

* Brass finishes are supplied unlacquered & will tarnish over time a clear lacquer may be applied on request as a custom finish.

ECLIPSE Finials • Deco - Squat Ball

Finishes Alabaster • Dusk • Granite • Slate • Flint • Barley • Dove • Millstone • Clay • Cocoa • Cloud • Ceramic • Bone • Cream • Parchment • Damson • Moss • Smoke • Frame Grey • Raven **Coat Options** Matte (M) • Satin (S) • Gloss (G) Platinum • Champagne • Gold • Cognac • Gunmetal • Antique Brass • Pewter • Bronzed **Coat Options** Satin (S) • Gloss (G)
Deco (Additional to above) Aged Brass* • Waxed Brass • Polished Brass* • Polished Nickel - Can be specified at twice the cost of the standard finish

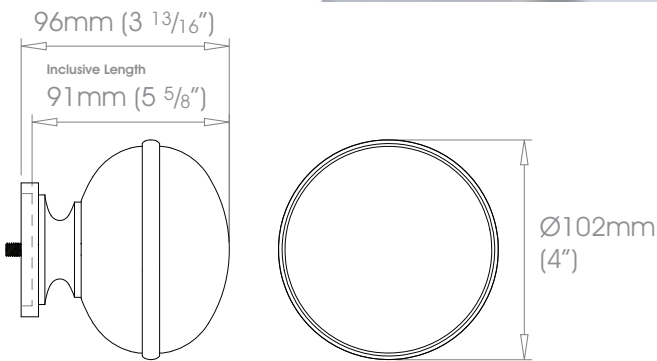
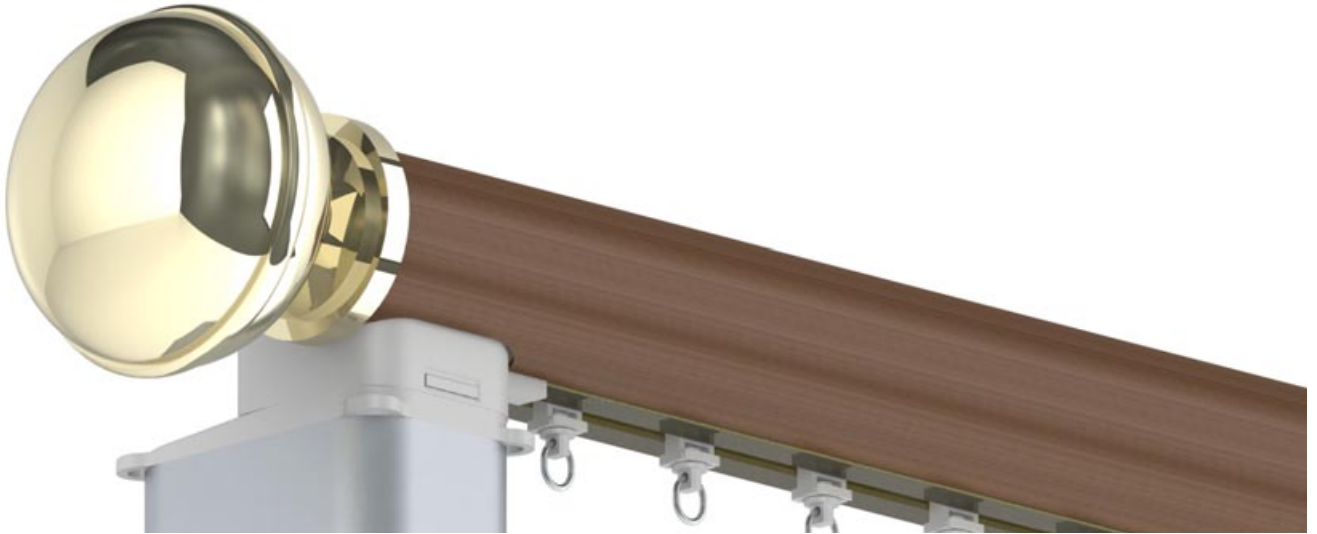

50mm (2") Deco - Squat Ball

W Weight 1kg (2lb 4oz)

Please note that due to manufacturing process's size and shape may vary slightly to shown diagram.

* Brass finishes are supplied unlacquered & will tarnish over time a clear lacquer may be applied on request as a custom finish.

ECLIPSE Finials • Deco - Wooden Squat Ball

Finishes

Alabaster • Dusk • Granite • Slate • Flint • Barley • Dove • Millstone • Clay • Cocoa • Cloud • Ceramic • Bone • Cream • Parchment • Damson • Moss • Smoke
Frame Grey • Raven **Coat Options** Matte (M) • Satin (S) • Gloss (G) • Paint on Tulip Wood (P)
Platinum • Champagne • Gold • Cognac • Gunmetal • Antique Brass • Pewter • Bronzed **Coat Options** Satin (S) • Gloss (G)
Deco (Additional to above) Aged Brass* • Waxed Brass • Polished Brass* • Polished Nickel - Can be specified at twice the cost of the standard finish
Aged Oak • Jacobean Oak • Antique Mahogany • Ebony

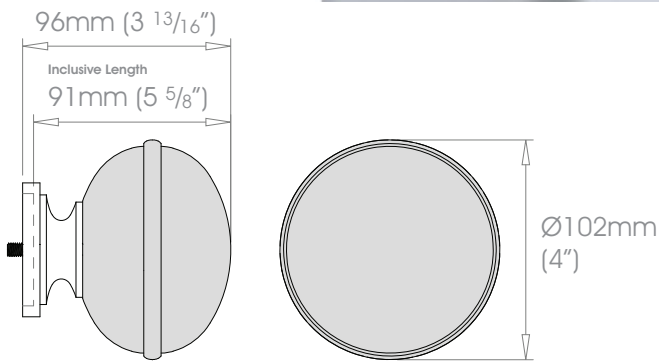

50mm (2") Deco - Wooden Squat Ball

W Weight 1kg (2lb 4oz)

Please note that due to manufacturing process's size and shape may vary slightly to shown diagram.

* Brass finishes are supplied unlacquered & will tarnish over time a clear lacquer may be applied on request as a custom finish.

ECLIPSE Finials • Deco - Templar

Finishes Alabaster • Dusk • Granite • Slate • Flint • Barley • Dove • Millstone • Clay • Cocoa • Cloud • Ceramic • Bone • Cream • Parchment • Damson • Moss • Smoke • Frame Grey • Raven **Coat Options** Matte (M) • Satin (S) • Gloss (G) Platinum • Champagne • Gold • Cognac • Gunmetal • Antique Brass • Pewter • Bronzed **Coat Options** Satin (S) • Gloss (G)
Deco (Additional to above) Aged Brass* • Waxed Brass • Polished Brass* • Polished Nickel - Can be specified at twice the cost of the standard finish

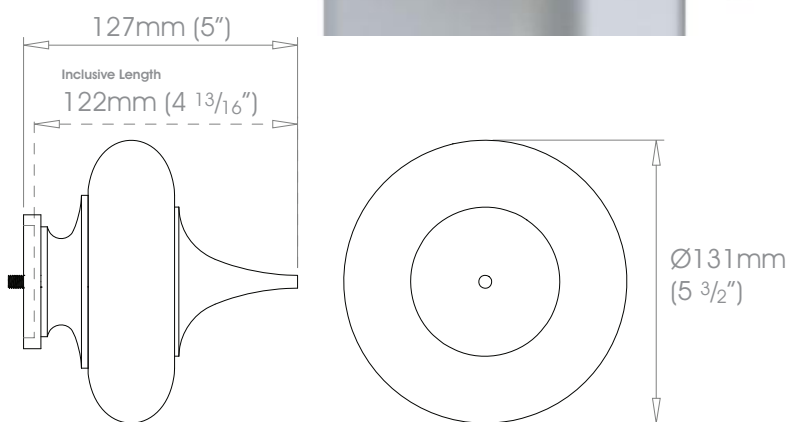

50mm (2") Deco - Templar

W Weight 1.5kg (3lb 5oz)

Please note that due to manufacturing process's size and shape may vary slightly to shown diagram.

* Brass finishes are supplied unlacquered & will tarnish over time a clear lacquer may be applied on request as a custom finish.

ECLIPSE Finials • Deco - Crystal Templar

Finishes Alabaster • Dusk • Granite • Slate • Flint • Barley • Dove • Millstone • Clay • Cocoa • Cloud • Ceramic • Bone • Cream • Parchment • Damson • Moss • Smoke • Frame Grey • Raven **Coat Options** Matte (M) • Satin (S) • Gloss (G) Platinum • Champagne • Gold • Cognac • Gunmetal • Antique Brass • Pewter • Bronzed **Coat Options** Satin (S) • Gloss (G)
Deco (Additional to above) Aged Brass* • Waxed Brass • Polished Brass* • Polished Nickel - Can be specified at twice the cost of the standard finish

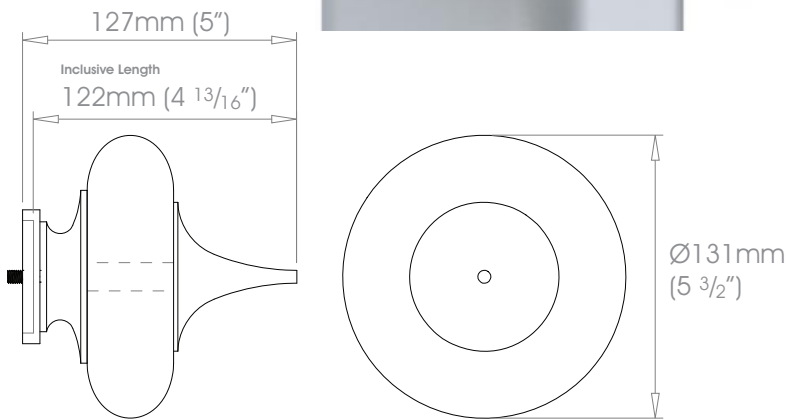
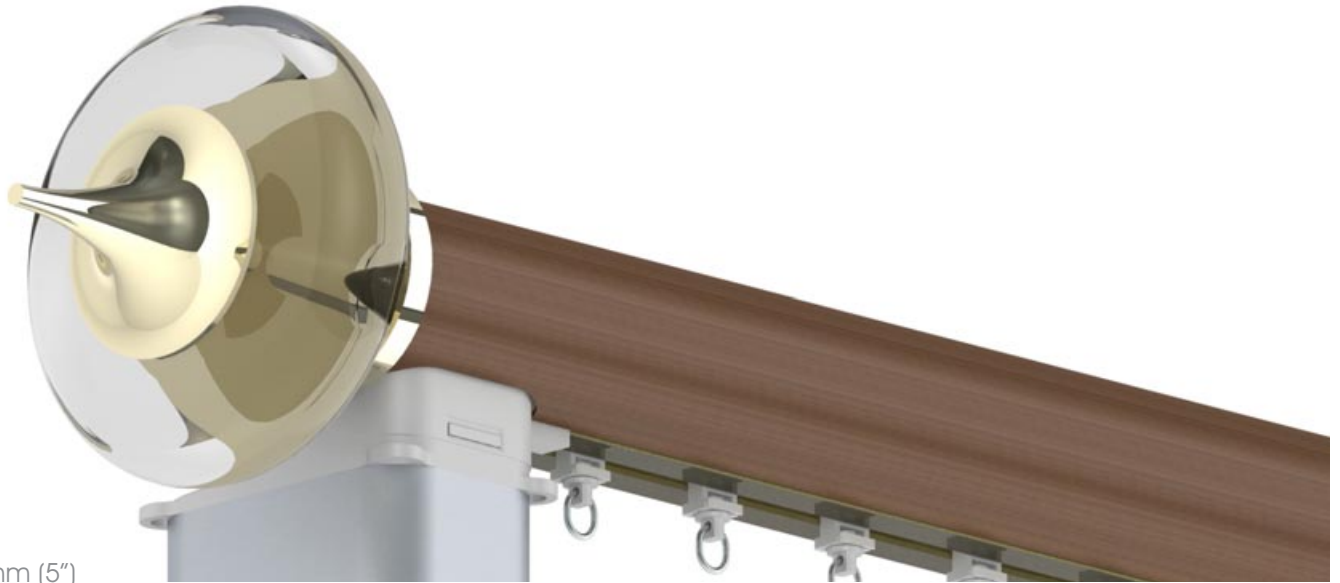

50mm (2") Deco - Crystal Templar

W Weight 2.3kg (5lb 1oz)

Please note that due to manufacturing process's size and shape may vary slightly to shown diagram.

* Brass finishes are supplied unlacquered & will tarnish over time a clear lacquer may be applied on request as a custom finish.

⚠ Crystal finials should not be positioned in direct sunlight, and are not suitable for use in conservatories

ECLIPSE Finials • Deco - Wooden Templar

Finishes Alabaster • Dusk • Granite • Slate • Flint • Barley • Dove • Millstone • Clay • Cocoa • Cloud • Ceramic • Bone • Cream • Parchment • Damson • Moss • Smoke
Frame Grey • Raven **Coat Options** Matte (M) • Satin (S) • Gloss (G) • Paint on Tulip Wood (P)
Platinum • Champagne • Gold • Cognac • Gunmetal • Antique Brass • Pewter • Bronzed **Coat Options** Satin (S) • Gloss (G)
Deco (Additional to above) Aged Brass* • Waxed Brass • Polished Brass* • Polished Nickel - Can be specified at twice the cost of the standard finish
Aged Oak • Jacobean Oak • Antique Mahogany • Ebony

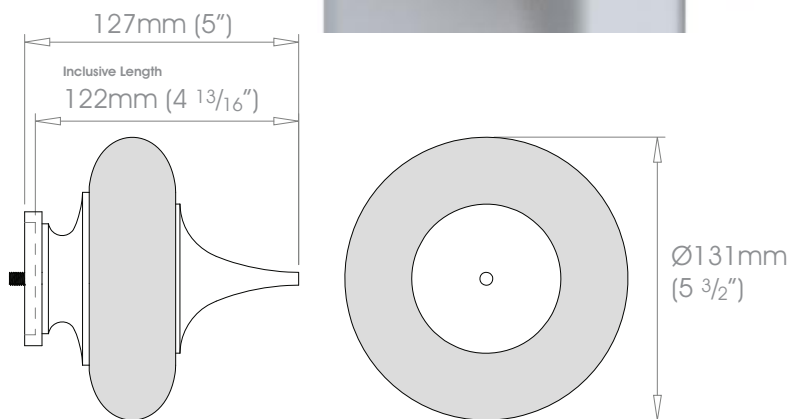

50mm (2") Deco - Wooden Templar

W Weight 1.5kg (3lb 5oz)

Please note that due to manufacturing process's size and shape may vary slightly to shown diagram.

* Brass finishes are supplied unlacquered & will tarnish over time a clear lacquer may be applied on request as a custom finish.

ECLIPSE Finials • Deco - Discus

Finishes Alabaster • Dusk • Granite • Slate • Flint • Barley • Dove • Millstone • Clay • Cocoa • Cloud • Ceramic • Bone • Cream • Parchment • Damson • Moss • Smoke • Frame Grey • Raven **Coat Options** Matte (M) • Satin (S) • Gloss (G) Platinum • Champagne • Gold • Cognac • Gunmetal • Antique Brass • Pewter • Bronzed **Coat Options** Satin (S) • Gloss (G)
Deco (Additional to above) Aged Brass* • Waxed Brass • Polished Brass* • Polished Nickel - Can be specified at twice the cost of the standard finish

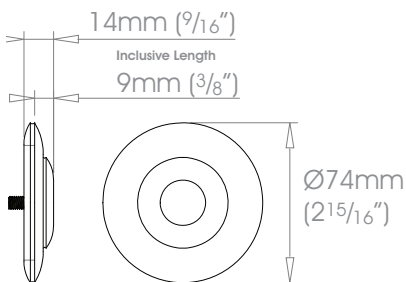

50mm (2") Deco - Discus

W Weight 260g (9oz)

Please note that due to manufacturing process's size and shape may vary slightly to shown diagram.

* Brass finishes are supplied unlacquered & will tarnish over time a clear lacquer may be applied on request as a custom finish.

ECLIPSE Finials • Deco - Ribbed Sphere

Finishes Alabaster • Dusk • Granite • Slate • Flint • Barley • Dove • Millstone • Clay • Cocoa • Cloud • Ceramic • Bone • Cream • Parchment • Damson • Moss • Smoke • Frame Grey • Raven **Coat Options** Matte (M) • Satin (S) • Gloss (G) Platinum • Champagne • Gold • Cognac • Gunmetal • Antique Brass • Pewter • Bronzed **Coat Options** Satin (S) • Gloss (G)
Deco (Additional to above) Aged Brass* • Waxed Brass • Polished Brass* • Polished Nickel - Can be specified at twice the cost of the standard finish

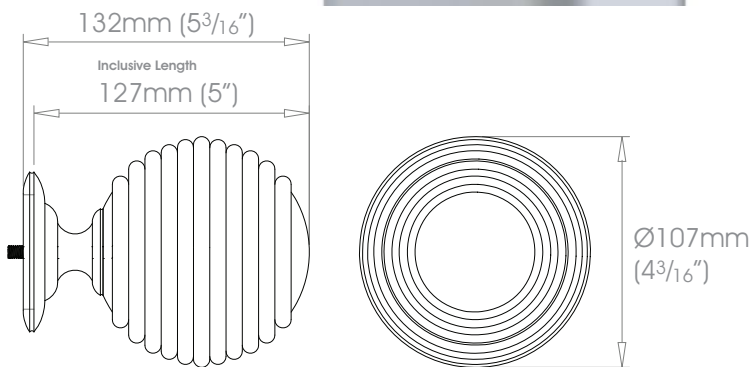

50mm (2") Deco - Ribbed Sphere

W Weight 1.2kg (2lb 8oz)

Please note that due to manufacturing process's size and shape may vary slightly to shown diagram.

* Brass finishes are supplied unlacquered & will tarnish over time a clear lacquer may be applied on request as a custom finish.

ECLIPSE Finials • Deco - Wooden Ribbed Sphere

Finishes

Alabaster • Dusk • Granite • Slate • Flint • Barley • Dove • Millstone • Clay • Cocoa • Cloud • Ceramic • Bone • Cream • Parchment • Damson • Moss • Smoke
Frame Grey • Raven **Coat Options** Matte (M) • Satin (S) • Gloss (G) • Paint on Tulip Wood (P)
Platinum • Champagne • Gold • Cognac • Gunmetal • Antique Brass • Pewter • Bronzed **Coat Options** Satin (S) • Gloss (G)
Deco (Additional to above) Aged Brass* • Waxed Brass • Polished Brass* • Polished Nickel - Can be specified at twice the cost of the standard finish
Aged Oak • Jacobean Oak • Antique Mahogany • Ebony

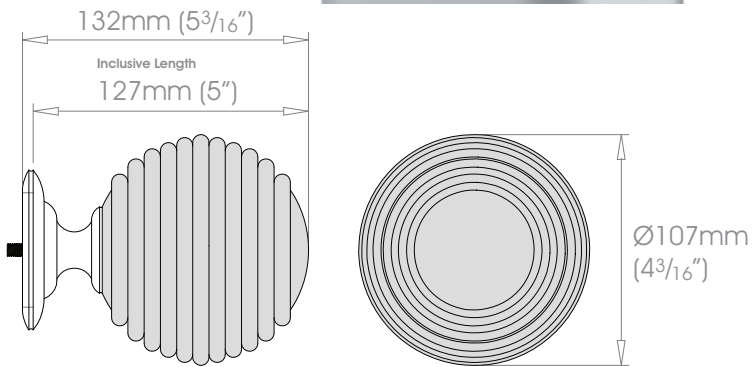

50mm (2") Deco - Wood Ribbed Sphere

 Weight 1.2kg (2lb 8oz)

Please note that due to manufacturing process's size and shape may vary slightly to shown diagram.

* Brass finishes are supplied unlacquered & will tarnish over time a clear lacquer may be applied on request as a custom finish.

BRACKETS

ECLIPSE Brackets

Bradley offers a wide selection of brackets to fit most installations. The main categories are side, mid, ceiling, double and recess brackets. If the standard brackets will not work, custom brackets are available.

Side Brackets

Are available in both single pole and double pole configurations. They are usually mounted towards the ends of pole for greater support. They have a vertical back plate that allows for the greatest fixing area.

Mid and Joining brackets

Are used in the mid points of the system. A bracket is always required when poles are being joined. Mid brackets have a smaller horizontal back plate that provide support while also allowing clearance for window elements like moulding.

Intermediate Support Clamps

Intermediate support clamps are designed to support between brackets. Keeping the coverpole and track together. An intermediate support clamp may be required when the drapes are opened and are stacked at the ends of the system to help support the weight of the fabric.

Projection

Is the distance from the back of the wall to the center of the pole. This measurement roughly denotes the distance from the wall that the curtain will drop. It is important when calculating wall clearance and wall stacking.

Fixing Plate Size

Is the size of the back plate when mounted on the wall. It is used to compute any possible clearance issues.

Custom Brackets

Are available, ranging from simple projection changes. To completely a original design. Due to our in-house design and manufacturing capabilities, we can do customs in volumes as little as 1 unit. All special projection brackets are charged at twice the cost of their standard projection equivalent. Brackets over 200mm (8") projection or that require a change to their backplate or an uplift/downlift of pole centre also attract special design charge per design drawing. Most custom brackets can be delivered within a 4 week lead-time. Please contact us for any custom bracket requests.

ECLIPSE Brackets • Single Bracket - Side

Finishes

Alabaster • Dusk • Granite • Slate • Flint • Barley • Dove • Millstone • Clay • Cocoa • Cloud • Ceramic • Bone • Cream • Parchment • Damson • Moss • Smoke • Frame Grey • Raven **Coat Options** Matte (M) • Satin (S) • Gloss (G) Platinum • Champagne • Gold • Cognac • Gunmetal • Antique Brass • Pewter • Bronzed **Coat Options** Satin (S) • Gloss (G)

Progressive (Additional to above) Brushed Stainless • Brushed Brass Tint • Brushed Bronze Tint • Brushed Carbon Tint

Classic (Additional to above) Polished • Natural Steel • Brass Toned • Matte Brass Toned • Oil Rubbed • Waxed

Deco (Additional to above) Aged Brass* • Waxed Brass* • Polished Brass* • Polished Nickel - Can be specified at twice the cost of the standard finish

* Will be finished in a complementary finish and supplied with a matching self colour coverplate. Please note coverplate will add 4mm to the height & width of the bracket



Please note brackets will be supplied with the relevant track fixing, which may differ to those shown in the diagrams

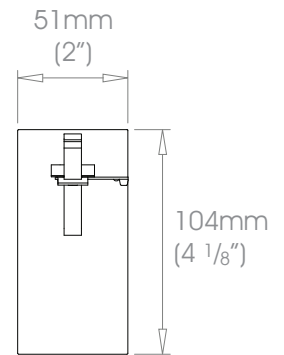
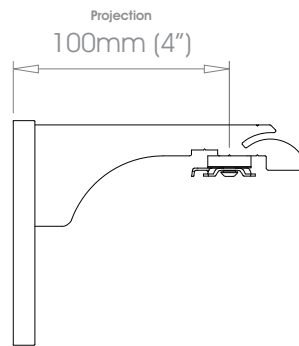

30mm (1 3/16") Not Available

! 30mm (1 3/16") available with Silent Gliss 5600 & Hand Drawn Options only

38mm (1 1/2") Single Bracket - Side

Projection 100mm (4")

Weight 422g (15oz)

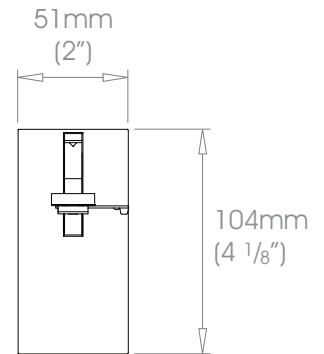
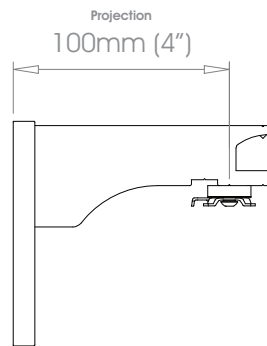
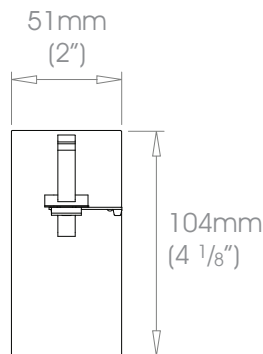
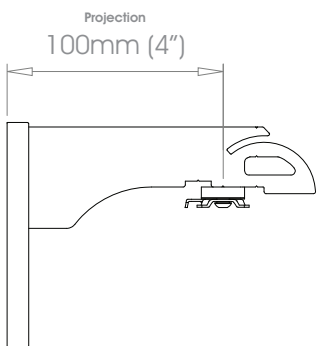

50mm (2") Single Bracket - Side

Projection 100mm (4")

Weight 500g (11lb 2oz)

Wood 50mm (2") Single Bracket - Side

Projection 100mm (4")

Weight 500g (11lb 2oz)

ECLIPSE Brackets • Single Bracket - Mid

Finishes

Alabaster • Dusk • Granite • Slate • Flint • Barley • Dove • Millstone • Clay • Cocoa • Cloud • Ceramic • Bone • Cream • Parchment • Damson • Moss • Smoke • Frame Grey • Raven
Coat Options Matte (M) • Satin (S) • Gloss (G) • Platinum • Champagne • Gold • Cognac • Gunmetal • Antique Brass • Pewter • Bronzed
Coat Options Satin (S) • Gloss (G)

Progressive (Additional to above) Brushed Stainless • Brushed Brass Tint • Brushed Bronze Tint • Brushed Carbon Tint

Classic (Additional to above) Polished • Natural Steel • Brass Toned • Matte Brass Toned • Oil Rubbed • Waxed

Deco (Additional to above) Aged Brass* • Waxed Brass* • Polished Brass* • Polished Nickel - Can be specified at twice the cost of the standard finish

* Will be finished in a complementary finish and supplied with a matching self colour coverplate. Please note coverplate will add 4mm to the height & width of the bracket

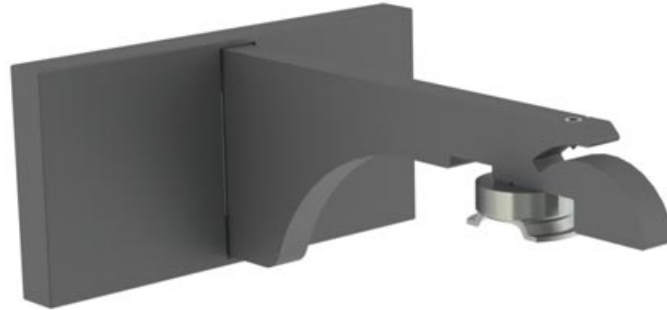

Please note brackets will be supplied with the relevant track fixing, which may differ to those shown in the diagrams

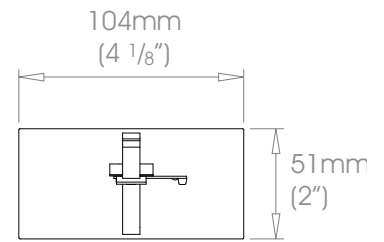
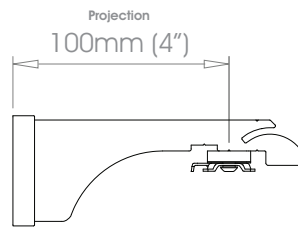

30mm (1 3/16") Not Available

! 30mm (1 3/16") available with Silent Gliss 5600 & Hand Drawn Options only

38mm (1 1/2") Single Bracket - Mid

Projection 100mm (4")

Weight 422g (15oz)

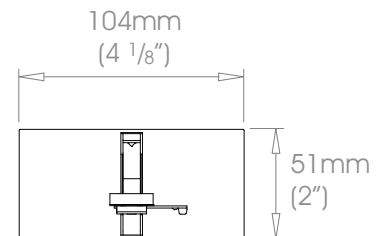
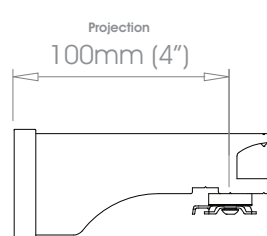
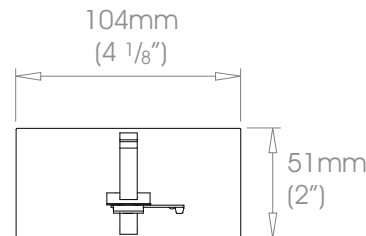
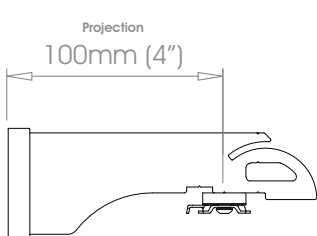

50mm (2") Single Bracket - Mid

Projection 100mm (4")

Weight 500g (11lb 2oz)

50mm (2") Single Bracket - Mid

Projection 100mm (4")

Weight 500g (11lb 2oz)

ECLIPSE Brackets • Single Bracket - Joining

Finishes

Alabaster • Dusk • Granite • Slate • Flint • Barley • Dove • Millstone • Clay • Cocoa • Cloud • Ceramic • Bone • Cream • Parchment • Damson • Moss • Smoke • Frame Grey • Raven **Coat Options** Matte (M) • Satin (S) • Gloss (G) Platinum • Champagne • Gold • Cognac • Gunmetal • Antique Brass • Pewter • Bronzed **Coat Options** Satin (S) • Gloss (G)

Progressive (Additional to above) Brushed Stainless • Brushed Brass Tint • Brushed Bronze Tint • Brushed Carbon Tint

Classic (Additional to above) Polished • Natural Steel • Brass Toned • Matte Brass Toned • Oil Rubbed • Waxed

Deco (Additional to above) Aged Brass* • Waxed Brass* • Polished Brass* • Polished Nickel - Can be specified at twice the cost of the standard finish

* Will be finished in a complementary finish and supplied with a matching self colour coverplate. Please note coverplate will add 4mm to the height & width of the bracket



Please note brackets will be supplied with the relevant track fixing, which may differ to those shown in the diagrams

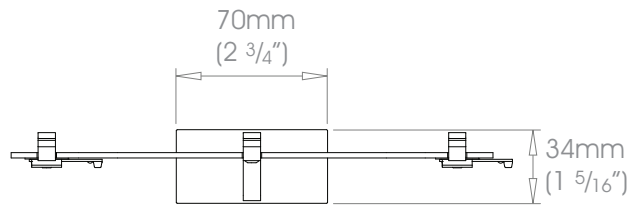
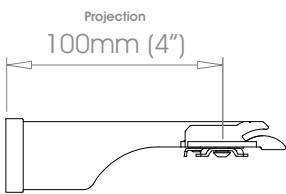

30mm (1 3/16") Not Available



30mm (1 3/16") available with Silent Gliss 5600 & Hand Drawn Options only

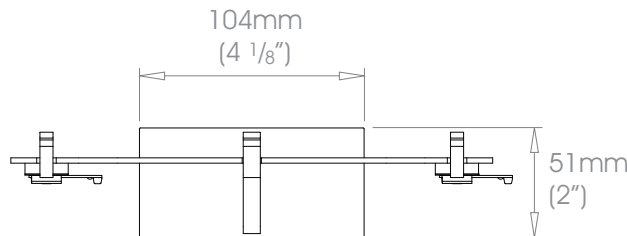
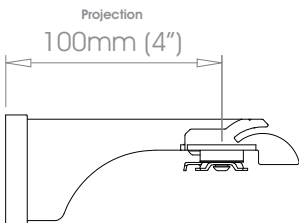

38mm (1 1/2") Single Bracket - Joining

 Projection 100mm (4")

 Weight 547g (1lb 4oz)

ECLIPSE Brackets • Single Bracket - Joining

Finishes

Alabaster • Dusk • Granite • Slate • Flint • Barley • Dove • Millstone • Clay • Cocoa • Cloud • Ceramic • Bone • Cream • Parchment • Damson • Moss • Smoke • Frame Grey • Raven
Coat Options Matte (M) • Satin (S) • Gloss (G) • Platinum • Champagne • Gold • Cognac • Gunmetal • Antique Brass • Pewter • Bronzed
Coat Options Satin (S) • Gloss (G)
Progressive (Additional to above) Brushed Stainless • Brushed Brass Tint • Brushed Bronze Tint • Brushed Carbon Tint
Classic (Additional to above) Polished • Natural Steel • Brass Toned • Matte Brass Toned • Oil Rubbed • Waxed
Deco (Additional to above) Aged Brass* • Waxed Brass* • Polished Brass* • Polished Nickel - Can be specified at twice the cost of the standard finish
* Will be finished in a complementary finish and supplied with a matching self colour coverplate. Please note coverplate will add 4mm to the height & width of the bracket



Please note brackets will be supplied with the relevant track fixing, which may differ to those shown in the diagrams

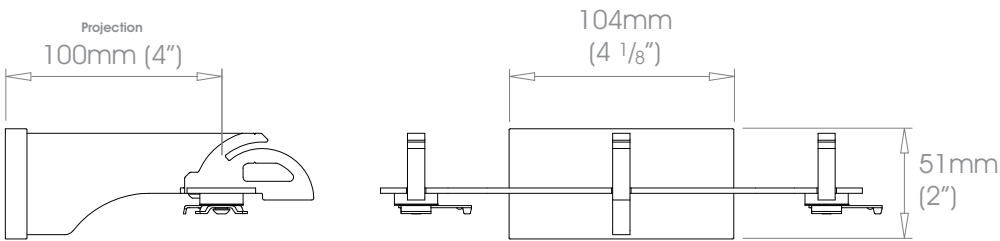

50mm (2") Single Bracket - Joining

 Projection 100mm (4")

 Weight 688g (1lb 8oz)

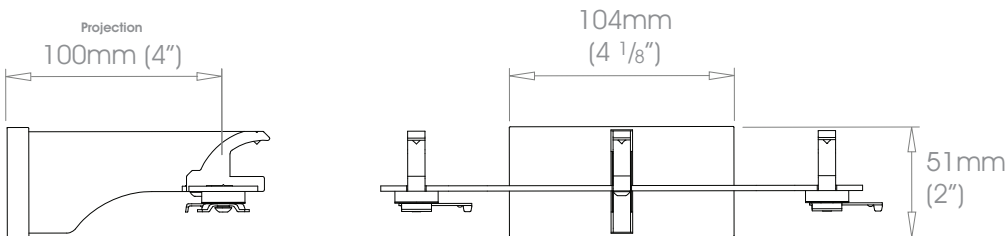

Wood 50mm (2") Single Bracket - Joining

 Projection 100mm (4")

 Weight 688g (1lb 8oz)

ECLIPSE Brackets • Ceiling Bracket - Flush

Finishes

Alabaster • Dusk • Granite • Slate • Flint • Barley • Dove • Millstone • Clay • Cocoa • Cloud • Ceramic • Bone • Cream • Parchment • Damson • Moss • Smoke • Frame Grey • Raven **Coat Options** Matte (M) • Satin (S) • Gloss (G) • Platinum • Champagne • Gold • Cognac • Gunmetal • Antique Brass • Pewter • Bronzed **Coat Options** Satin (S) • Gloss (G)

Progressive (Additional to above) Brushed Stainless • Brushed Brass Tint • Brushed Bronze Tint • Brushed Carbon Tint

Classic (Additional to above) Polished • Natural Steel • Brass Toned • Matte Brass Toned • Oil Rubbed • Waxed

Deco (Additional to above) Aged Brass* • Waxed Brass* • Polished Brass* • Polished Nickel - Can be specified at twice the cost of the standard finish

* Will be finished in a complementary finish

Please note brackets will be supplied with the relevant track fixing, which may differ to those shown in the diagrams



34mm
(1 5/16")

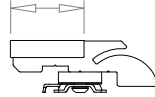

70mm
(2 3/4")

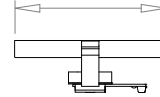

30mm (1 3/16") Not Available



30mm (1 3/16") available with Silent Gliss 5600 & Hand Drawn Options only

38mm (1 1/2") Ceiling Bracket - Flush

Weight 116g (4oz)

34mm
(1 5/16")

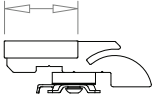

70mm
(2 3/4")

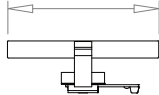

34mm
(1 5/16")

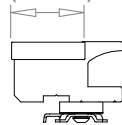

70mm
(2 3/4")

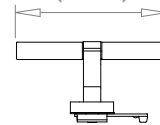

50mm (2") Ceiling Bracket - Flush

Weight 160g (6oz)

Wood 50mm (2") Ceiling Bracket - Flush

Weight 160g (6oz)

ECLIPSE Brackets • Ceiling Bracket - Flush Joining

Finishes

Alabaster • Dusk • Granite • Slate • Flint • Barley • Dove • Millstone • Clay • Cocoa • Cloud • Ceramic • Bone • Cream • Parchment • Damson • Moss • Smoke • Frame Grey • Raven **Coat Options** Matte (M) • Satin (S) • Gloss (G) • Platinum • Champagne • Gold • Cognac • Gunmetal • Antique Brass • Pewter • Bronzed **Coat Options** Satin (S) • Gloss (G)

Progressive (Additional to above) Brushed Stainless • Brushed Brass Tint • Brushed Bronze Tint • Brushed Carbon Tint

Classic (Additional to above) Polished • Natural Steel • Brass Toned • Matte Brass Toned • Oil Rubbed • Waxed

Deco (Additional to above) Aged Brass* • Waxed Brass* • Polished Brass* • Polished Nickel - Can be specified at twice the cost of the standard finish

* Will be finished in a complementary finish



Please note brackets will be supplied with the relevant track fixing, which may differ to those shown in the diagrams

34mm
(1 5/16")

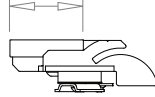

70mm
(2 3/4")

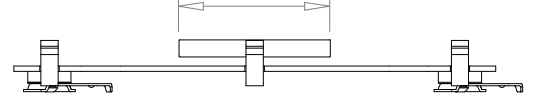

30mm (1 3/16") Not Available



30mm (1 3/16") available with Silent Gliss 5600 & Hand Drawn Options only

38mm (1 1/2") Ceiling Bracket - Flush Joining

W Weight 258g (9oz)

34mm
(1 5/16")

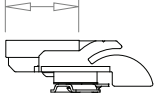

70mm
(2 3/4")

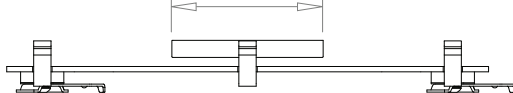

34mm
(1 5/16")

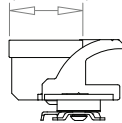

70mm
(2 3/4")

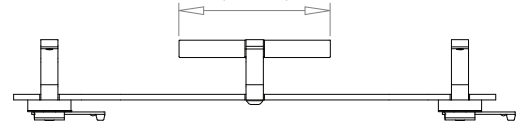

50mm (2") Ceiling Bracket - Flush Joining

W Weight 351g (13oz)

Wood 50mm (2") Ceiling Bracket - Flush Joining

W Weight 351g (13oz)

ECLIPSE Brackets • Double Bracket - Side

Finishes

Alabaster • Dusk • Granite • Slate • Flint • Barley • Dove • Millstone • Clay • Cocoa • Cloud • Ceramic • Bone • Cream • Parchment • Damson • Moss • Smoke • Frame Grey • Raven
Coat Options Matte (M) • Satin (S) • Gloss (G) Platinum • Champagne • Gold • Cognac • Gunmetal • Antique Brass • Pewter • Bronzed
Coat Options Satin (S) • Gloss (G)

Progressive (Additional to above) Brushed Stainless • Brushed Brass Tint • Brushed Bronze Tint • Brushed Carbon Tint

Classic (Additional to above) Polished • Natural Steel • Brass Toned • Matte Brass Toned • Oil Rubbed • Waxed

Deco (Additional to above) Aged Brass* • Waxed Brass* • Polished Brass* • Polished Nickel - Can be specified at twice the cost of the standard finish

* Will be finished in a complementary finish and supplied with a matching self colour coverplate. Please note coverplate will add 4mm to the height & width of the bracket



Please note brackets will be supplied with the relevant track fixing, which may differ to those shown in the diagrams

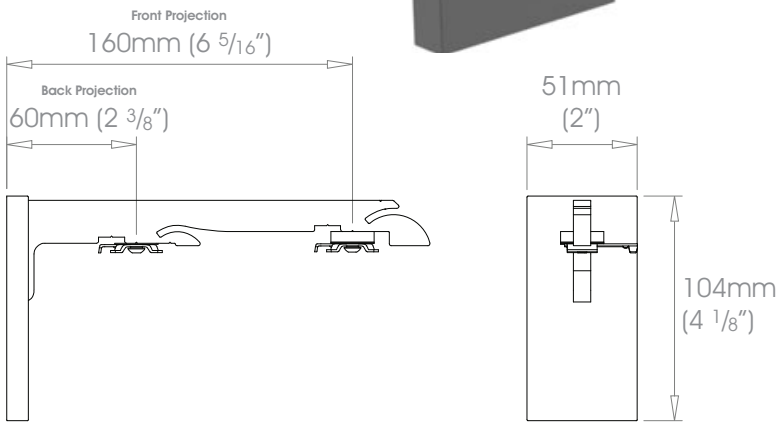

ƒ38mm (1 1/2") ƒ30mm (1 3/16") Double Bracket - Side

 Weight 456g (1lb 1oz)

! 30mm (1 3/16") available with Silent Gliss 5600 & Hand Drawn Options only

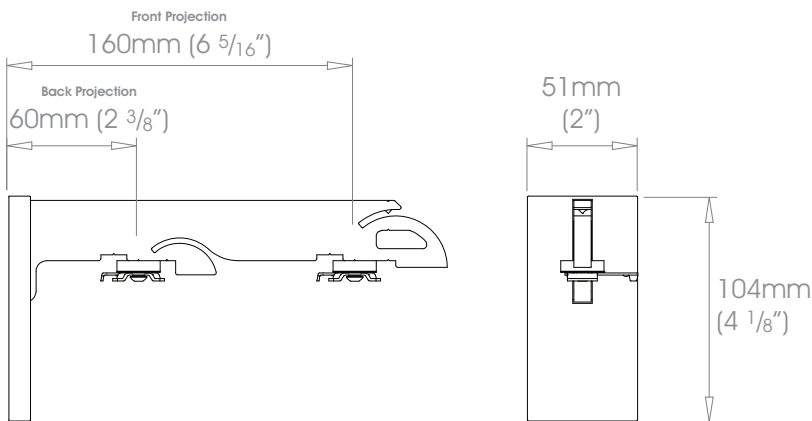

ƒ50mm (2") ƒ38mm (1 1/2") Double Bracket - Side

 Weight 583g (1lb 5oz)

ECLIPSE Brackets • Double Bracket - Mid

Finishes

Alabaster • Dusk • Granite • Slate • Flint • Barley • Dove • Millstone • Clay • Cocoa • Cloud • Ceramic • Bone • Cream • Parchment • Damson • Moss • Smoke • Frame Grey • Raven
Coat Options Matte (M) • Satin (S) • Gloss (G) • Platinum • Champagne • Gold • Cognac • Gunmetal • Antique Brass • Pewter • Bronzed
Coat Options Satin (S) • Gloss (G)

Progressive (Additional to above) Brushed Stainless • Brushed Brass Tint • Brushed Bronze Tint • Brushed Carbon Tint

Classic (Additional to above) Polished • Natural Steel • Brass Toned • Matte Brass Toned • Oil Rubbed • Waxed

Deco (Additional to above) Aged Brass* • Waxed Brass* • Polished Brass* • Polished Nickel - Can be specified at twice the cost of the standard finish

* Will be finished in a complementary finish and supplied with a matching self colour coverplate. Please note coverplate will add 4mm to the height & width of the bracket

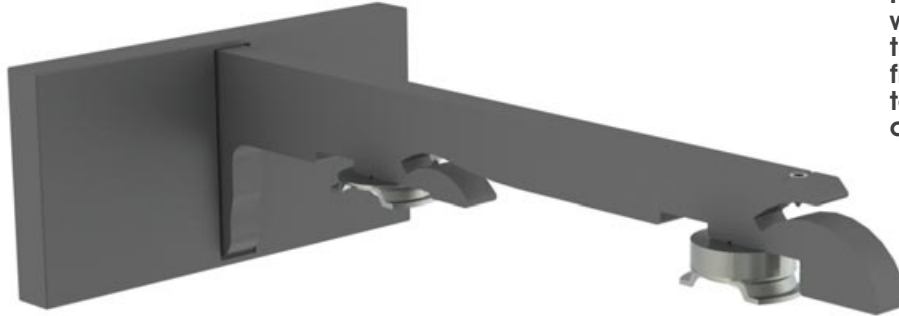

Please note brackets will be supplied with the relevant track fixing, which may differ to those shown in the diagrams

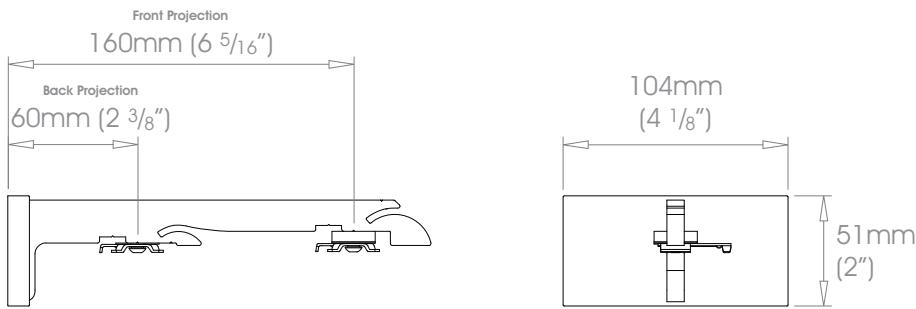

f38mm (1 1/2") b30mm (1 3/16") Double Bracket - Mid

W Weight 456g (1lb 1oz)

! 30mm (1 3/16") available with Silent Gliss 5600 & Hand Drawn Options only

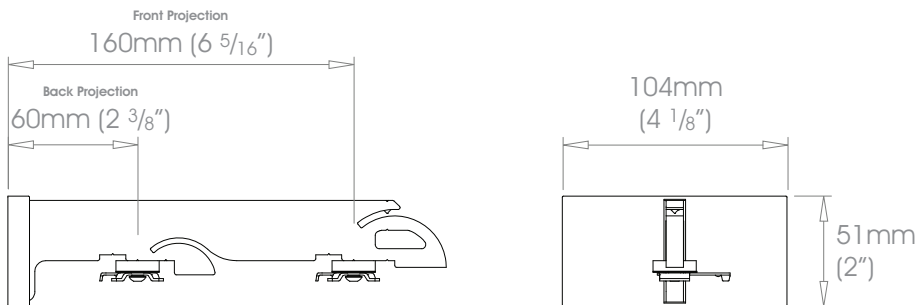

f50mm (2") b38mm (1 1/2") Double Bracket - Mid

W Weight 583g (1lb 5oz)

ECLIPSE Brackets • Double Bracket - Joining

Finishes

Alabaster • Dusk • Granite • Slate • Flint • Barley • Dove • Millstone • Clay • Cocoa • Cloud • Ceramic • Bone • Cream • Parchment • Damson • Moss • Smoke • Frame Grey • Raven
Coat Options Matte (M) • Satin (S) • Gloss (G) • Platinum • Champagne • Gold • Cognac • Gunmetal • Antique Brass • Pewter • Bronzed
Coat Options Satin (S) • Gloss (G)

Progressive (Additional to above) Brushed Stainless • Brushed Brass Tint • Brushed Bronze Tint • Brushed Carbon Tint

Classic (Additional to above) Polished • Natural Steel • Brass Toned • Matte Brass Toned • Oil Rubbed • Waxed

Deco (Additional to above) Aged Brass* • Waxed Brass* • Polished Brass* • Polished Nickel - Can be specified at twice the cost of the standard finish

* Will be finished in a complementary finish and supplied with a matching self colour coverplate. Please note coverplate will add 4mm to the height & width of the bracket

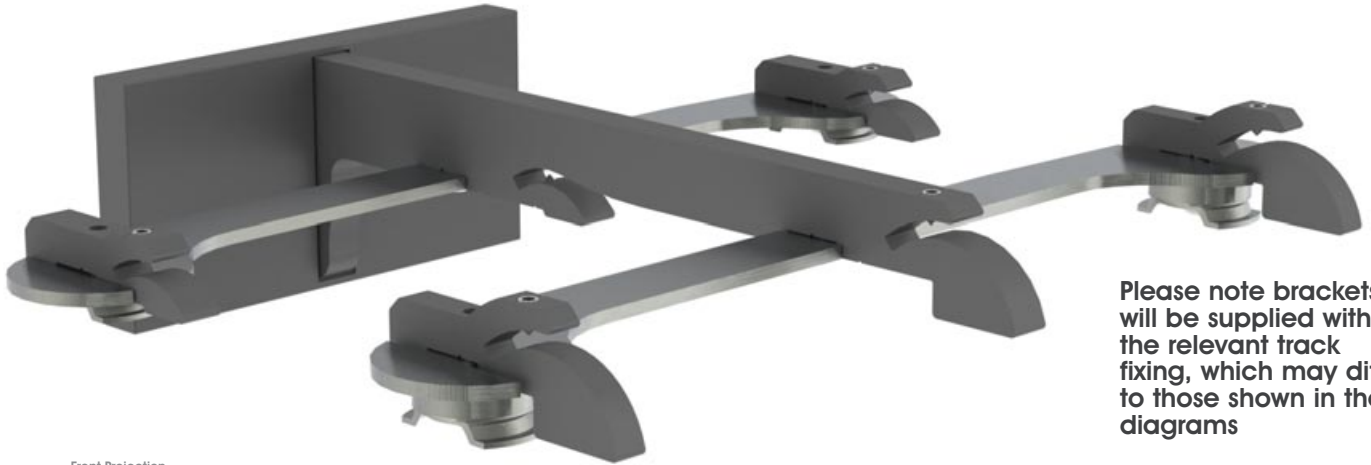

Please note brackets will be supplied with the relevant track fixing, which may differ to those shown in the diagrams

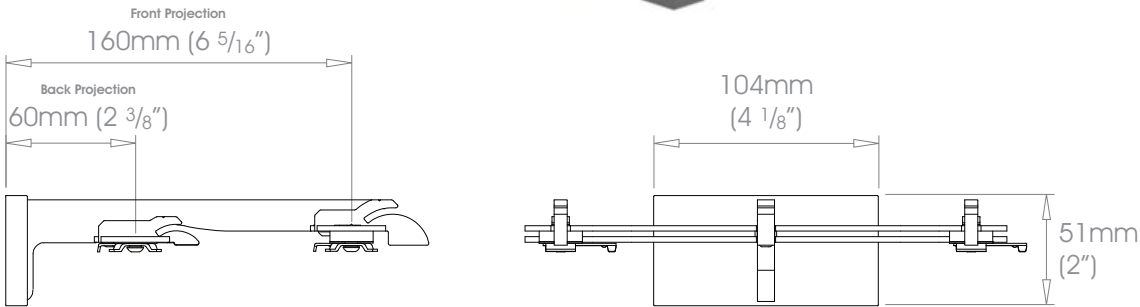

f38mm (1 1/2") b30mm (1 3/16") Double Bracket - Joining

W Weight 683g (1lb 8oz)

! 30mm (1 3/16") available with Silent Gliss 5600 & Hand Drawn Options only

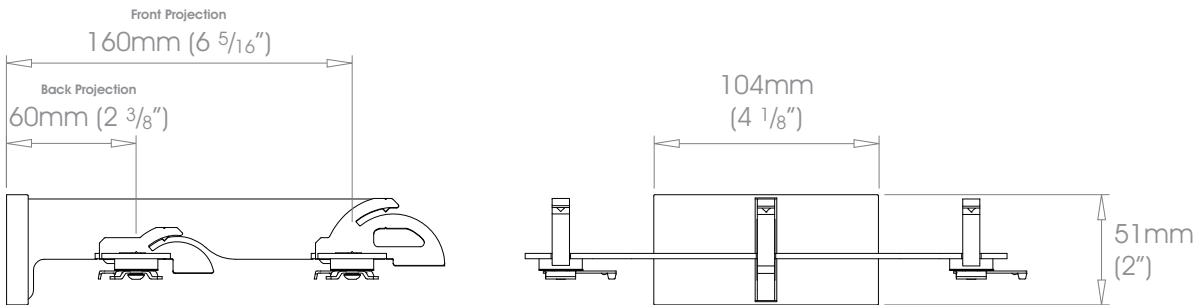

f50mm (2") b38mm (1 1/2") Double Bracket - Joining

W Weight 936g (2lb 1oz)

ECLIPSE Brackets • Intermediate Support Clamp

Finishes

Alabaster • Dusk • Granite • Slate • Flint • Barley • Dove • Millstone • Clay • Cocoa • Cloud • Ceramic • Bone • Cream • Parchment • Damson • Moss • Smoke • Frame Grey • Raven
Coat Options Matte (M) • Satin (S) • Gloss (G) • Platinum • Champagne • Gold • Cognac • Gunmetal • Antique Brass • Pewter • Bronzed
Coat Options Satin (S) • Gloss (G)
Progressive (Additional to above) Brushed Stainless • Brushed Brass Tint • Brushed Bronze Tint • Brushed Carbon Tint
Classic (Additional to above) Polished • Natural Steel • Brass Toned • Matte Brass Toned • Oil Rubbed • Waxed
Deco (Additional to above) Aged Brass • Waxed Brass • Polished Brass • Polished Nickel - Can be specified at twice the cost of the standard finish

Please note brackets will be supplied with the relevant track fixing, which may differ to those shown in the diagrams

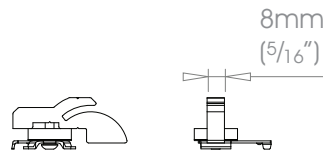

30mm (1 3/16") Not Available

! 30mm (1 3/16") available with Silent Gliss 5600 & Hand Drawn Options only

38mm (1 1/2") Intermediate Support Clamp

W Weight 35g (1oz)

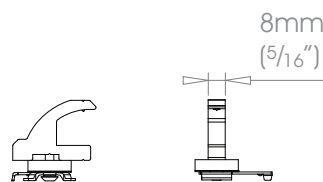
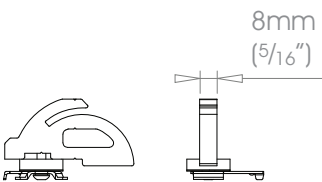

50mm (2") Intermediate Support Clamp

W Weight 59g (2oz)

Wood 50mm (2") Intermediate Support Clamp

W Weight 35g (1oz)

SOMFY®

ECLIPSE Coverpole & Electric - Somfy Track Information

Coverpole & Internal Track Relationship

Eclipse is made up of a decorative coverpole which can either be manufactured in steel, stainless steel. With a concealed smooth running aluminium track sitting behind it. The diagrams below shows the relationship between the two components

Available pole diameter's - $\varnothing 38\text{mm}$ (1 1/2") • 50mm (2")

The overall pole cost is rounded up in 300mm (1ft) increments.

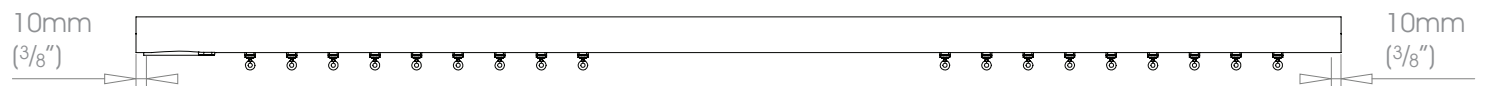

Diameter	Depth A	Depth B
$\varnothing 38\text{mm}$ (1 1/2")	54mm (2 1/8")	65mm (2 9/16")
$\varnothing 50\text{mm}$ (2")	60mm (2 3/8")	71mm (2 13/16")

! Over collar finials from Simple, Stainless & Elysian collections can be supplied on request. Please note it will reduce the overall track length shown above, by an additional 21mm (13/16")

Providing Pole Lengths

Pole lengths can be specified in two ways, Option A is our preferred method. This covers pole length only, the second option combines pole and finial lengths

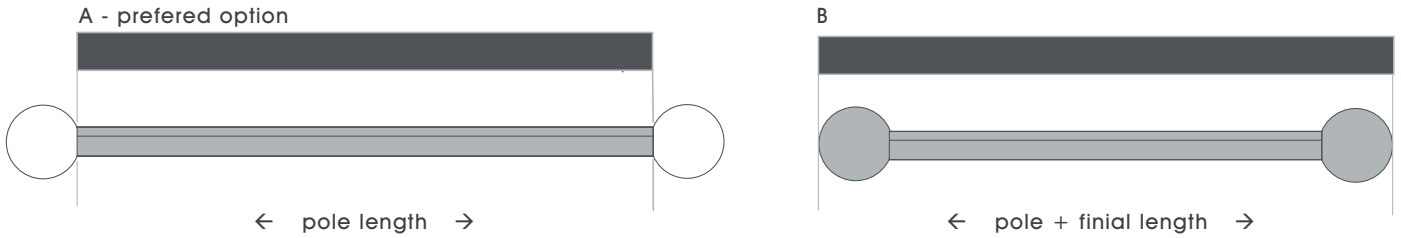

Poles are cut, bent and curved to suit individual requirements.

When calculating the length of your pole, remember to allow tolerance beyond the width of the frame for the curtains to draw back to the edge of the window.

Maximum pole length in one piece 2.9m (114").

Poles exceeding the recommended maximum distance between brackets, will be cut into equal parts unless otherwise specified. Pole joiners will be supplied. Joining brackets should be placed at every join.

Motor Type	Maximum System Length - Single Stack →	Maximum System Length - Pair Stack →←	Maximum Coverpole Section Length	Maximum Track Section Length	Bracket Spacing
Glydea 60 WT RTS	12000mm (39')	12000mm (39')	2900mm (9'6")	3000mm (10')	1500mm (5')
Irismo 45 WF RTS	10000mm (32.5')	10000mm (32.5')	2900mm (9'6")	3000mm (10')	1500mm (5')

Joining Poles

Where ever there is a join in the coverpole, this must always be supported by a joining bracket. Two clamps sit on top of the bracket to support the coverpole, a joiner sits under the bracket and slides into the top channel of the track. to keep the two parts securely together



Intermediate support clamps

Intermediate support clamps are designed to support between brackets. keeping the coverpole and track together.

A intermediate support clamp may be required when the drapes are opened and are stacked at the ends of the system



ECLIPSE Coverpole & Electric - Somfy Track Information

Electric curtain poles

Eclipse consists of a decorative coverpole and finial concealing a functional track system, with the assembly clamped together by clever bracket design.

Coverpoles over 2.9m (9'6") in length will be supplied in multiple sections, tracks over 2.9m (9'6") will be supplied in multiple sections Z folded and pre-assembled with drive belt and rollers ready for connecting and installing.

Select cover pole

Available cover pole diameter's - $\varnothing 38\text{mm}$ (1½") • 50mm (2")



Add motorised track

Can be used in a cover pole for double configurations a second track can be specified to fit behind the cover pole

Add a motor



Select Glider/Roller Option

Select from rollers or Ripple rollers



Configuration

A looped driving belt runs around the motor and along the pole. This is attached to the pilot header which in turn is attached to the lead roller. The motor operates in both directions, thereby opening and closing curtains.

Single stack

On single stack systems the motor is always positioned on the stacking side, allowing the motor to be hidden behind the curtain.



Double Stack

Double stack curtains can have the motor positioned at either end of the pole.



ECLIPSE Electric - Somfy® • Track Configuration Options

Motor Positioning

Points to consider when planning your installation, the motor needs to be positioned on same side of the window as the power supply.

Motorised systems are unsuitable for use outdoors or in damp environments such as shower rooms and bathrooms.

Somfy® Glydea Ultra / Movelite

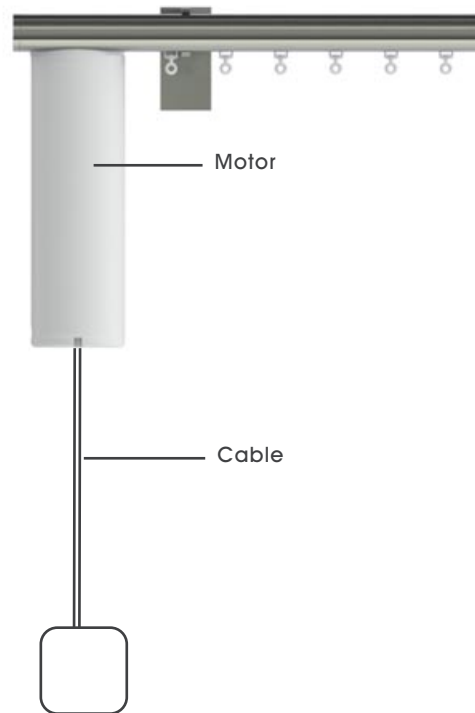

Somfy® Irismo

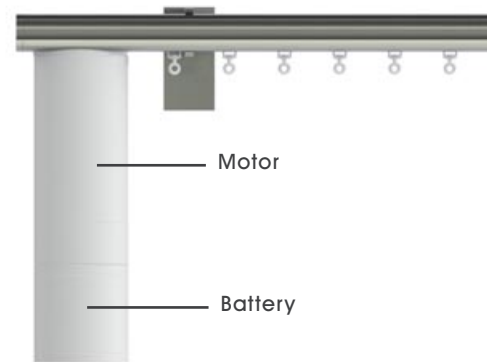

Left Hand Motor



Right Hand Motor



ECLIPSE Electric - Somfy • Configurations - Rollers

Eclipse ordered with Standard Rollers will be supplied as per the diagrams below.



Electric - Somfy - Single Stack →

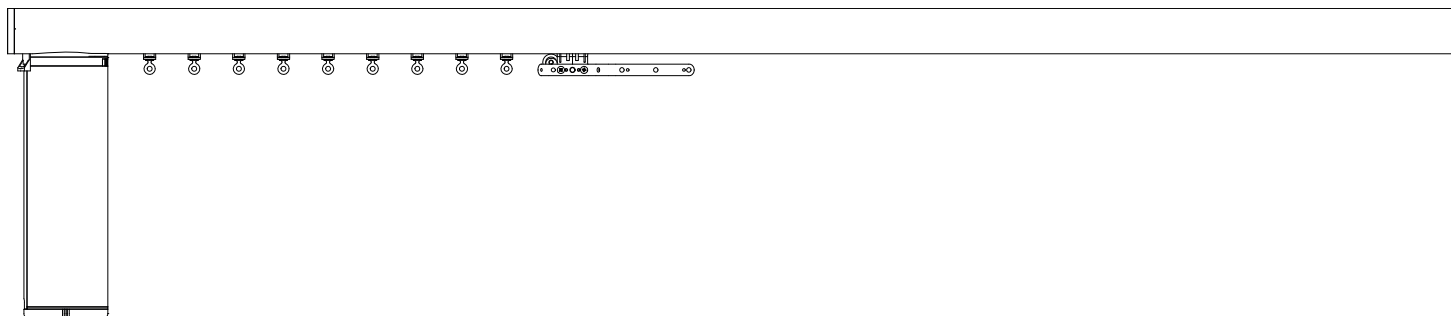

Supplied with 1x Overlap Arm. 1x Motor Hook.

Electric - Somfy - Pair Stack → ←

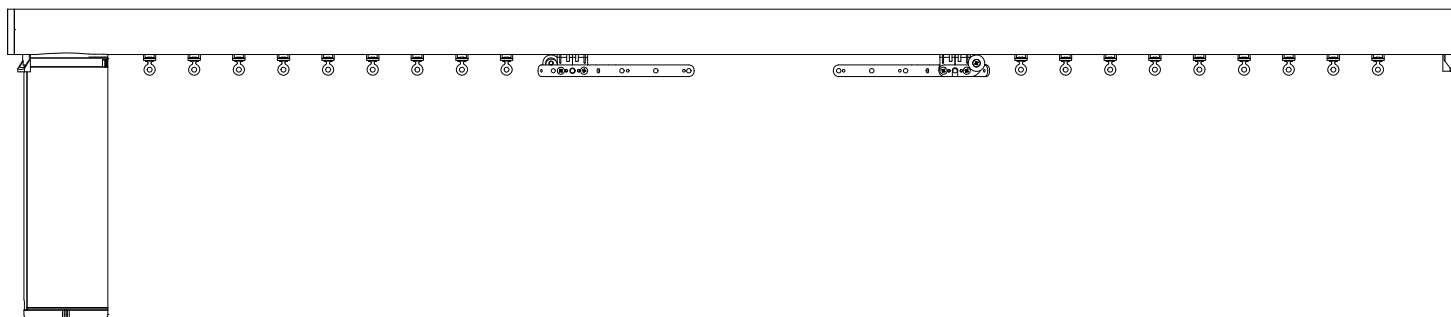

Supplied with 2x Overlap Arm. 1x Motor Hook. 1x Return Hook.

ECLIPSE Electric - Somfy • Configurations - Ripple Rollers

Eclipse ordered with Ripple Rollers will be supplied as per the diagrams below.

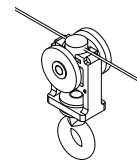

Electric - Somfy - Single Stack →

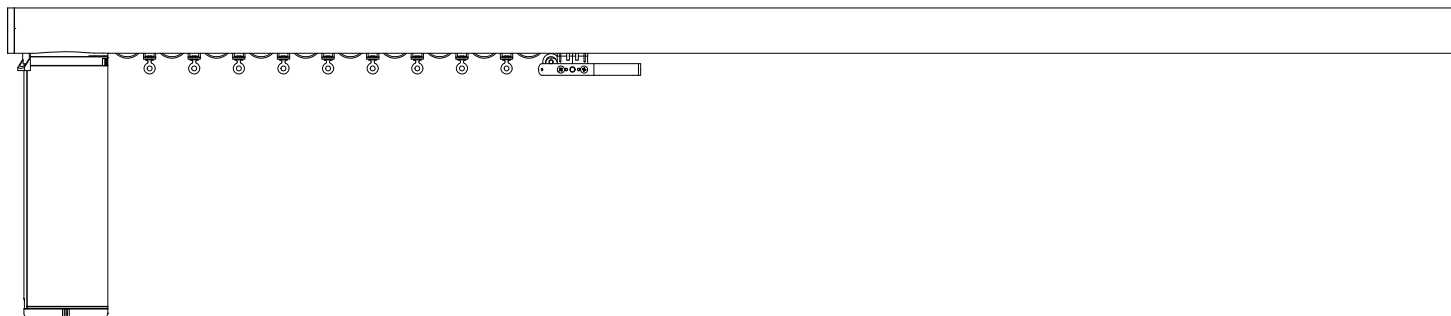

Supplied with 1x Ripple Arm. 1x Motor Hook.

Electric - Somfy - Pair Stack →←

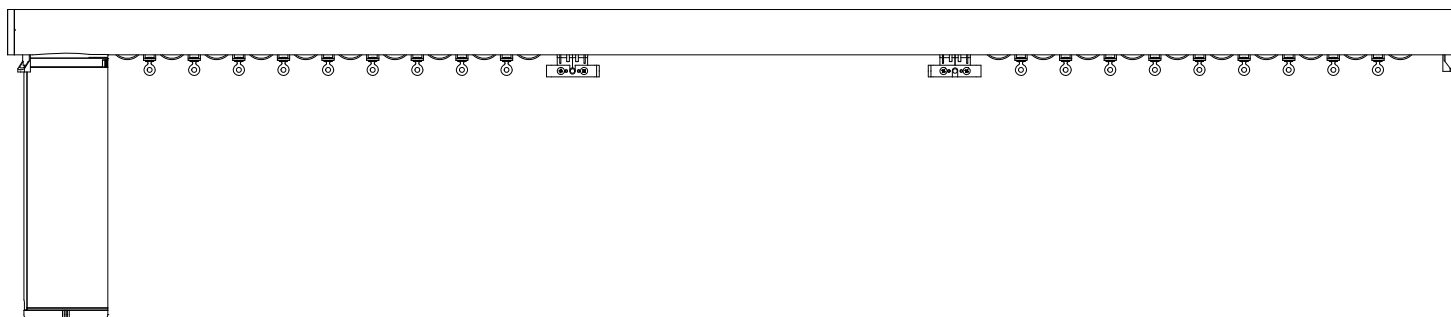

Supplied with 2x Ripple Butt Arm. 1x Motor Hook. 1x Return Hook.

ECLIPSE Coverpole - Somfy • Ø38mm (1 1/2") - Left Hand Motor

Finishes Alabaster • Dusk • Granite • Slate • Flint • Barley • Dove • Millstone • Clay • Cocoa • Cloud • Ceramic • Bone • Cream • Parchment • Damson • Moss • Smoke • Frame Grey • Raven **Coat Options** Matte (M) • Satin (S) • Gloss (G) Platinum • Champagne • Gold • Cognac • Gunmetal • Antique Brass • Pewter • Bronzed **Coat Options** Satin (S) • Gloss (G)
Progressive (Additional to above) Brushed Stainless • Brushed Brass Tint • Brushed Bronze Tint • Brushed Carbon Tint
Classic (Additional to above) Polished • Natural Steel • Brass Toned • Matte Brass Toned • Oil Rubbed • Waxed

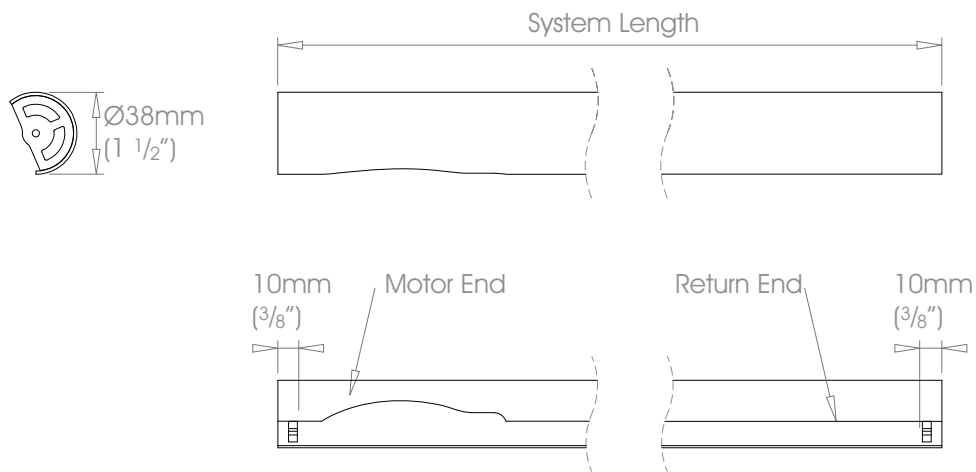

38mm (1 1/2") Coverpole - Left Hand Motor

ECLIPSE Coverpole - Somfy • Ø38mm (1 1/2") - Right Hand Motor

Finishes Alabaster • Dusk • Granite • Slate • Flint • Barley • Dove • Millstone • Clay • Cocoa • Cloud • Ceramic • Bone • Cream • Parchment • Damson • Moss • Smoke • Frame Grey • Raven **Coat Options** Matte (M) • Satin (S) • Gloss (G) Platinum • Champagne • Gold • Cognac • Gunmetal • Antique Brass • Pewter • Bronzed **Coat Options** Satin (S) • Gloss (G)
Progressive (Additional to above) Brushed Stainless • Brushed Brass Tint • Brushed Bronze Tint • Brushed Carbon Tint
Classic (Additional to above) Polished • Natural Steel • Brass Toned • Matte Brass Toned • Oil Rubbed • Waxed

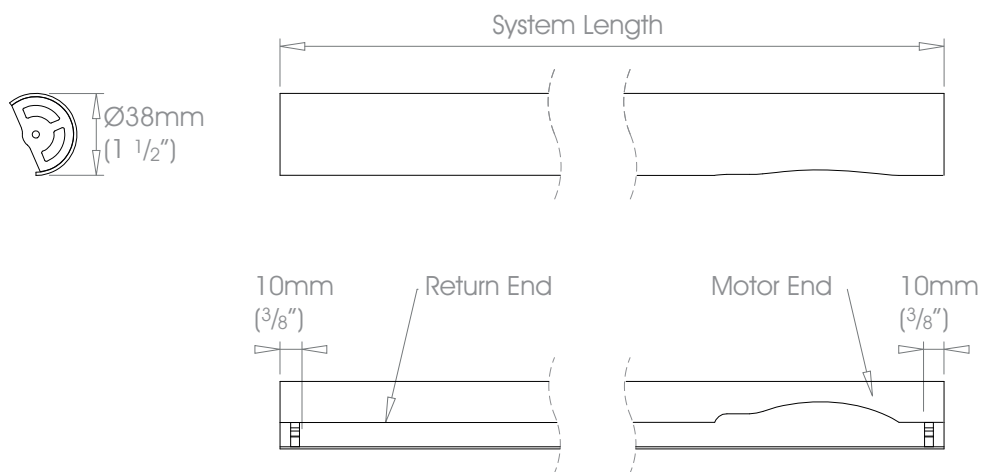

38mm (1 1/2") Coverpole - Right Hand Motor

ECLIPSE Coverpole - Somfy • Ø50mm (2") - Left Hand Motor

Finishes

Alabaster • Dusk • Granite • Slate • Flint • Barley • Dove • Millstone • Clay • Cocoa • Cloud • Ceramic • Bone • Cream • Parchment • Damson • Moss • Smoke • Frame Grey • Raven
Coat Options Matte (M) • Satin (S) • Gloss (G) • Paint on Tulip Wood (T)
 Platinum • Champagne • Gold • Cognac • Gunmetal • Antique Brass • Pewter • Bronzed
Coat Options Satin (S) • Gloss (G)
Progressive (Additional to above) Brushed Stainless • Brushed Brass Tint • Brushed Bronze Tint • Brushed Carbon Tint
Classic (Additional to above) Polished • Natural Steel • Brass Toned • Matte Brass Toned • Oil Rubbed • Waxed
Deco (Additional to above) Aged Brass* • Waxed Brass* • Polished Brass • Aged Oak • Jacobean Oak • Antique Mahogany • Ebony



* Brass finishes are supplied unlacquered & will tarnish over time a clear lacquer may be applied on request as a custom finish.

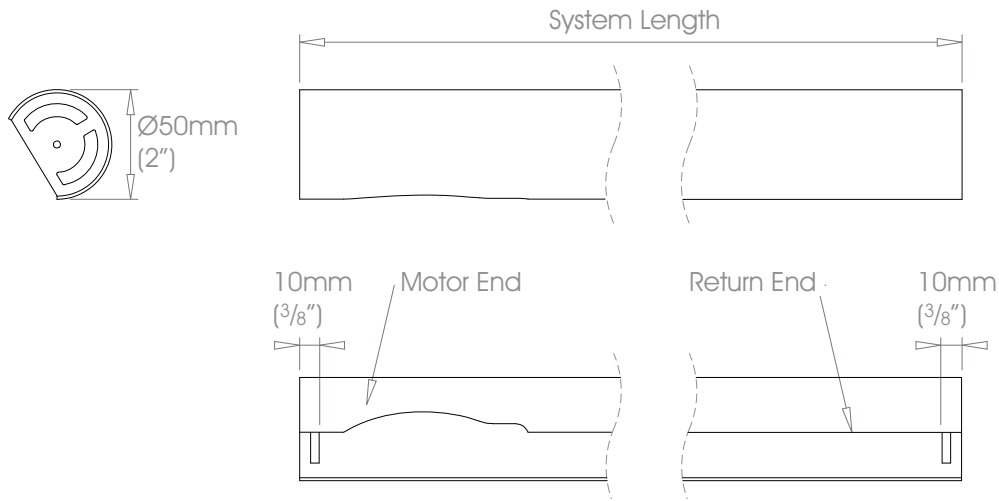

50mm (2") Coverpole - Left Hand Motor

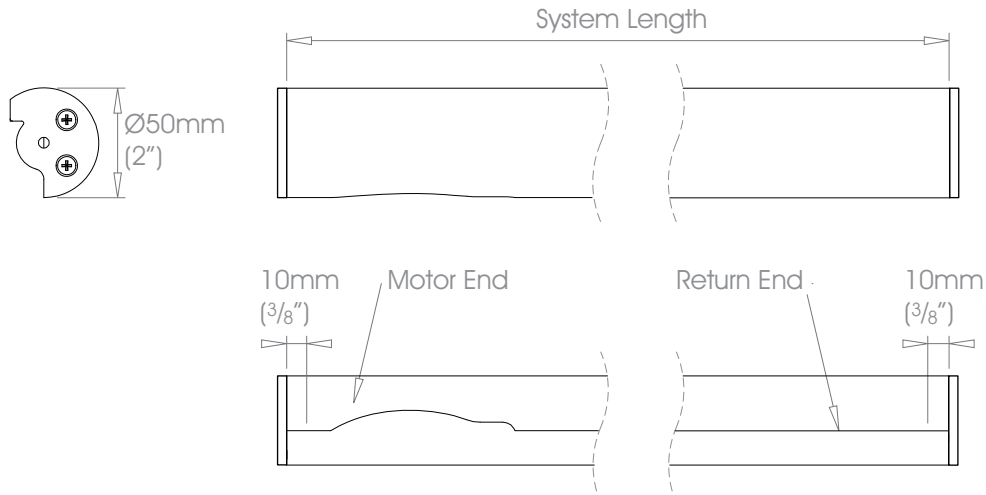

50mm (2") Wood Coverpole - Left Hand Motor

ECLIPSE Coverpole - Somfy • Ø50mm (2") - Right Hand Motor

Finishes

Alabaster • Dusk • Granite • Slate • Flint • Barley • Dove • Millstone • Clay • Cocoa • Cloud • Ceramic • Bone • Cream • Parchment • Damson • Moss • Smoke • Frame Grey • Raven
Coat Options Matte (M) • Satin (S) • Gloss (G) • Paint on Tulip Wood (T)
 Platinum • Champagne • Gold • Cognac • Gunmetal • Antique Brass • Pewter • Bronzed
Coat Options Satin (S) • Gloss (G)
Progressive (Additional to above) Brushed Stainless • Brushed Brass Tint • Brushed Bronze Tint • Brushed Carbon Tint
Classic (Additional to above) Polished • Natural Steel • Brass Toned • Matte Brass Toned • Oil Rubbed • Waxed
Deco (Additional to above) Aged Brass* • Waxed Brass* • Polished Brass • Aged Oak • Jacobean Oak • Antique Mahogany • Ebony



* Brass finishes are supplied unlacquered & will tarnish over time a clear lacquer may be applied on request as a custom finish.

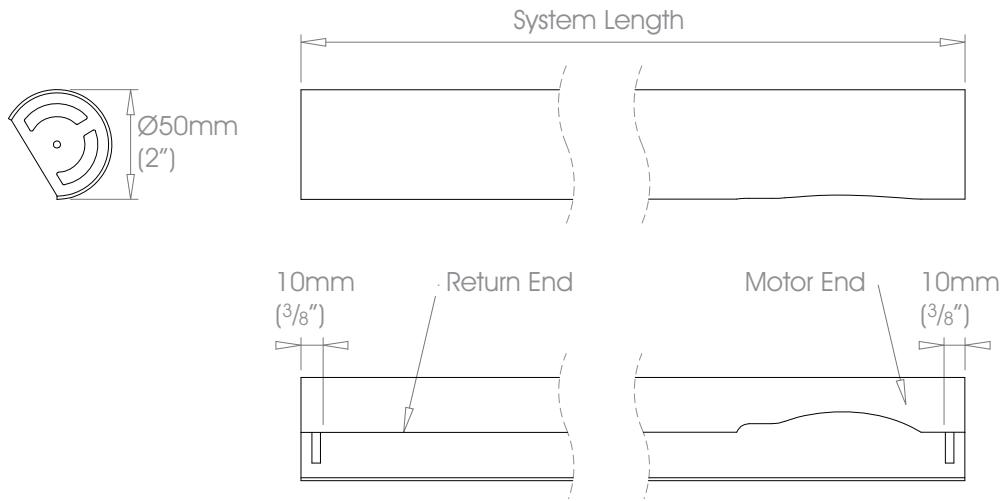

50mm (2") Coverpole - Right Hand Motor

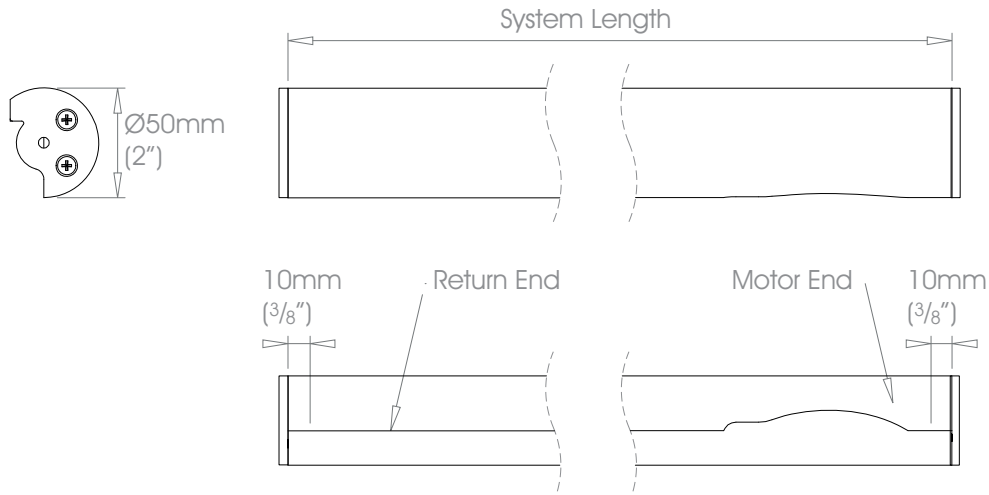

50mm (2") Wood Coverpole - Right Hand Motor

ECLIPSE Electric - Somfy® • Track

Finishes Track will be finished in a complementary colour to match the cover pole see table on page 7 for details.

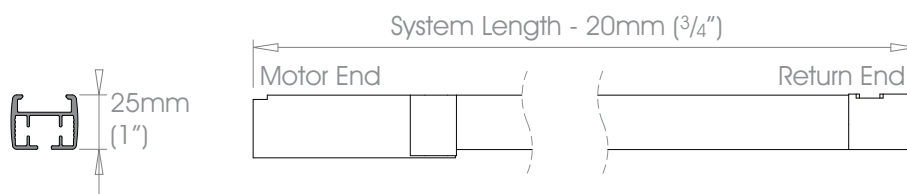

Somfy Motorised Track - Left Hand

 Rollers Single stack → up to 12m (39')*
Pair stack →← up to 12m (39')*

 Ripple - Rollers Single stack → up to 12m (39')*
Pair stack →← up to 12m (39')*

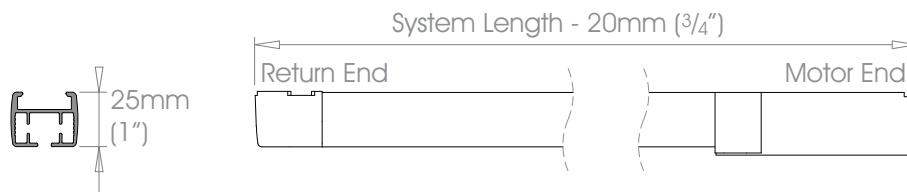

Somfy Motorised Track - Right Hand

 Rollers Single stack → up to 12m (39')*
Pair stack →← up to 12m (39')*

 Ripple - Rollers Single stack → up to 12m (39')*
Pair stack →← up to 12m (39')*

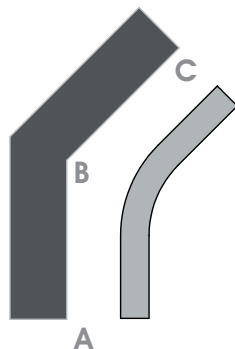

Minimum wall sizes and projections Based on 135° bend angles

Diameter	Wall A - B	Wall B - C	Minimum coverpole bend radius	Minimum internal track bend radius	Minimum projection
38mm (1 1/2")	300mm (11 13/16")	300mm (11 13/16")	254mm (10")	275mm (10 13/16")	100mm (4")
50mm (2")	300mm (11 13/16")	300mm (11 13/16")	254mm (10")	275mm (10 13/16")	100mm (4")

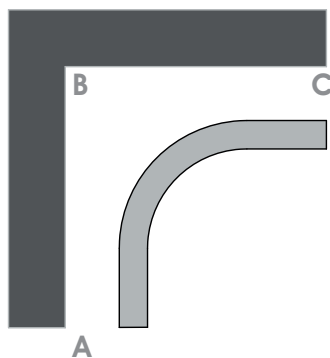

Minimum wall sizes and projections Based on 90° bend angles

Diameter	Wall A - B	Wall B - C	Minimum coverpole bend radius	Minimum internal track bend radius	Minimum projection
38mm (1 1/2")	500mm (19 11/16")	500mm (19 11/16")	254mm (10")	275mm (10 13/16")	100mm (4")
50mm (2")	500mm (19 11/16")	500mm (19 11/16")	254mm (10")	275mm (10 13/16")	100mm (4")

Please note, return bends & continuous curves are not available.

ECLIPSE Electric - Somfy® • Coverpole + Track Bay Bends

Finishes

Alabaster • Dusk • Granite • Slate • Flint • Barley • Dove • Millstone • Clay • Cocoa • Cloud • Ceramic • Bone • Cream • Parchment • Damson • Moss • Smoke • Frame Grey • Raven
Coat Options Matte (M) • Satin (S) • Gloss (G) • Paint on Tulip Wood (T)
 Platinum • Champagne • Gold • Cognac • Gunmetal • Antique Brass • Pewter • Bronzed
Coat Options Satin (S) • Gloss (G)
Progressive (Additional to above) Brushed Stainless • Brushed Brass Tint • Brushed Bronze Tint • Brushed Carbon Tint
Classic (Additional to above) Polished • Natural Steel • Brass Toned • Matte Brass Toned • Oil Rubbed • Waxed
Deco (Additional to above) Aged Brass* • Waxed Brass* • Polished Brass • Aged Oak • Jacobean Oak • Antique Mahogany • Ebony

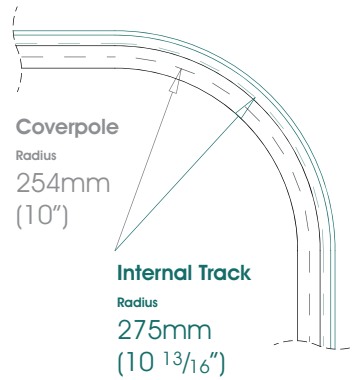

30mm (1 3/16") Not Available

38mm (1 1/2") Coverpole + Track Bay Bend

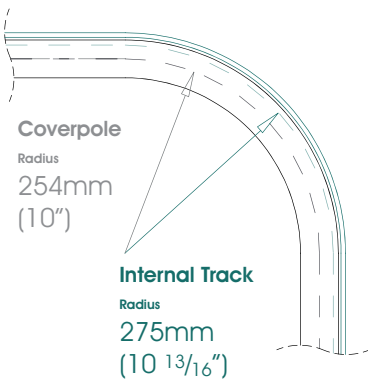

50mm (2") Coverpole + Track Bay Bend

Please note
 Brushed Stainless & Brushed tint finish options not available
 Return bends are not available

ECLIPSE Curtain Information • Drops - \varnothing 38mm (1 1/2") - Somfy Systems

The information below shows the relationship between the \varnothing 38mm (1 1/2") coverpole, track, brackets and rollers. This will enable the correlation between pole heights and curtain drops to be easily calculated. Bracket projection measurements are from the back wall the centre of the track and are a good indicator of where the curtain will fall. The coverpole sits 19mm (3/4") in-front of track centre. Ceiling bracket drop measurements are from the ceiling to the top of the pole.

Single System - \varnothing 38mm (1 1/2") Coverpole

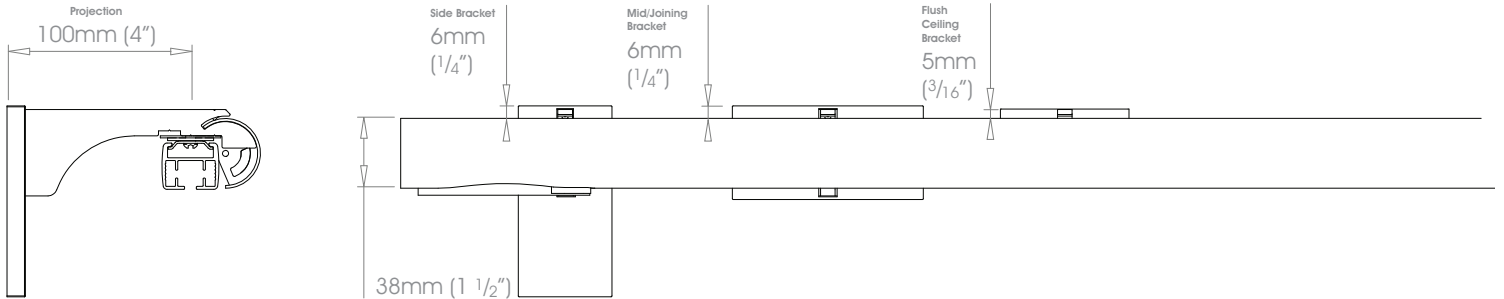

Double System - Front \varnothing 38mm (1 1/2") Coverpole + Back \varnothing 30mm (1 3/16") Coverpole

The back pole is 30mm (1 3/16") and is suitable for use with, Hand Drawn & Electric - Silent Gliss 5600 options. Please refer to the relevant Specification Guides for more information.

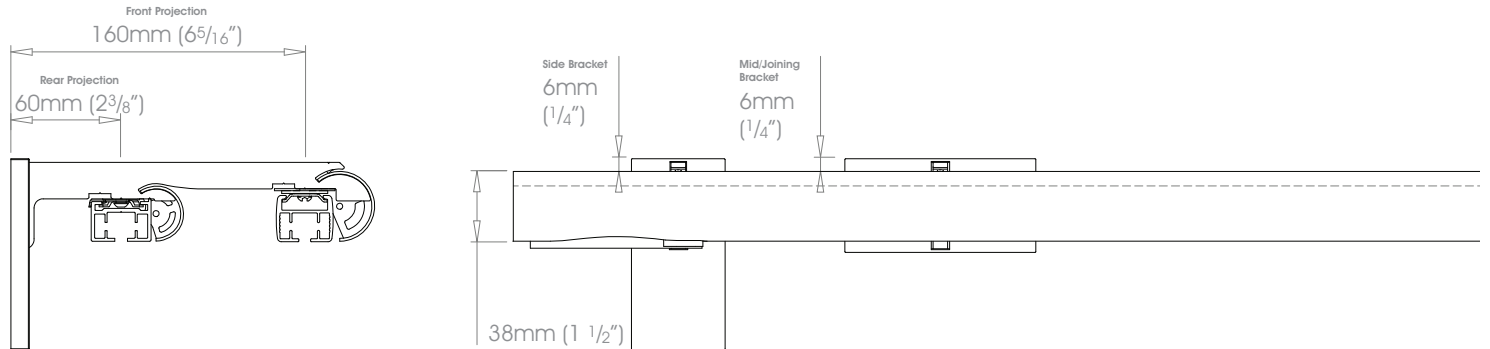

Pin Hook Measurement

From bottom of the track

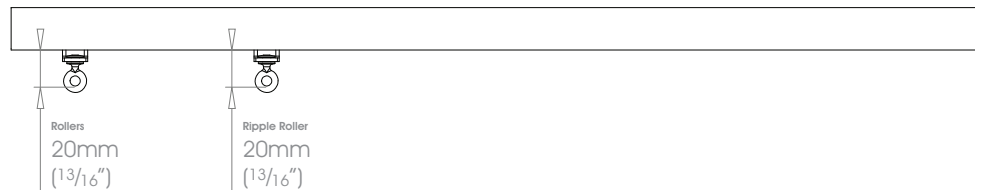

ECLIPSE Curtain Information • Drops - \varnothing 50mm (2") - Somfy Systems

The information below shows the relationship between the \varnothing 50mm (2") coverpole, track, brackets and rollers. This will enable the correlation between pole heights and curtain drops to be easily calculated. Bracket projection measurements are from the back wall the centre of the track and are a good indicator of where the curtain will fall. The coverpole sits 19mm ($\frac{3}{4}$ ") in-front of track centre. Ceiling bracket drop measurements are from the ceiling to the top of the pole.

Single System - \varnothing 50mm (2") Coverpole

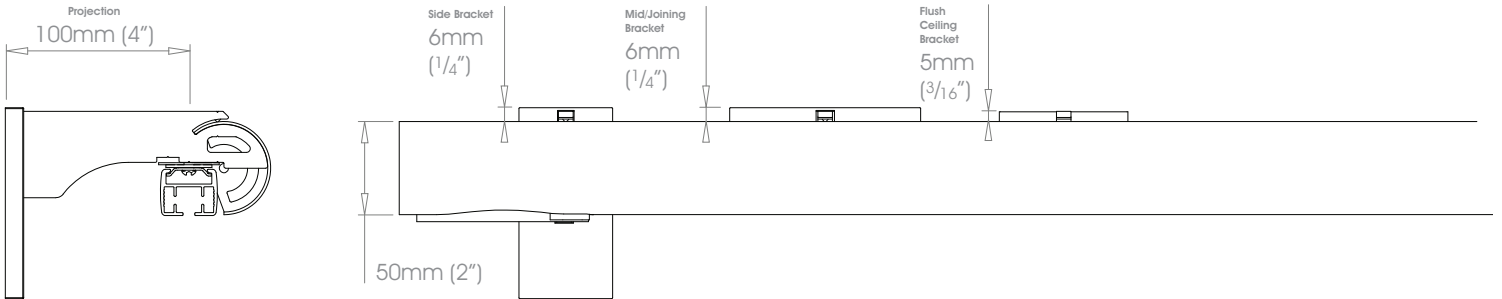

Double System - Front \varnothing 50mm (2") Coverpole + Back \varnothing 38mm (1 1/2") Coverpole

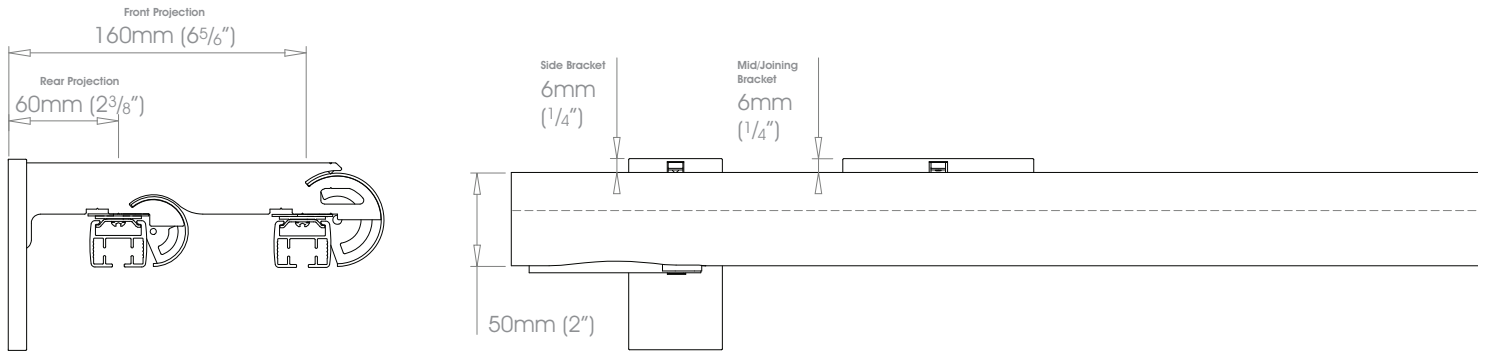

Pin Hook Measurement

From bottom of the track



Stacking

This is the area where the curtains hang against the wall when they are pulled open. by covering the wall and not the glass, during the day, it allows more light into the room.

Allow 30% of the length of the track for curtain stacking. very full curtains (e.g. pencil pleat) will need more space than flatter ones. lined and interlined curtains will also require more stacking space than unlined.

Overlap arms are supplied with Electric systems using Rollers. Ripple systems are not compatible with overlap arms, the curtains are designed to butt together.

Stacking Options

With electric systems stacking options are configured at the point of assembly, so must be specified when ordering.

Single or pair stack Ripple curtain stacking must be specified when ordering as this will affect the number of rollers installed into the pole.

Single stack →



Pair stack →←



Standard Rollers - Pinch Pleat

Pinch pleat style is named for the pleated look created by pinched gatherings of the fabric at the top of the drapery. Pins on the back of the drapery are simply looped through the rollers of the track when installed

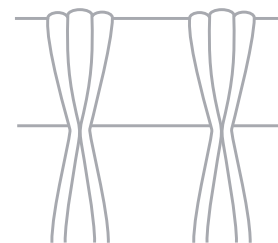

Ripple rollers

Ripple is a simple **S** folded heading system consisting of rollers spaced by a cord and a special pocketed header tape that is sewn onto a flat panel curtain. When assembled in the pole, the rollers on the cord are spaced at distance shown below and this fixes the 'pitch' of the ripple. The flat panel curtain(s) are made in the conventional way with the pocketed header tape sewn to the header. Hooks are fitted to header tape at a set spacing creating the ripple effect

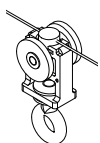
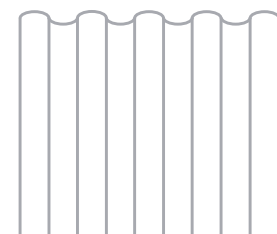

Ripple rollers

80mm (3 1/8") spacing between the rollers. **(standard)**

Roller-Cord Spacing	Curtain Hook Spacing	Approx. Curtain Fullness	Stack Depth	Min Bracket Projection
80mm (3 1/8")	160mm (6 5/16")	2.3	180mm (7 1/16") per 1M (39 3/8") of pole	100mm (4")

Curtain Weights

Different types of fabric have widely differing weights. The type of curtain heading used (see below) will determine the fullness of the fabric used; this can be anything from 1.5 x the width of the pole to 3.0 x pole width.

The chart below assumes 100% fullness (2.0 x width of the pole) the weights are very approx and can vary for many reasons. Always check the expected and final total curtain weight with the curtain maker. based on 1200mm (48") fabric width

Curtain Type	Width↓ /Drop→	1m (3.5')	2m (7')	3m (10.5')	4m (14')	5m (16.5')	6m (20')
Print Cotton (Light)	1m (3.5')	0.8kg (1.8lb)	1.7kg (3.7lb)	2.5kg (5.5lb)	3.4kg (7.4lb)	4.2kg (9.2lb)	5.0kg (11.1lb)
	2m (7')	1.3kg (2.8lb)	2.5kg (5.5lb)	3.8kg (8.3lb)	5kg (11.1lb)	6.3kg (13.9lb)	7.6kg (16.6lb)
	3m (10')	1.7kg (3.7lb)	3.4kg (7.4lb)	5kg (11.1lb)	6.7kg (14.8lb)	8.4kg (18.5lb)	10kg (22lb)
Linen (Medium)	1m (3.5')	1.1kg (2.3lb)	2.1kg (4.6lb)	3.2kg (6.9lb)	4.2kg (9.2lb)	5.3kg (11.6lb)	6.3kg (13.9lb)
	2m (7')	1.6kg (3.5lb)	3.2kg (6.9lb)	4.7kg (10.4lb)	6.3kg (13.9lb)	7.9kg (17.3lb)	9.5kg (20.8lb)
	3m (10')	2.1kg (4.6lb)	4.2kg (9.2lb)	6.3kg (13.9lb)	8.4kg (18.5lb)	10.5kg (23.1lb)	12.6kg (27.7lb)
Velvet (Heavy)	1m (3.5')	1.5kg (3.2lb)	3.2kg (6.5lb)	4.4kg (9.7lb)	5.9kg (12.9lb)	7.4kg (16.2lb)	8.8kg (19.4lb)
	2m (7')	2.2kg (4.9lb)	4.4kg (9.7lb)	6.7kg (12.6lb)	8.8kg (19.4lb)	11kg (24.3lb)	13.2kg (22lb)
	3m (10')	2.9kg (6.5lb)	5.9kg (12.9lb)	8.8kg (19.4lb)	11.8kg (26lb)	14.7kg (32.2lb)	17.6kg (39lb)

ECLIPSE Curtain Information • Somfy Maximum Weights

Maximum weight recommendations for all standard curtain types using rollers are defined to ensure safe and proper function of the electric system. These must be adhered to. See table below for details of all options.

Somfy® Movelite 35 Motor

Rollers One roller is specified for every 100mm (4").
Ripple Rollers 80mm (3 1/8") spacing between the rollers.

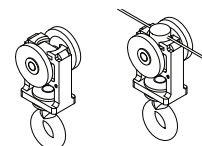

System Width Single Stack → / Pair Stack →←	Straight	1 Bend Bay	2 Bend Bay	4 Bend Bay
3m (10')	35kg (77lb)	n/a	n/a	n/a
6m (19.5')	35kg (77lb)	n/a	n/a	n/a

Somfy® Glydea Ultra 60e Motor

Rollers One roller is specified for every 100mm (4").
Ripple Rollers 80mm (3 1/8") spacing between the rollers.

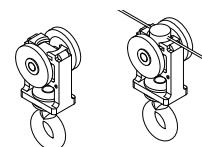

System Width Single Stack → / Pair Stack →←	Straight	1 Bend Bay	2 Bend Bay	4 Bend Bay
3m (10')	60kg (132lb)	45kg (99lb)	35kg (77lb)	n/a*
6m (19.5')	60kg (132lb)	45kg (99lb)	35kg (77lb)	n/a*
10m (33')	60kg (132lb)	45kg (99lb)	25kg (55lb)	n/a*
11m (36')	55kg (121.2lb)	35kg (77lb)	n/a	n/a*

Somfy® Irismo 45 Motor

Rollers One roller is specified for every 100mm (4").
Ripple Rollers 80mm (3 1/8") spacing between the rollers.

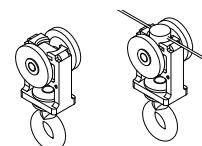

System Width Single Stack → / Pair Stack →←	Straight	1 Bend Bay	2 Bend Bay	4 Bend Bay
3m (10')	45kg (99lb)	45kg (99lb)	35kg (77lb)	n/a*
6m (19.5')	45kg (99lb)	45kg (99lb)	30kg (66lb)	n/a*
10m (33')	45kg (99lb)	35kg (77lb)	25kg (55lb)	n/a*

* no data available - additional bends will reduce the load bearing capability of they system

ECLIPSE Electric - Somfy® • Movelite 35 Motor

Somfy® Movelite 35 Motor

Size	L265mm (10 7/16") x W93mm (3 11/16") x D53mm (2 1/16")
Power Supply	90 - 255V, 50/60 Hz
Average Speed	150mm/s (6"/s)
Noise	< 41 dBA
Max Length	6m (19.5')
Max Weight	35kg (77lb)
Control	WT, DCT, RTS
Colour Options	White (Plastic housing will be supplied in White)

WT Motor 4 core cable
Mains switching
Controlled with automation systems or hard wired wall switch

DCT Motor 3 core cable
Dry contact, Volt free switching
Controlled with automation systems via volt free or RTS / volt free hard wired wall switch

RTS Motor 3 core cable
Built in radio receiver
Dry contact, Volt free switching
Controlled with Somfy remote or app control options / automation systems via volt free or RTS / volt free hard wired wall switch



Motor Features

Movelite 35 WT

Movelite 35 DCT

Movelite 35 RTS

Motor Features	Movelite 35 WT	Movelite 35 DCT	Movelite 35 RTS
Soft Start	✗	✗	✗
Soft Stop	✗	✗	✗
Intermediate Position	✓	✗	✓
Manual Override	✓	✓	✓
Touch Motion	✓	✗	✓
Automatic Limits on End Stop	✓	✓	✓
Back Release	✗	✗	✗
Adjustable Limits	✓	✗	✓
Speed Control & Adjustment	✗	✗	✗
Set via 3 NO Dry Contact Setting tool	✓	✓	✓
Setting with button on motor	✗	✗	✗
Motor direction change	✓	✓	✓
DCT ergonomics setting 2 or 3 buttons	✓	✗	✓
Factory reset	✓	✓	✓
LED indicators	✗	✗	✗
Modulability	✗	✗	✗
Silent mode	✗	✗	✗
Buzzer indicators	✗	✗	✗
Remote control	✗	✗	✓
App control	✗	✗	✓

ECLIPSE Electric - Somfy® • Glydea Ultra 60e Motor

Somfy® Glydea Ultra 60e Motor

Size	L291mm (11 7/16") x W93mm (3 11/16") x D53mm (2 1/16")
Power Supply	120V, 50/60 Hz
Average Speed	Normal Mode: 127mm/s (5"/s - 8"/s) / Silent mode - 75mm/s (3"/s)
Noise	< 38 dBA in Silent mode
Max Length	11m (36')
Max Weight	60kg (132lb)
Control	WT, DCT, RTS
Colour Options	White (Plastic housing will be supplied in White)

WT Motor 4 core cable
 Mains switching
 Controlled with automation systems or hard wired wall switch

DCT Motor 3 core cable
 Dry contact, Volt free switching
 Controlled with automation systems via volt free or RTS / volt free hard wired wall switch

RTS Motor 3 core cable
 Built in radio receiver
 Dry contact, Volt free switching
 Controlled with Somfy remote or app control options / automation systems via volt free or RTS / volt free hard wired wall switch



Motor Features

Glydea Ultra 60e WT

Glydea Ultra 60e DCT

Glydea Ultra 60e RTS

Motor Features	Glydea Ultra 60e WT	Glydea Ultra 60e DCT	Glydea Ultra 60e RTS
Soft Start	✓	✓	✓
Soft Stop	✗	✓	✓
Intermediate Position	✗	✓	✓
Manual Override	✓	✓	✓
Touch Motion	✗	✓	✓
Automatic Limits on End Stop	✓	✓	✓
Back Release	✓	✗	✗
Adjustable Limits	✗	✓	✓
Speed Control & Adjustment	✓	✓	✓
Set via 3 NO Dry Contact Setting tool	✓	✓	✓
Setting with button on motor	✓	✓	✓
Motor direction change	✓	✓	✓
DCT ergonomics setting 2 or 3 buttons	✗	✓	✓
Factory reset	✓	✓	✓
LED indicators	✓	✓	✓
Modulability	✗	✓	✓
Silent mode	✓	✓	✓
Buzzer indicators	✗	✗	✗
Remote control	✗	✗	✓
App control	✗	✗	✓

ECLIPSE Electric - Somfy® • Irismo 45 Motor

Somfy® Irismo 45 Motor

Size	L308mm (12 1/8") x W93mm (3 11/16") x D53mm (2 1/16")
Power Supply	26.6 Li-Ion
Battery Pack	2950 mAh
Battery Life	Single Charge last's 9 months
Average Speed	100-250v AC
Noise	< 44 dBA
Max Length	10m (33')
Max Weight	45kg (99lb)
Control	RTS
Colour Options	White (Plastic housing will be supplied in White)

RTS Motor	Battery Powered Wire free Built in radio receiver Controlled with Somfy remote or app control options / automation systems via RTS
-----------	---------------------------------------------------------------------------------------------------------------------------------------------



Motor Features

Irismo Wirefree 45 RTS

Soft Start	✓
Soft Stop	✓
Intermediate Position	✓
Manual Override	✓
Touch Motion	✓
Automatic Limits on End Stop	✓
Back Release	✗
Adjustable Limits	✓
Speed Control & Adjustment	✓
Set via 3 NO Dry Contact Setting tool	✗
Setting with button on motor	✗
Motor direction change	✓
DCT ergonomics setting 2 or 3 buttons	✗
Factory reset	✓
LED indicators	✓
Modulability	✗
Silent mode	✗
Buzzer indicators	✓
Remote control	✓
App control	✓

Remote Control - Multi Channel

Multi channel remote can control multiple motors independently or grouped together.



Wall Control - Single Channel

Single channel wall remote can control one motor or a group of motors at the same time.



App Control

The system can be controlled with the Somfy Tahoma app or through smart devices & Amazon Alexa.

The system can also be integrated with all major home control systems.





Telis 4 Remote Control - Multi Channel Remote 4+1

Compatible with the Somfy RTS range of motors and sensors.
For indoor use

The multi channel remote can operate up to four motors individually or up to five groups of motors individually or simultaneously.

Size 145 x 49 x 22 mm

Water Rating IP 30

Battery Type 2430 Lithium - 3V

Channel 5

Frequency 433.42 MHz

Range 200m in open field or 20m through 2 reinforce concrete walls

Colour White

Misc Wall holder included



Smoove Origin Wall Switch - Single Channel

Single channel remote can operate one motor or one group of motors simultaneously.

Size 80 x 80 x 10 mm

Water Rating IP 30

Battery Type LR03 AAA - 1.5 V

Channel 1

Frequency 433.42 MHz

Range 200m in open field or 20m through 2 reinforce concrete walls

Colour White

Misc Wall holder included

HAND DRAWN

For windows or double treatments where motorisation is not required,
hand drawn versions are also available.

ECLIPSE Coverpole & Hand Drawn Track Information

Coverpole & Internal Track Relationship

Eclipse is made up of a decorative round coverpole which can either be manufactured in steel, stainless steel. With a concealed smooth running aluminium track sitting behind it. The diagrams below shows the relationship between the two components

Available pole diameter's - $\varnothing 30\text{mm}$ ($1\frac{3}{16}$ ") • 38mm ($1\frac{1}{2}$ ") • 50mm (2 ")

The overall pole cost is rounded up in 300mm (1ft) increments.

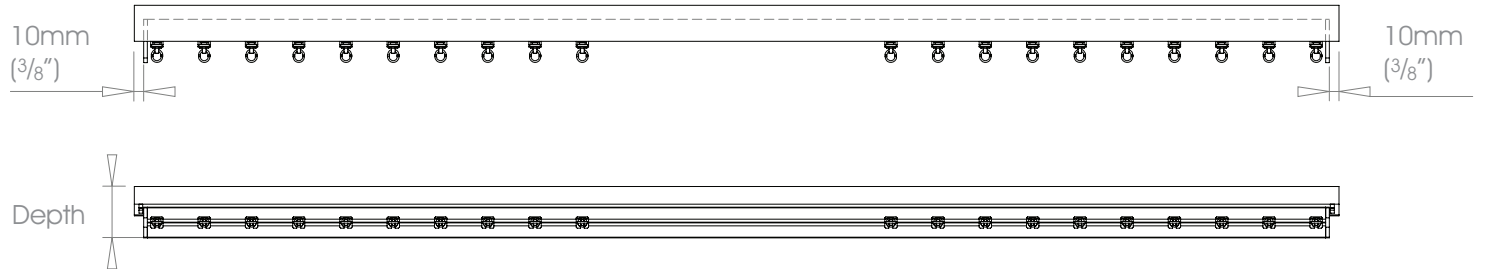
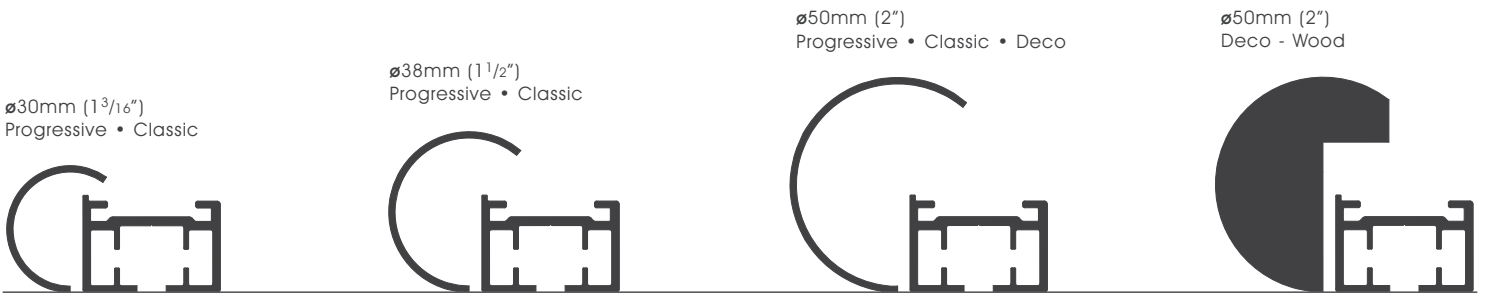

Diameter	Depth A	Depth B
$\varnothing 30\text{mm}$ ($1\frac{3}{16}$ ")	50mm ($1\frac{15}{16}$ ")	64mm ($2\frac{1}{2}$ ")
$\varnothing 38\text{mm}$ ($1\frac{1}{2}$ ")	55mm ($2\frac{1}{8}$ ")	68mm ($2\frac{11}{16}$ ")
$\varnothing 50\text{mm}$ (2 ")	61mm ($2\frac{3}{8}$ ")	75mm ($2\frac{15}{16}$ ")

! Over collar finials from Simple, Stainless & Elysian collections can be supplied on request. Please note it will reduce the overall track length shown above, by an additional 15mm ($\frac{9}{16}$ ")

ECLIPSE Coverpole & Hand Drawn Track Information

Providing Pole Lengths

Pole lengths can be specified in two ways, Option A is our preferred method. This covers pole length only, the second option combines pole and finial lengths

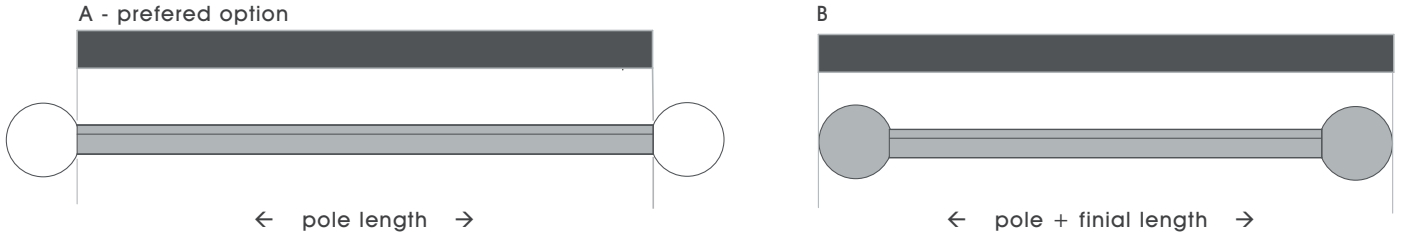

Poles are cut, bent and curved to suit individual requirements.

When calculating the length of your pole, remember to allow tolerance beyond the width of the frame for the curtains to draw back to the edge of the window.

Maximum pole length in one piece 2.9m (114").

Poles exceeding the recommended maximum distance between brackets, will be cut into equal parts unless otherwise specified. Pole joiners will be supplied. Mid or passing brackets should be placed at every join.

Glider/Roller Type	Maximum System Length - Single Stack →	Maximum System Length - Pair Stack →←	Maximum Coverpole Section Length	Maximum Track Section Length	Bracket Spacing
Glider	3000mm (10')	6000mm (20')	2900mm (9'6")	3000mm (10')	1500mm (5')
Roller	6000mm (20')	6000mm (20')	2900mm (9'6")	3000mm (10')	1500mm (5')
Wave - Glider	3000mm (10')	6000mm (20')	2900mm (9'6")	3000mm (10')	1500mm (5')
Wave - Roller	6000mm (20')	6000mm (20')	2900mm (9'6")	3000mm (10')	1500mm (5')
Ripplefold - Roller	6000mm (20')	6000mm (20')	2900mm (9'6")	3000mm (10')	1500mm (5')

Bespoke Bays

Bradley's bespoke service allows poles to be specifically made for unique bay windows and complex long

Please note, return bends & continuous curves are not available

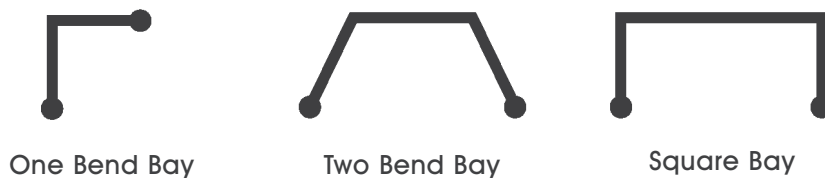

ECLIPSE Coverpole & Hand Drawn Track Information

Joining Poles

Where ever there is a join in the coverpole, this must always be supported by a joining bracket. Two clamps sit on top of the bracket to support the coverpole, a joiner sits under the bracket and slides into the top channel of the track. to keep the two parts securely together

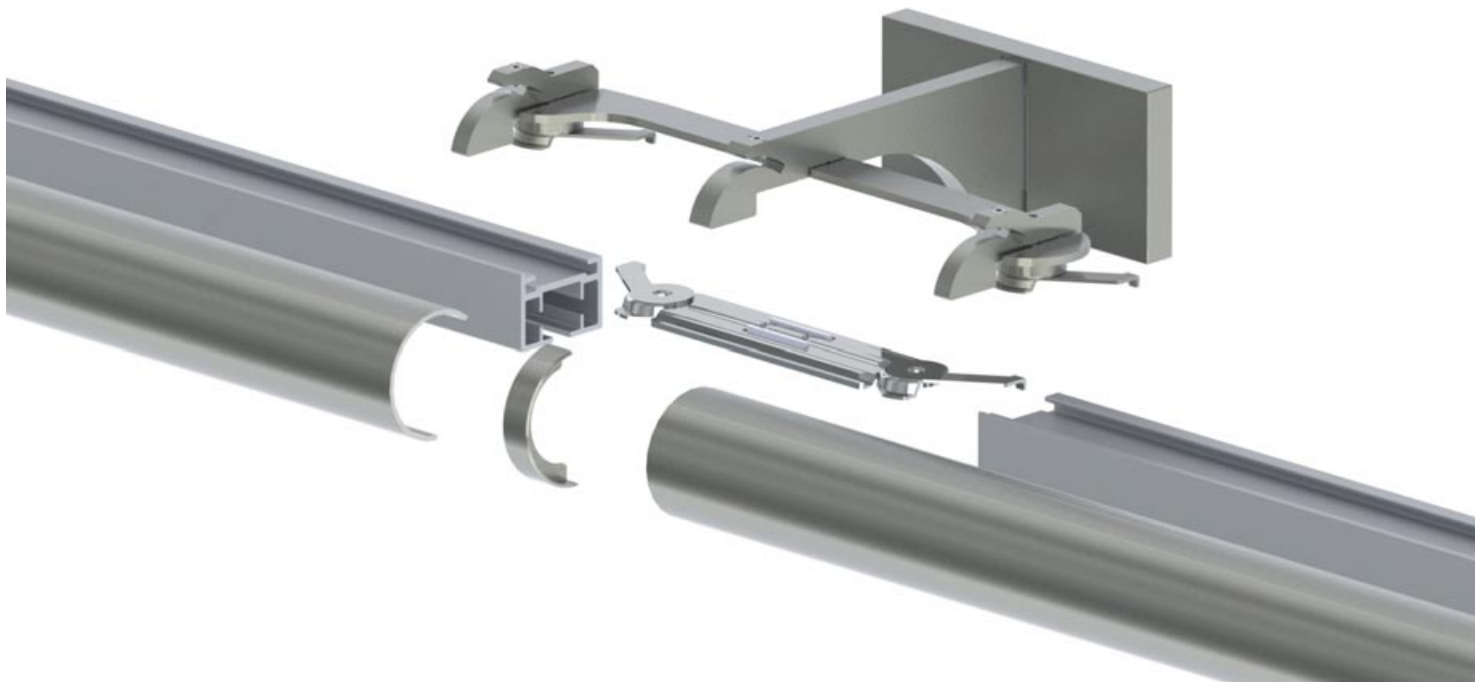

Intermediate support clamps

Intermediate support clamps are designed to support between brackets. keeping the coverpole and track together.

A intermediate support clamp may be required when the drapes are opened and are stacked at the ends of the system, and on bay bends.



ECLIPSE Coverpole & Hand Drawn Track Information

Hand Drawn curtain poles

Eclipse consists of a decorative coverpole and finial concealing a functional track system, with the assembly clamped together by clever bracket design.

Coverpoles over 2.9m (9'6") in length will be supplied in multiple sections, tracks over 2.9m (9'6") will be supplied in multiple sections Z folded and pre-assembled with drive belt and gliders/rollers ready for connecting and installing.

Select cover pole

Available cover pole diameter's - $\varnothing 30\text{mm}$ (1 $\frac{3}{16}$ ") • 38mm (1 $\frac{1}{2}$ ") • 50mm (2")

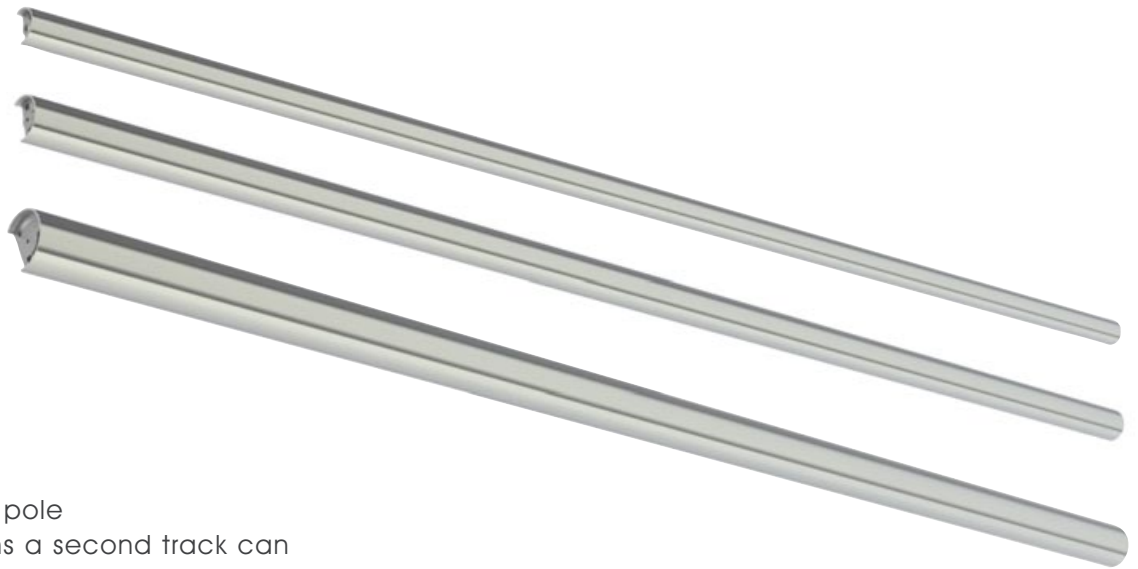

Add hand drawn track

Can be used in a cover pole
For double configurations a second track can be specified to fit behind the cover pole



Select Glider/Roller Option

Select from gliders and rollers or wave[®] gliders and rollers



ECLIPSE Hand Drawn • Configurations - Gliders & Rollers

Poles ordered with Standard Gliders & Rollers & Wave Gliders & Rollers will be supplied as per the diagrams below.

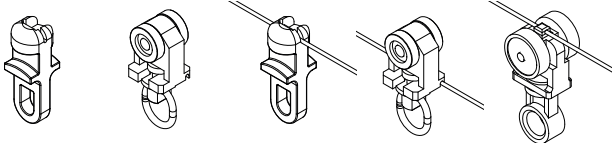

Hand Drawn System - Single Stack →

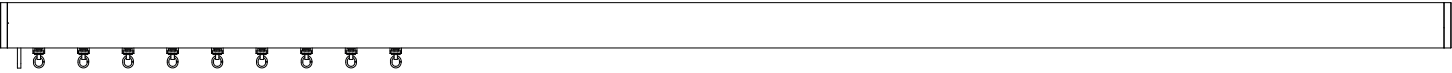

Hand Drawn System - Pair Stack →←

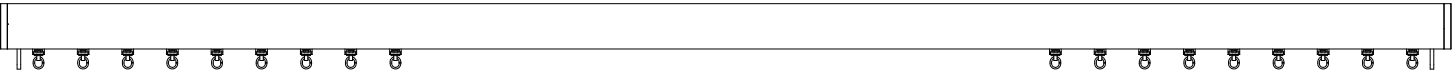

ECLIPSE Coverpole - Hand Drawn • Ø30mm (1³/₁₆"

Finishes

Alabaster • Dusk • Granite • Slate • Flint • Barley • Dove • Millstone • Clay • Cocoa • Cloud • Ceramic • Bone • Cream • Parchment • Damson • Moss • Smoke • Frame Grey • Raven
Coat Options Matte (M) • Satin (S) • Gloss (G) • Platinum • Champagne • Gold • Cognac • Gunmetal • Antique Brass • Pewter • Bronzed
Coat Options Satin (S) • Gloss (G)
Progressive (Additional to above) Brushed Stainless • Brushed Brass Tint • Brushed Bronze Tint • Brushed Carbon Tint
Classic (Additional to above) Polished • Natural Steel • Brass Toned • Matte Brass Toned • Oil Rubbed • Waxed

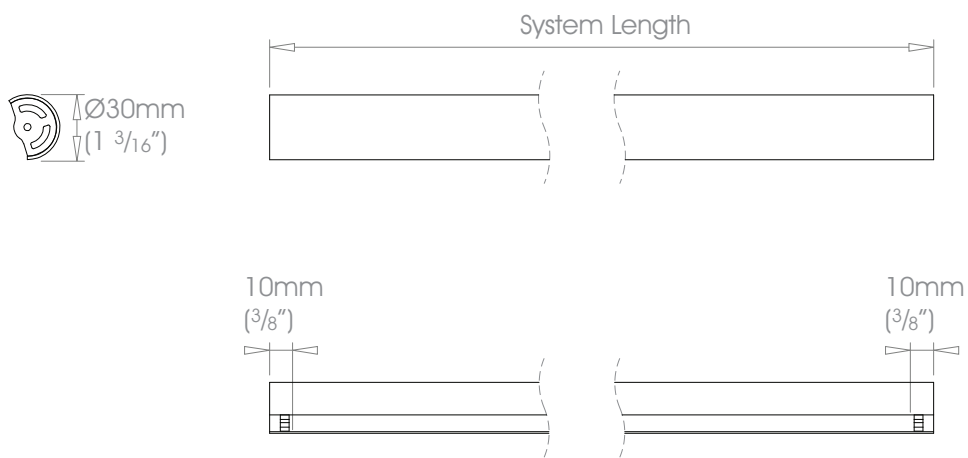

30mm (1 3/16") Coverpole

ECLIPSE Coverpole - Hand Drawn • Ø38mm (1 1/2")

Finishes

Alabaster • Dusk • Granite • Slate • Flint • Barley • Dove • Millstone • Clay • Cocoa • Cloud • Ceramic • Bone • Cream • Parchment • Damson • Moss • Smoke • Frame Grey • Raven
Coat Options Matte (M) • Satin (S) • Gloss (G) • Platinum • Champagne • Gold • Cognac • Gunmetal • Antique Brass • Pewter • Bronzed
Coat Options Satin (S) • Gloss (G)
Progressive (Additional to above) Brushed Stainless • Brushed Brass Tint • Brushed Bronze Tint • Brushed Carbon Tint
Classic (Additional to above) Polished • Natural Steel • Brass Toned • Matte Brass Toned • Oil Rubbed • Waxed

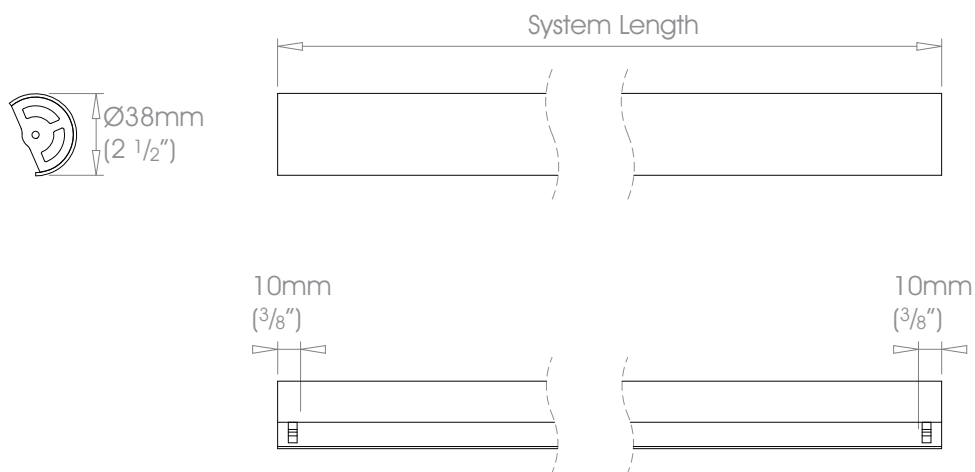

38mm (1 1/2") Coverpole

ECLIPSE Coverpole - Hand Drawn • Ø50mm (2")

Finishes

Alabaster • Dusk • Granite • Slate • Flint • Barley • Dove • Millstone • Clay • Cocoa • Cloud • Ceramic • Bone • Cream • Parchment • Damson • Moss • Smoke • Frame Grey • Raven
Coat Options Matte (M) • Satin (S) • Gloss (G) • Paint on Tulip Wood (T)
 Platinum • Champagne • Gold • Cognac • Gunmetal • Antique Brass • Pewter • Bronzed
Coat Options Satin (S) • Gloss (G)
Progressive (Additional to above) Brushed Stainless • Brushed Brass Tint • Brushed Bronze Tint • Brushed Carbon Tint
Classic (Additional to above) Polished • Natural Steel • Brass Toned • Matte Brass Toned • Oil Rubbed • Waxed
Deco (Additional to above) Aged Brass* • Waxed Brass* • Polished Brass • Aged Oak • Jacobean Oak • Antique Mahogany • Ebony

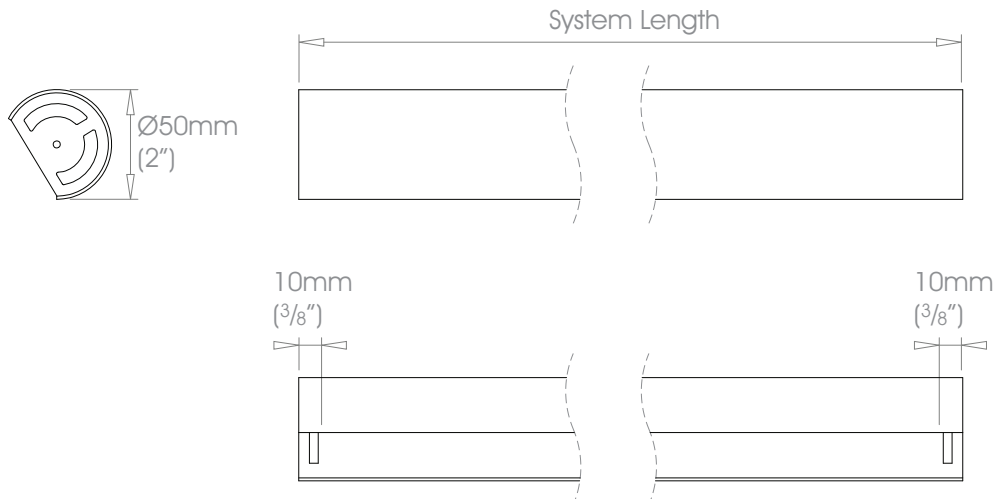

50mm (2") Coverpole

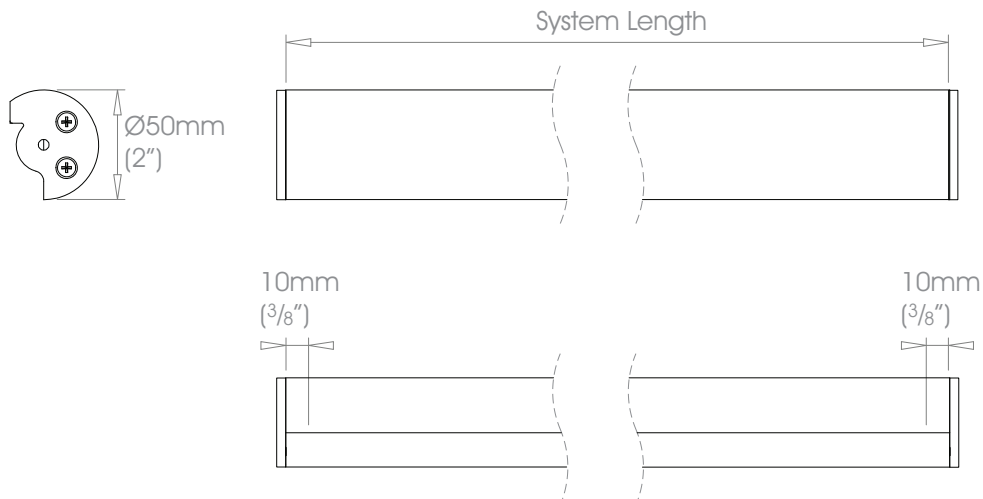

50mm (2") Wood Coverpole

ECLIPSE Hand Drawn • Track

Finishes Track will be finished in a complementary colour to match the cover pole see table on page 7 for details.

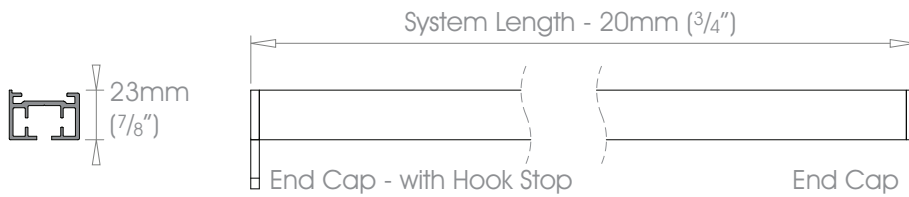



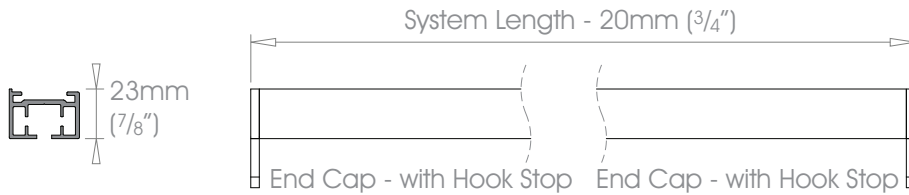

Hand Drawn Track - Single Stack →

-  Gliders Single Stack → up to 3m (10')
-  Wave - Gliders Single Stack → up to 3m (10')
-  Ripplefold - Rollers Single Stack → up to 6m (20')
-  Rollers Single Stack → up to 6m (20')
-  Wave - Rollers Single Stack → up to 6m (20')



Hand Drawn Track - Pair Stack →←

-  Gliders Pair Stack →← up to 6m (20')
-  Wave - Gliders Pair Stack →← up to 6m (20')
-  Ripplefold - Rollers Pair Stack →← up to 6m (20')
-  Rollers Pair Stack →← up to 6m (20')
-  Wave - Rollers Pair Stack →← up to 6m (20')

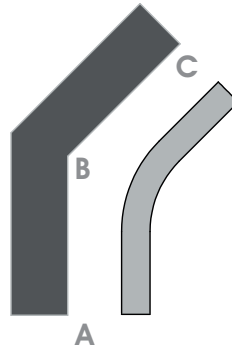

Minimum wall sizes and projections Based on 135° bend angles

Diameter	Wall A - B	Wall B - C	Minimum coverpole bend radius	Minimum internal track bend radius	Minimum projection
38mm (1 1/2")	300mm (11 13/16")	300mm (11 13/16")	254mm (10")	275mm (10 13/16")	100mm (4")
50mm (2")	300mm (11 13/16")	300mm (11 13/16")	254mm (10")	275mm (10 13/16")	100mm (4")

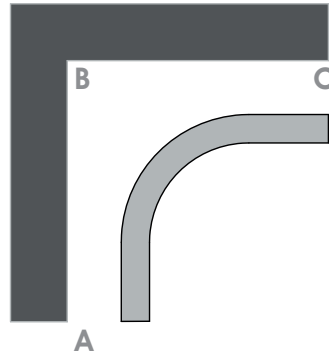

Minimum wall sizes and projections Based on 90° bend angles

Diameter	Wall A - B	Wall B - C	Minimum coverpole bend radius	Minimum internal track bend radius	Minimum projection
38mm (1 1/2")	500mm (19 11/16")	500mm (19 11/16")	254mm (10")	275mm (10 13/16")	100mm (4")
50mm (2")	500mm (19 11/16")	500mm (19 11/16")	254mm (10")	275mm (10 13/16")	100mm (4")

Please note, return bends & continuous curves are not available.

ECLIPSE Hand Drawn • Coverpole + Track Bay Bends

Finishes

Alabaster • Dusk • Granite • Slate • Flint • Barley • Dove • Millstone • Clay • Cocoa • Cloud • Ceramic • Bone • Cream • Parchment • Damson • Moss • Smoke • Frame Grey • Raven
Coat Options Matte (M) • Satin (S) • Gloss (G) • Paint on Tulip Wood (T)
 Platinum • Champagne • Gold • Cognac • Gunmetal • Antique Brass • Pewter • Bronzed
Coat Options Satin (S) • Gloss (G)
Progressive (Additional to above) Brushed Stainless • Brushed Brass Tint • Brushed Bronze Tint • Brushed Carbon Tint
Classic (Additional to above) Polished • Natural Steel • Brass Toned • Matte Brass Toned • Oil Rubbed • Waxed
Deco (Additional to above) Aged Brass* • Waxed Brass* • Polished Brass • Aged Oak • Jacobean Oak • Antique Mahogany • Ebony

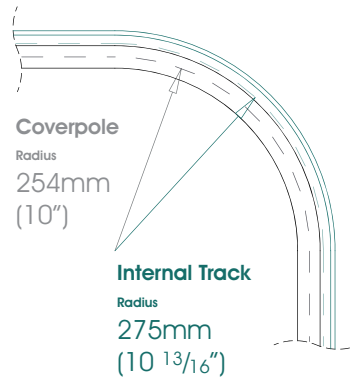

30mm (1 3/16") Not Available

38mm (1 1/2") Coverpole + Track Bay Bend

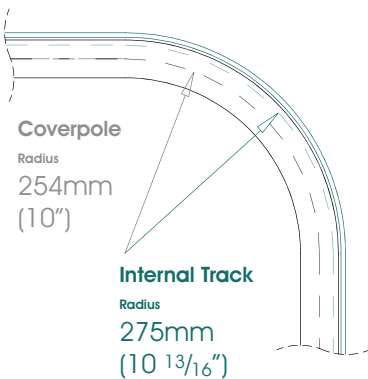

50mm (2") Coverpole + Track Bay Bend

Please note return bends are not available

ECLIPSE Curtain Information • Drops - $\varnothing 30\text{mm}$ (1 3/16") - Hand Drawn Systems

The information below shows the relationship between the coverpole, track, brackets and gliders/rollers. This will enable the correlation between pole heights and curtain drops to be easily calculated. Bracket projection measurements are from the back wall the centre of the track and are a good indicator of where the curtain will fall. The coverpole sits 19mm (3/4") in-front of track centre. Ceiling bracket drop measurements are from the ceiling to the top of the pole.

Single System - $\varnothing 30\text{mm}$ (1 3/16") Coverpole

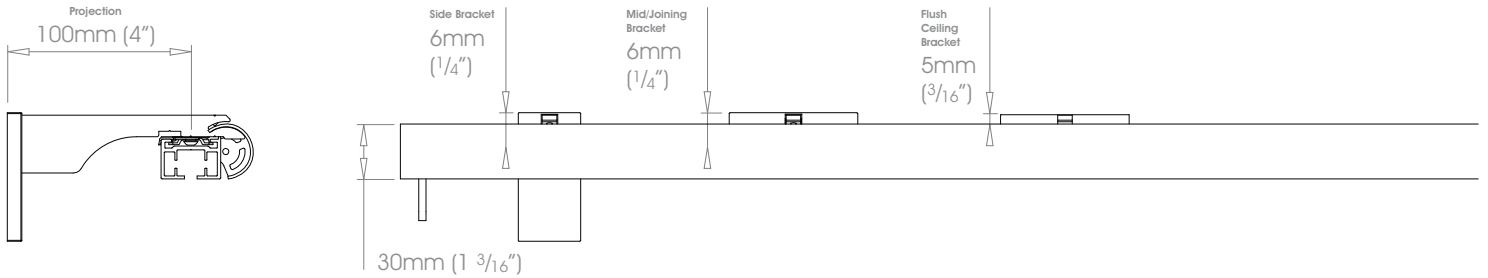

Pin Hook Measurement

From bottom of the track

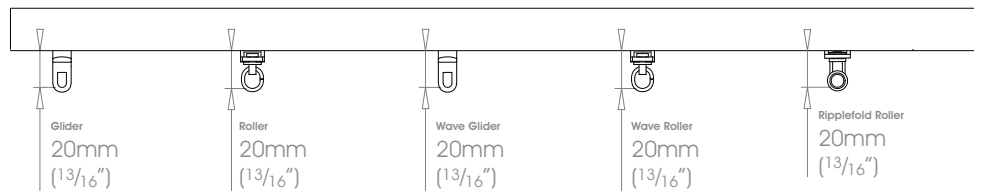

ECLIPSE Curtain Information • Drops - $\varnothing 38\text{mm}$ (1 1/2") - Hand Drawn Systems

The information below shows the relationship between the $\varnothing 38\text{mm}$ (1 1/2") coverpole, track, brackets and gliders/rollers. This will enable the correlation between pole heights and curtain drops to be easily calculated. Bracket projection measurements are from the back wall the centre of the track and are a good indicator of where the curtain will fall. The coverpole sits 19mm (3/4") in-front of track centre. Ceiling bracket drop measurements are from the ceiling to the top of the pole.

Single System - $\varnothing 38\text{mm}$ (1 1/2") Coverpole

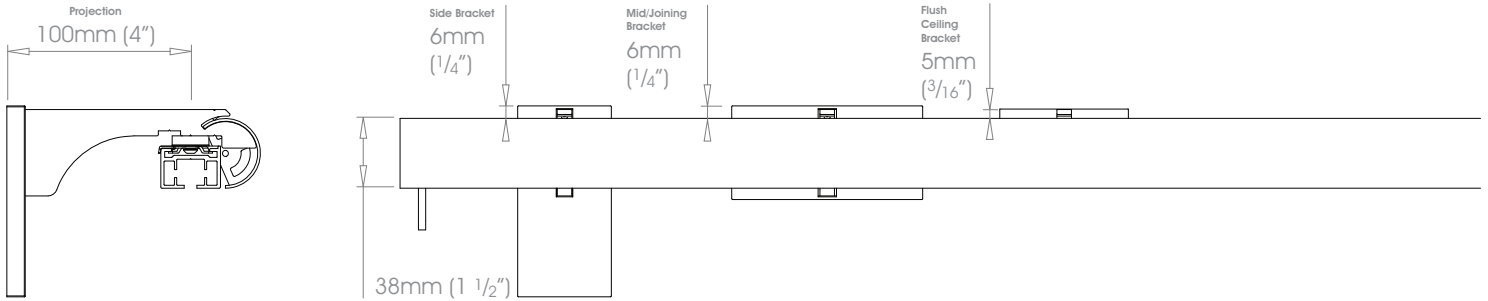

Double System - Front $\varnothing 38\text{mm}$ (1 1/2") Coverpole + Back $\varnothing 30\text{mm}$ (1 3/16") Coverpole

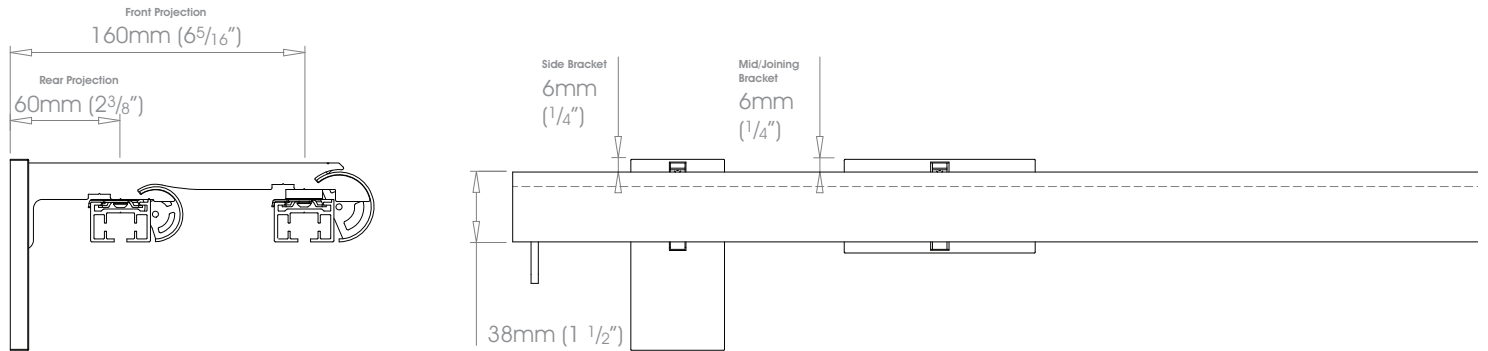

Pin Hook Measurement

From bottom of the track

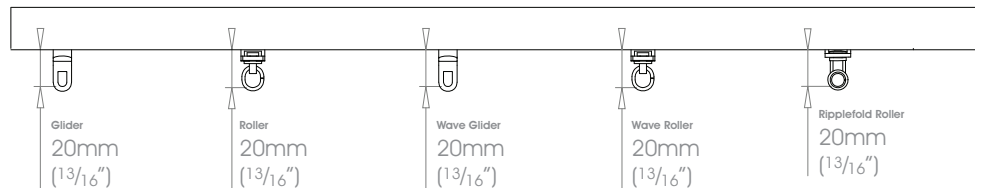

ECLIPSE Curtain Information • Drops - $\varnothing 50\text{mm}$ (2") - Hand Drawn Systems

The information below shows the relationship between the $\varnothing 50\text{mm}$ (2") coverpole, track, brackets and gliders/rollers. This will enable the correlation between pole heights and curtain drops to be easily calculated. Bracket projection measurements are from the back wall the centre of the track and are a good indicator of where the curtain will fall. The coverpole sits 19mm ($3/4$ ") in-front of track centre. Ceiling bracket drop measurements are from the ceiling to the top of the pole.

Single System - $\varnothing 50\text{mm}$ (2") Coverpole

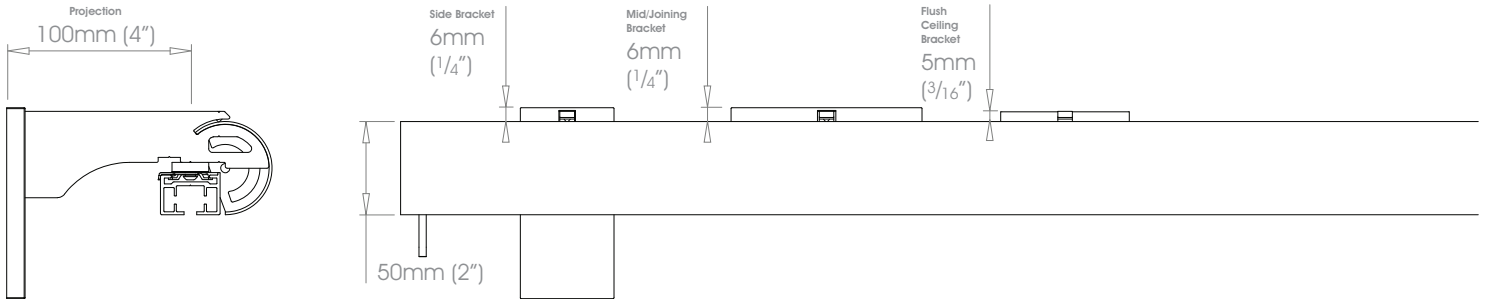

Double System - Front $\varnothing 50\text{mm}$ (2") Coverpole + Back $\varnothing 38\text{mm}$ (1 1/2") Coverpole

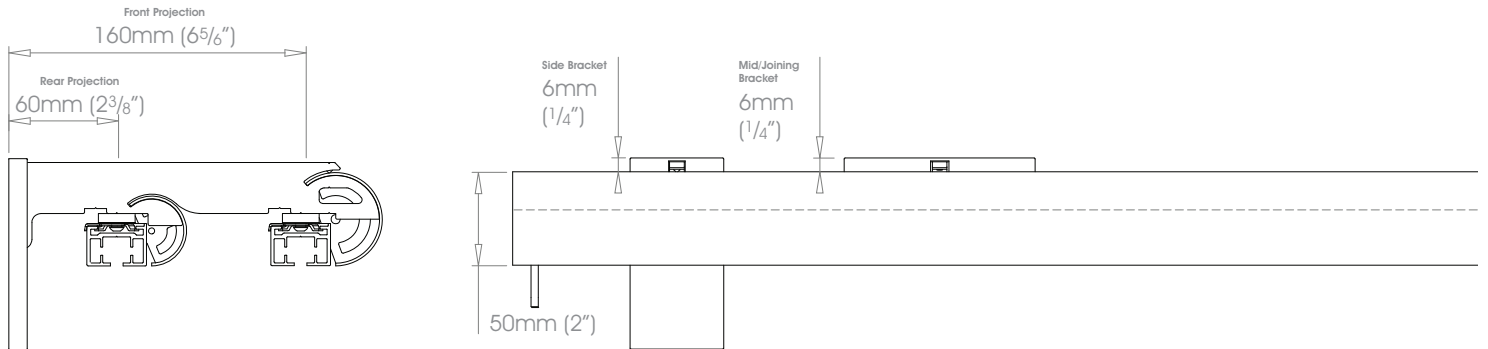

Pin Hook Measurement

From bottom of the track

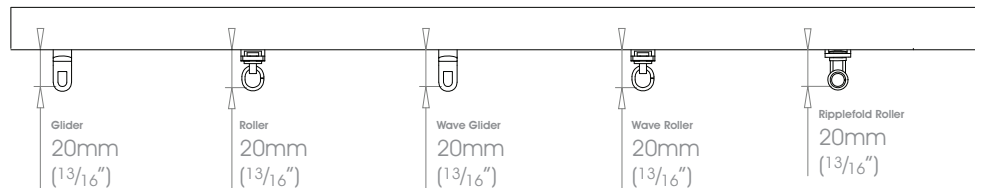

Stacking

This is the area where the curtains hang against the wall when they are pulled open, by covering the wall and not the glass, during the day, it allows more light into the room.

Allow 30% of the length of the track for curtain stacking, very full curtains (e.g. pencil pleat) will need more space than flatter ones, lined and interlined curtains will also require more stacking space than unlined.

Overlap arms are not supplied with hand drawn systems as curtains on these systems are intended to make a butt join, if overlap arms are specified as a special option an additional 100mm (4") needs to be added to the curtain widths and this in turn will be added to the stack back size.

Stacking Options

With hand drawn systems stacking options are configured at the point of assembly, so must be specified when ordering.

Single or pair stack Wave curtain stacking must be specified when ordering as this will affect the number of gliders/rollers installed into the pole.

Single stack →



Pair stack →←



ECLIPSE Curtain Information • Headings - Standard

Standard headings have variable fullness but an average of 1.5 x pole width can be expected. Pinch pleats are created by several methods (hand sewn, automatic pleating tape, metal 4-prong hooks). Average fullness is around 2.0 x pole width. When properly pleated up, pencil pleat headings can use up to 2.5 x pole width from heavy curtains and as much as 3.0 x pole width for nets.

Standard Fullness 1.5

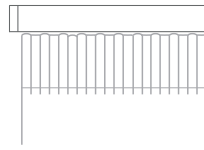

Pinch Pleat Fullness 2.0

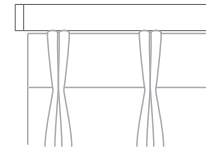

Pencil Pleat Fullness 3.0
(not recommended)

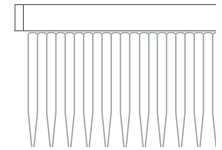

It should be noted that from an efficiency point of view standard headings and pinch pleats are greatly to be preferred. Pencil pleats stack back with much greater difficulty and cause friction.

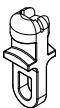

gliders are suitable for most installations. one glider is specified for every 100mm (4").

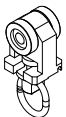

rollers are preferred for heavy drapery. one roller is specified for every 100mm (4").

Curtain Weights

Different types of fabric have widely differing weights. The type of curtain heading used (see below) will determine the fullness of the fabric used; this can be anything from 1.5 x the width of the pole to 3.0 x pole width.

The chart below assumes 100% fullness (2.0 x width of the pole) the weights are very approx and can vary for many reasons. Always check the expected and final total curtain weight with the curtain maker. based on 1200mm (48") fabric width

Curtain Type	Width↓ /Drop→	1m (3.5')	2m (7')	3m (10.5')	4m (14')	5m (16.5')	6m (20')
Print Cotton (Light)	1m (3.5')	0.8kg (1.8lb)	1.7kg (3.7lb)	2.5kg (5.5lb)	3.4kg (7.4lb)	4.2kg (9.2lb)	5.0kg (11.1lb)
	2m (7')	1.3kg (2.8lb)	2.5kg (5.5lb)	3.8kg (8.3lb)	5kg (11.1lb)	6.3kg (13.9lb)	7.6kg (16.6lb)
	3m (10')	1.7kg (3.7lb)	3.4kg (7.4lb)	5kg (11.1lb)	6.7kg (14.8lb)	8.4kg (18.5lb)	10kg (22lb)
Linen (Medium)	1m (3.5')	1.1kg (2.3lb)	2.1kg (4.6lb)	3.2kg (6.9lb)	4.2kg (9.2lb)	5.3kg (11.6lb)	6.3kg (13.9lb)
	2m (7')	1.6kg (3.5lb)	3.2kg (6.9lb)	4.7kg (10.4lb)	6.3kg (13.9lb)	7.9kg (17.3lb)	9.5kg (20.8lb)
	3m (10')	2.1kg (4.6lb)	4.2kg (9.2lb)	6.3kg (13.9lb)	8.4kg (18.5lb)	10.5kg (23.1lb)	12.6kg (27.7lb)
Velvet (Heavy)	1m (3.5')	1.5kg (3.2lb)	3.2kg (6.5lb)	4.4kg (9.7lb)	5.9kg (12.9lb)	7.4kg (16.2lb)	8.8kg (19.4lb)
	2m (7')	2.2kg (4.9lb)	4.4kg (9.7lb)	6.7kg (12.6lb)	8.8kg (19.4lb)	11kg (24.3lb)	13.2kg (22lb)
	3m (10')	2.9kg (6.5lb)	5.9kg (12.9lb)	8.8kg (19.4lb)	11.8kg (26lb)	14.7kg (32.2lb)	17.6kg (39lb)

ECLIPSE Curtain Information • Headings - Wave®

Wave is a simple **S** folded heading system consisting of gliders spaced by a cord and a special pocketed header tape that is sewn onto a flat panel curtain. When assembled in the pole, the gliders/rollers on the cord are spaced at spacings shown below and this fixes the 'pitch' of the Wave. The flat panel curtain(s) are made in the conventional way with the pocketed Wave header tape sewn to the header. Hooks are fitted to header tape at a set spacing creating the Wave effect

Wave®

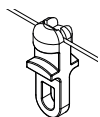
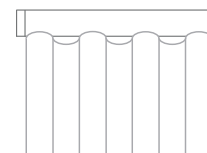

Wave® gliders

80mm (3 1/8") spacing between the gliders.

Glider-Cord Spacing	Curtain Hook Spacing	Approx. Curtain Fullness	Stack Depth	Min Bracket Projection
80mm (3 1/8")	160mm (6 5/16")	2.3	180mm (7 1/16") per 1M (39 3/8") of pole	100mm (4")

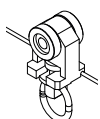

Wave® rollers

80mm (3 1/8") spacing between the rollers

Roller-Cord Spacing	Curtain Hook Spacing	Approx. Curtain Fullness	Stack Depth	Min Bracket Projection
80mm (3 1/8")	160mm (6 5/16")	2.3	180mm (7 1/16") per 1M (39 3/8") of pole	100mm (4")

Fabric suitability

There is no standard test that will indicate whether a fabric is suitable for Wave. However, experience suggests it is normally suitable for:

- Voiles
- Lined cotton
- Interlined Silk
- Blackout lining

The soft curves of Wave do not lend themselves to: - stiff fabrics

- Heavy embroidery
- Irregular vertical stripes
- Metallic threads

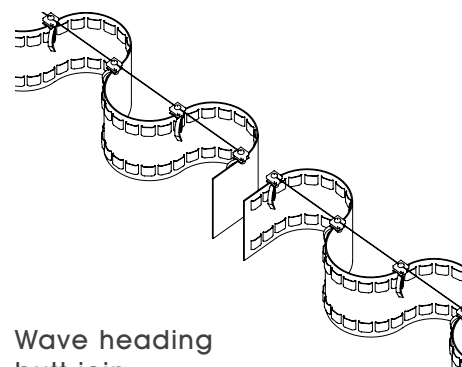

Wave heading
butt join

ECLIPSE Accessories • Draw Rod - Fine

Finishes

Alabaster • Dusk • Granite • Slate • Flint • Barley • Dove • Millstone • Clay • Cocoa • Cloud • Ceramic • Bone • Cream • Parchment • Damson • Moss • Smoke • Frame Grey • Raven **Coat Options** Matte (M) • Satin (S) • Gloss (G) • Platinum • Champagne • Gold • Cognac • Gunmetal • Antique Brass • Pewter • Bronzed **Coat Options** Satin (S) • Gloss (G)

Progressive (Additional to above) Brushed Stainless • Brushed Brass Tint • Brushed Bronze Tint • Brushed Carbon Tint

Classic (Additional to above) Polished • Natural Steel • Brass Toned • Matte Brass Toned • Oil Rubbed • Waxed

Deco (Additional to above) Aged Brass* • Waxed Brass* • Polished Brass* • Polished Nickel - Can be specified at twice the cost of the standard finish

* Will be finished in a complementary finish



Draw rods are supplied with a draw rod carrier, this can be installed into the track at the clients discretion. Alternatively the draw rod can be attached directly to the glider/roller.

This item can be used in conjunction with the wave brake.

Draw Rod - Fine

 Weight 400g (14oz)

ECLIPSE Accessories • Draw Rod - Standard

Finishes

Alabaster • Dusk • Granite • Slate • Flint • Barley • Dove • Millstone • Clay • Cocoa • Cloud • Ceramic • Bone • Cream • Parchment • Damson • Moss • Smoke • Frame Grey • Raven **Coat Options** Matte (M) • Satin (S) • Gloss (G) Platinum • Champagne • Gold • Cognac • Gunmetal • Antique Brass • Pewter • Bronzed **Coat Options** Satin (S) • Gloss (G)

Progressive (Additional to above) Brushed Stainless • Brushed Brass Tint • Brushed Bronze Tint • Brushed Carbon Tint

Classic (Additional to above) Polished • Natural Steel • Brass Toned • Matte Brass Toned • Oil Rubbed • Waxed

Deco (Additional to above) Aged Brass* • Waxed Brass* • Polished Brass* • Polished Nickel - Can be specified at twice the cost of the standard finish

* Will be finished in a complementary finish



Draw rods are supplied with a draw rod carrier, this can be installed into the track at the clients discretion. Alternatively the draw rod can be attached directly to the glider/roller.

This item can be used in conjunction with the wave brake.

Draw Rod - Standard

 Weight 439g (15.5oz)



CONTACT

Web www.bradleycollection.com

Email info@bradleycollection.com

Follow     

WORLD

The Bradley Collection Ltd
Lion Barn • Maitland Road
Needham Market • Suffolk
IP6 8NS • UK

Telephone +44 (0)1449 722 724

Fax +44 (0)1449 722 728

USA & Canada

The Bradley Collection Inc.
3625 Hayden Avenue, Suite E
Culver City • CA • 90232 • USA

Telephone +1 (310) 815 8255

Fax +1 (310) 815 9255

Specialised fixings for mounting brackets will be required in certain situations and are not provided as standard.
Steel items are not recommended for damp conditions such as shower rooms.
Crystal finials and acrylic poles should not be positioned in direct sunlight, and are not suitable for use in conservatories.
Brass items are supplied unacquered and will tarnish over time.

The Bradley Collection reserves the right to modify design and materials without prior notice as part of a process of continual product improvement. Due to printing limitations, colours in this brochure may not be accurate.

Products are protected by Design Rights, under provisions of Copyright, Designs & Patents Act 1988.

Bradley®, The Bradley Collection® and  Logo are registered Community trademarks of The Bradley Collection Ltd. in Europe and registered trademarks of the Bradley Collection, Inc. in the USA.

Published: 0920 • Copyright © The Bradley Collection Ltd. 2020