

ELYSIAN

THE **BRADLEY**
COLLECTION

SPECIFICATION GUIDE

ELYSIAN

SPECIFICATION GUIDE

This specification guide was designed to outline the main considerations that need to be made when quoting or ordering a system.

If any questions arise please call your local sales representative or contact The Bradley Collection directly.

System Information Page 3-11

POLES Page 4

JOINING & BAYS Page 5

MINIMUM WALL SIZES Page 6

BRACKET ALIGNMENT Page 7

PASSING SYSTEM Page 8

CUSTOM BRACKETS Page 9

CURTAIN DROPS Page 10-11

Finishes Page 12-15

Finials Page 16-28

Poles Page 29-32

Brackets Page 33-45

Rings Page 46-48

Accessories Page 49-53

**THE BRADLEY
COLLECTION**

Poles are cut, bent and curved to suit individual requirements. When calculating the length of your pole, remember to allow tolerance beyond the width of the frame for the curtains to draw back to the edge of the window.

Poles exceeding the recommended maximum distance between brackets, will be cut into equal parts unless otherwise specified.

Pole joiners will be supplied.

Pole diameter's - Ø30mm (1³/₁₆") • 38mm (1¹/₂") • 50mm (2")

The overall pole cost is rounded up in 300mm (1ft) increments.

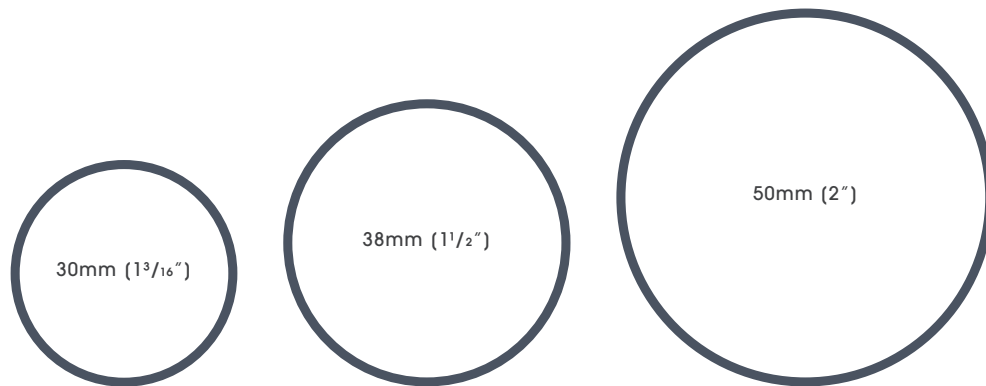

Size	Recommended curtain type for pole diameter	Maximum distance between brackets	Maximum length in one piece	Standard Bend radius
Ø30mm (1 ³ / ₁₆ ")	Medium weight, lined & interlined curtains	2100mm (83")	4000mm (157") ⊕	⊖255mm (10")
Ø38mm (1 ¹ / ₂ ")	Medium to heavy weight, lined & interlined curtains	2200mm (87")	4000mm (157") ⊕	⊖255mm (10")
Ø50mm (2")	Heavy weight interlined curtains	2400mm (96")	4000mm (157") ⊕	⊖255mm (10")

⊕ Section lengths over 2.4m (94") will incur a handling charge

PROVIDING POLE LENGTHS

Pole lengths can be specified in two ways.

OPTION A is our preferred method. This covers Pole length only. **OPTION B** combines pole and finial lengths.

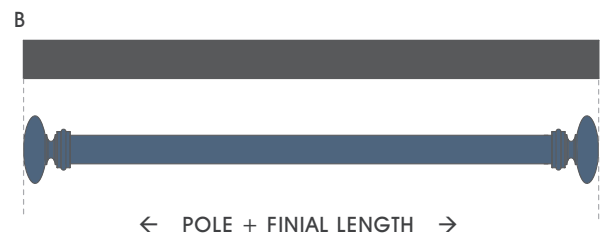
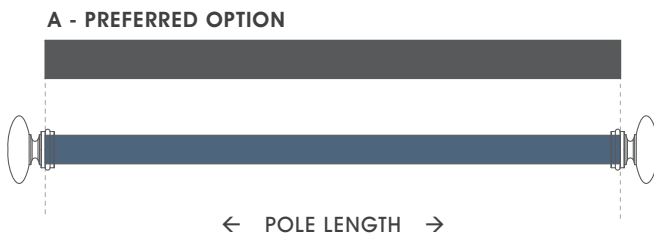

*Section lengths over 2.4m (94") will incur a handling charge

JOINING POLES

Joins must always be supported by a bracket.



BESPOKE BAYS

Bradley's bespoke service allows poles to be specifically made for unique bay windows and complex long span installations. Poles can be shaped to create a system that follows contours. Passing rings have been designed to traverse over brackets and around bends. Using a double pole system in a bay window can create an elegant as well as practical treatment.



One Bend Bay



Two Bend Bay



Square Bay



Four Bend Bay



Continuous Curve

BRADLEY BAY CHECKER +

Bay Checker + is part of our Digital Toolbox, allowing you to check your measurement for bays and curves whilst onsite, as well as storing straight window dimensions for your projects.

Unlimited measurements may be saved locally to your device or shared to your colleagues.

Available as a free download for iOS or Android.

For more information on Bay Checker + and latest enhancements to our Digital Toolbox visit

www.bradleycollection.com/digital-toolbox/

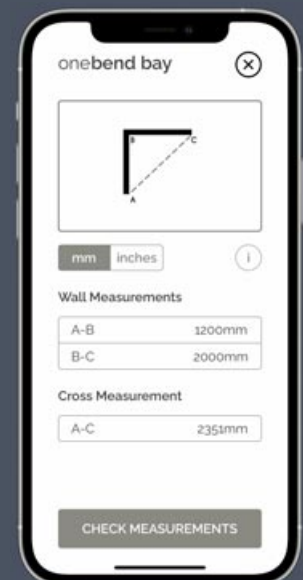

The table below is a guide for the minimum wall size required to fit a bend into the space.

Standard bend radius shown is the minimum radius achievable.

Projection shown for return bends, is the minimum requirement to clear the corner at point A.

Note: changes in angles and projections will alter the minimum wall sizes required

135° BEND ANGLES

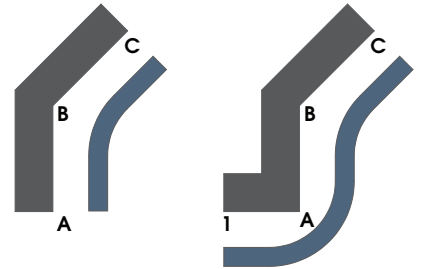

Diameter	Return 1-A	Wall A - B	Wall B - C	Minimum Bend Radius	Minimum Projection
∅30mm (1 ³ / ₁₆ "	n/a	197mm (7 ³ / ₄ "	277mm (10 ⁷ / ₈ "	254mm (10"	100mm (4"
∅30mm (1 ³ / ₁₆ "	115mm (4 ¹ / ₂ "	340mm (13 ³ / ₈ "	277mm (10 ⁷ / ₈ "	254mm (10"	100mm (4"
∅38mm (1 ¹ / ₂ "	n/a	197mm (7 ³ / ₄ "	277mm (10 ⁷ / ₈ "	254mm (10"	100mm (4"
∅38mm (1 ¹ / ₂ "	115mm (4 ¹ / ₂ "	340mm (13 ³ / ₈ "	277mm (10 ⁷ / ₈ "	254mm (10"	100mm (4"
∅50mm (2"	n/a	197mm (7 ³ / ₄ "	277mm (10 ⁷ / ₈ "	254mm (10"	100mm (4"
∅50mm (2"	115mm (4 ¹ / ₂ "	340mm (13 ³ / ₈ "	277mm (10 ⁷ / ₈ "	254mm (10"	100mm (4"

90° BEND ANGLES



Diameter	Return 1-A	Wall A - B	Wall B - C	Minimum Bend Radius	Minimum Projection
∅30mm (1 ³ / ₁₆ "	n/a	404mm (15 ⁷ / ₈ "	484mm (19 ¹ / ₈ "	254mm (10"	100mm (4"
∅30mm (1 ³ / ₁₆ "	154mm (6 ¹ / ₈ "	588mm (23 ¹ / ₈ "	534mm (21"	254mm (10"	150mm (5 ⁷ / ₈ "
∅38mm (1 ¹ / ₂ "	n/a	404mm (15 ⁷ / ₈ "	484mm (19 ¹ / ₈ "	254mm (10"	100mm (4"
∅38mm (1 ¹ / ₂ "	154mm (6 ¹ / ₈ "	588mm (23 ¹ / ₈ "	534mm (21"	254mm (10"	150mm (5 ⁷ / ₈ "
∅50mm (2"	n/a	404mm (15 ⁷ / ₈ "	484mm (19 ¹ / ₈ "	254mm (10"	100mm (4"
∅50mm (2"	154mm (6 ¹ / ₈ "	588mm (23 ¹ / ₈ "	534mm (21"	254mm (10"	150mm (5 ⁷ / ₈ "

The information below shows the relationship between the bracket backplate. this will enable easy alignments during installation.

30mm (1³/₁₆") SINGLE BRACKETS

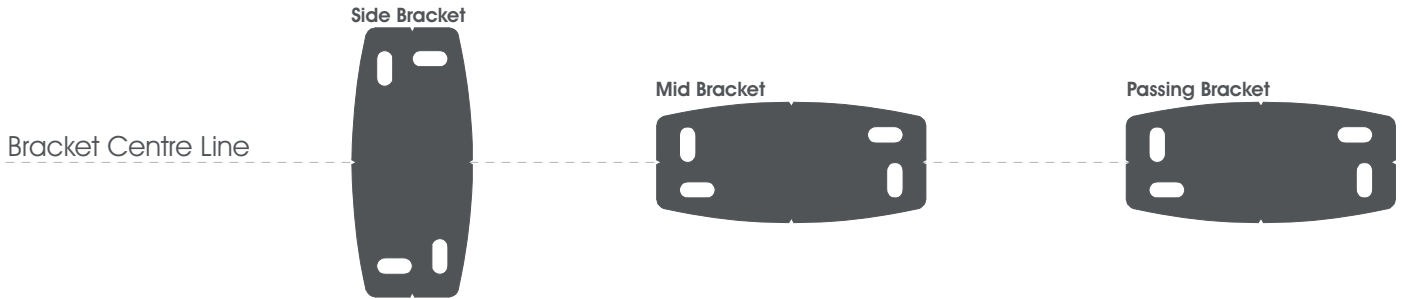

38mm (1¹/₂") • 50mm (2") SINGLE BRACKETS

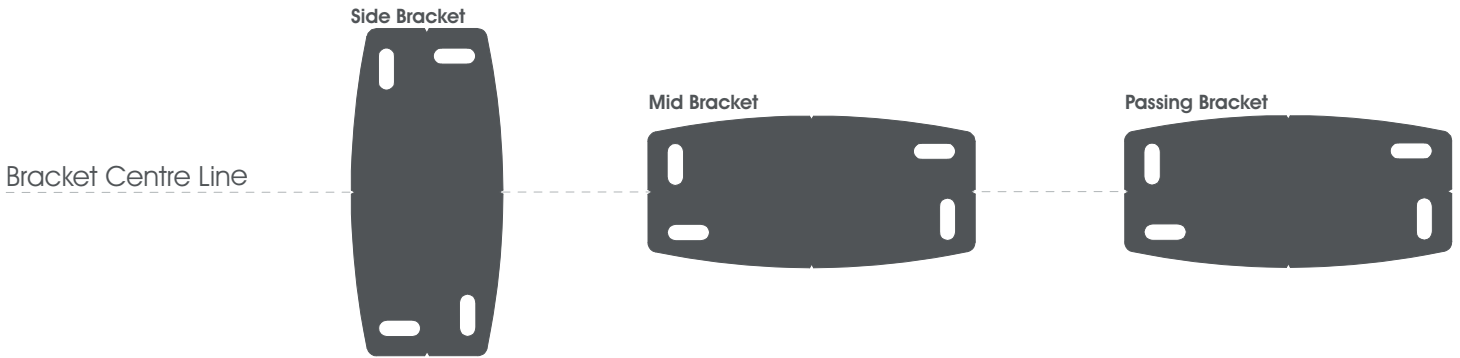

FRONT 38mm (1¹/₂") BACK 30mm (1³/₁₆") • FRONT 50mm (2") BACK 30mm (1³/₁₆") DOUBLE BRACKETS

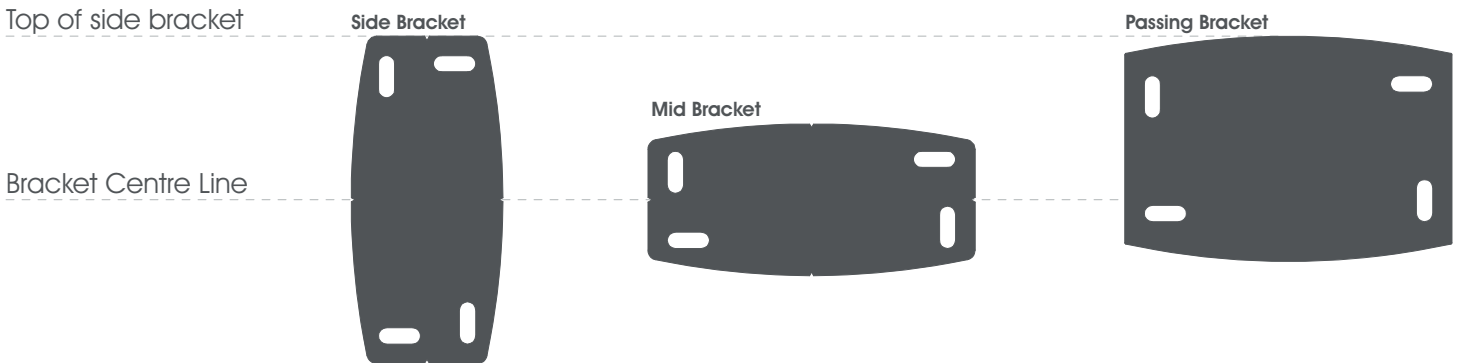

Passing brackets and passing rings allow drapes to traverse around bays and multi-pole systems. passing is available on single pole systems. Passing will only work if the system is correctly installed and the drapes are properly made and attached to the rings.

PASSING GUIDELINES

1. Do make sure the top of the drapery ends underneath the main ring and does not touch or go above the bottom of the ring.
2. Always have the drapery hook perpendicular to the ringlet. Ringlets should not be sewn into a pinch pleat.
3. Be sure to have very little to no puddle on drapery, especially if the fabric is stiff. A stiff header can also cause the rings to not move freely.
4. If using lightweight or sheer fabric, the fabric needs to be weighted enough to pull the rings into the correct passing position.
5. Passing rings are not recommended with draw rods.

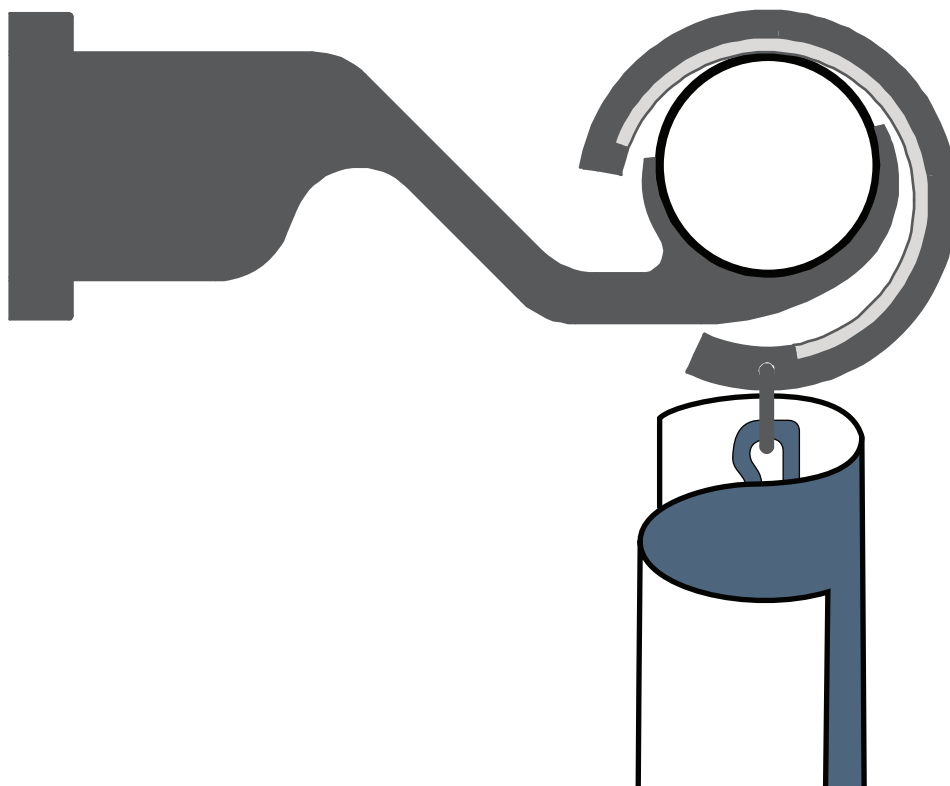

Elysian can be customised to suit virtually any window. For simple projection changes between the Minimums and Maximums listed below brackets are charged at double their standard cost. For all other customisations an additional up-charge and custom fee is applied per drawing



Custom Projection

Specify the exact projection needed.



Custom Fixing Plate

Relevant where space is restricted or weight is a concern.



Uplift

Helps negotiate cornice and similar architectural features.



Angled Brackets

The solution for tight and awkward locations.

MINIMUM & MAXIMUM BRACKET PROJECTIONS

Dimensions outside of these stated min/max projections may still be possible but will generate a design charge per drawing. See Price List for details

Diameter	Type	Standard Projection(s)	Minimum Projection	Maximum Projection
∅30mm (1 ³ / ₁₆ "	Side	100mm (4")	62mm (1 ⁷ / ₁₆ "	200mm (8")
∅30mm (1 ³ / ₁₆ "	Mid	100mm (4")	62mm (1 ⁷ / ₁₆ "	200mm (8")
∅30mm (1 ³ / ₁₆ "	Passing	100mm (4")	81mm (3 ³ / ₁₆ "	200mm (8")
∅30mm (1 ³ / ₁₆ "	Ceiling	100mm (4")	62mm (1 ⁷ / ₁₆ "	200mm (8")
∅30mm (1 ³ / ₁₆ "	Ceiling Passing	100mm (4")	80mm (3 ¹ / ₈ "	200mm (8")
∅38mm (1 ¹ / ₂ "	Side	100mm (4")	76mm (3")	200mm (8")
∅38mm (1 ¹ / ₂ "	Mid	100mm (4")	76mm (3")	200mm (8")
∅38mm (1 ¹ / ₂ "	Passing	100mm (4")	96mm (3 ³ / ₁₆ "	200mm (8")
∅38mm (1 ¹ / ₂ "	Ceiling	100mm (4")	76mm (3")	200mm (8")
∅38mm (1 ¹ / ₂ "	Ceiling Passing	100mm (4")	94mm (3 ³ / ₄ "	200mm (8")
∅50mm (2")	Side	100mm (4")	85mm (3 ³ / ₈ "	200mm (8")
∅50mm (2")	Mid	100mm (4")	85mm (3 ³ / ₈ "	200mm (8")
∅50mm (2")	Passing	100mm (4")	100mm (4")	200mm (8")
∅50mm (2")	Ceiling	100mm (4")	85mm (3 ³ / ₈ "	200mm (8")
∅50mm (2")	Ceiling Passing	100mm (4")	100mm (4")	200mm (8")

The information below shows the relationship between the pole, brackets and rings.
This will enable the correlation between pole heights and curtain drops to be easily calculated.

SINGLE SYSTEM - $\varnothing 30\text{mm}$ ($1\frac{3}{16}$ "

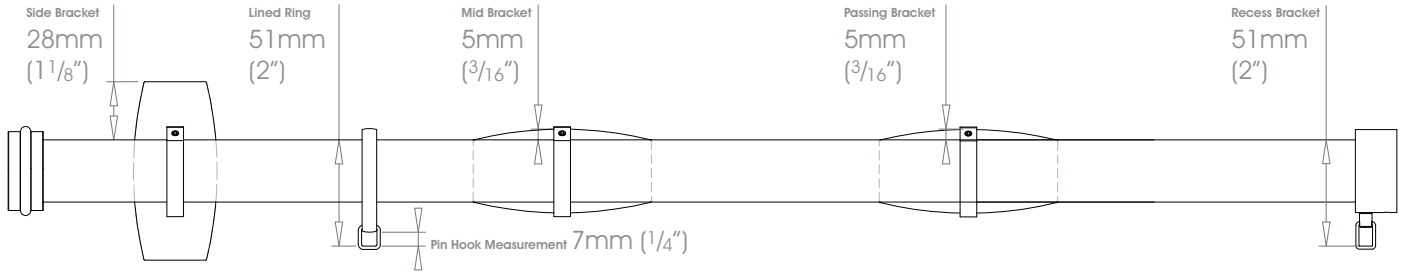

SINGLE SYSTEM - $\varnothing 38\text{mm}$ ($1\frac{1}{2}$ "

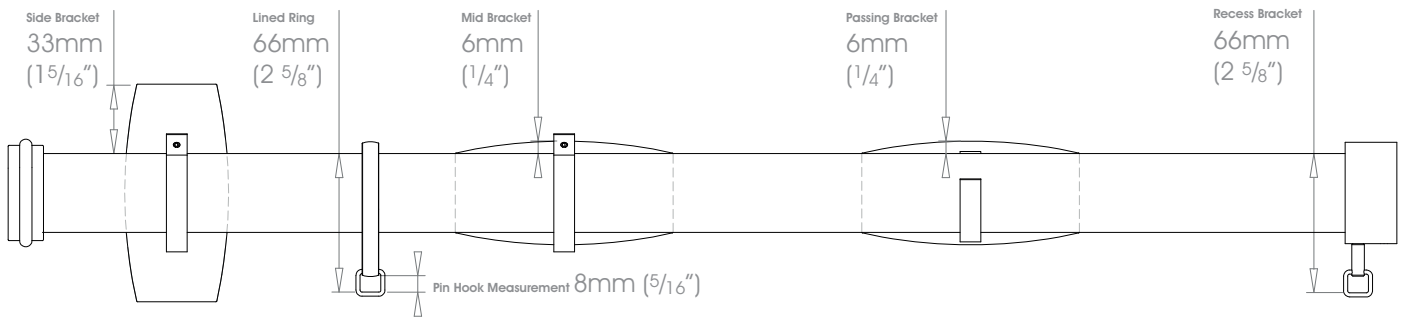

SINGLE SYSTEM - ROUND $\varnothing 50\text{mm}$ (2")

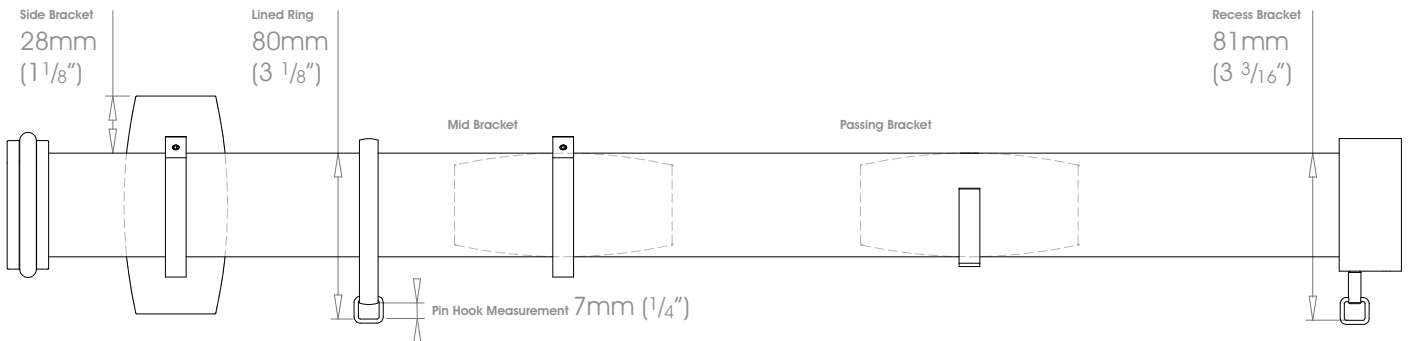

DOUBLE SYSTEM - FRONT $\varnothing 38\text{mm}$ ($1\frac{1}{2}''$) BACK $\varnothing 30\text{mm}$ ($1\frac{3}{16}''$)

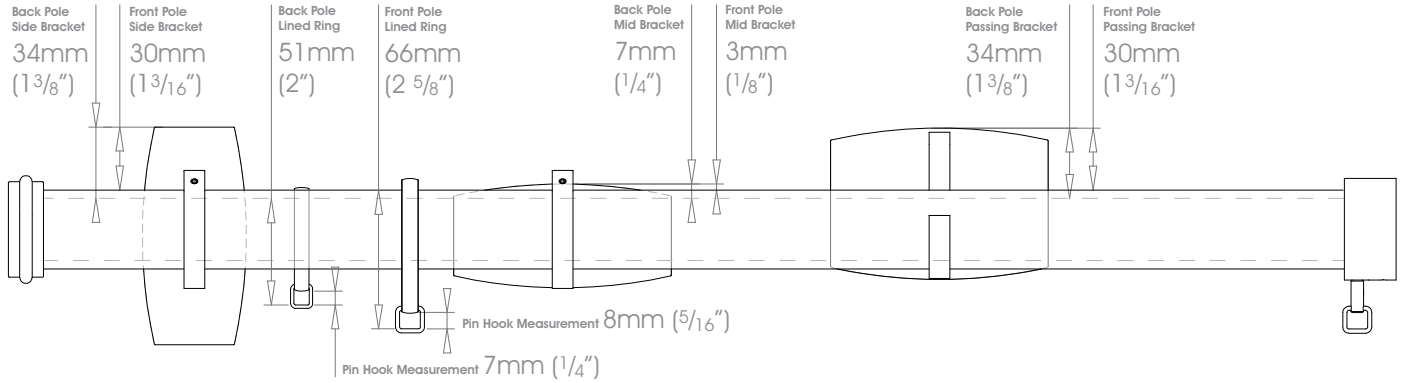

DOUBLE SYSTEM - FRONT $\varnothing 50\text{mm}$ ($2''$) BACK $\varnothing 30\text{mm}$ ($1\frac{3}{16}''$)

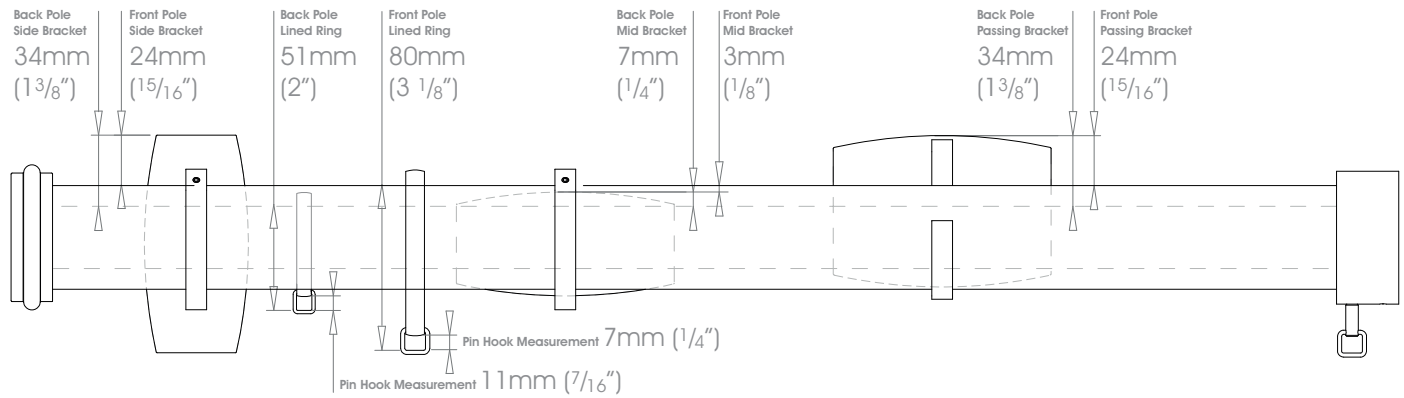

All poles and components may be specified in this stunning palette of colours and finishes, with a choice of coat options throughout.

SHADES

A superb selection of opaque colours, all available in a choice of Matte, Satin or Gloss finish.

COAT OPTIONS

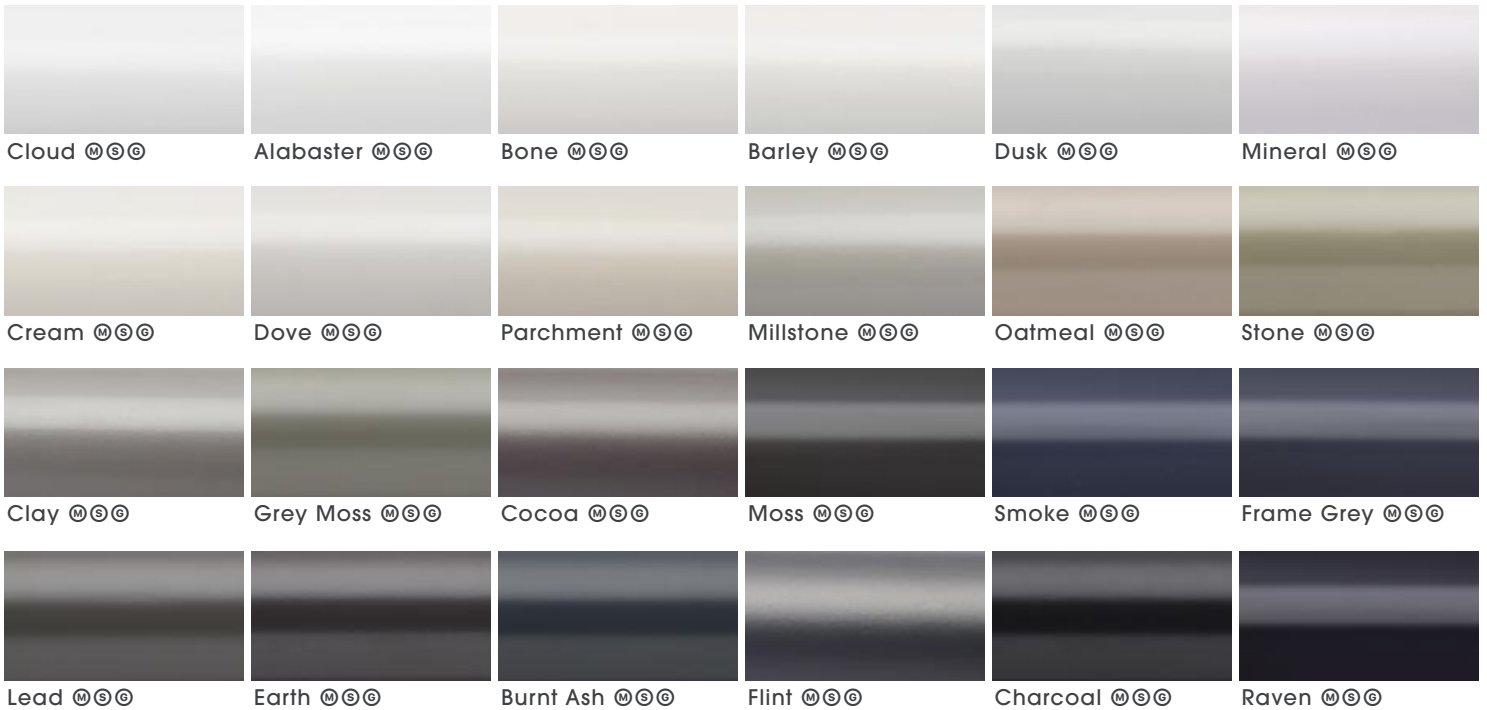

METALLICS

High metallic fleck coatings with most available in Satin and Gloss sheen levels.

COAT OPTIONS

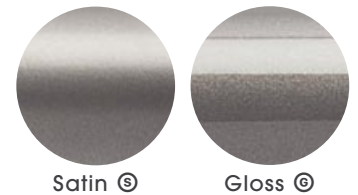

ANODICS

A flat metal colour group, with an anodised style surface texture.

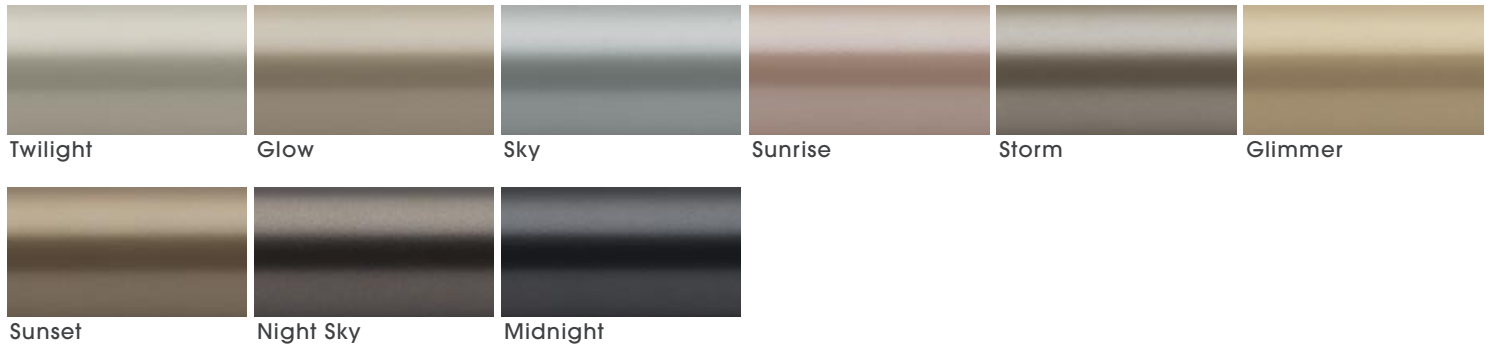

BRIGHTS

Polished plated finishes provide a traditional sense of luxury.



Polished Nickel ☺☺

☺ A finishing charge will apply | ☺ Longer lead-times will apply

CUSTOM FINISHES

Can be specified from RAL K7 finish chart, subject to a per colour upcharge. Which covers up to five poles. See price list for further details



COLOUR MATCHING

A colour matching service is offered, to match your scheme of fittings perfectly . See price list for further details

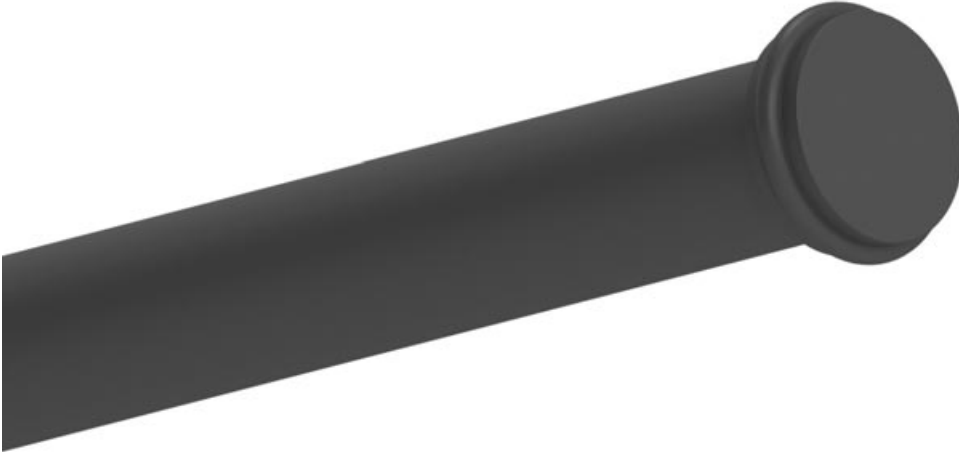

FINISHES **Shades** ☉☉☉ Alabaster • Barley • Bone • Burnt Ash • Charcoal • Clay • Cloud • Cocoa • Cream • Dove • Dusk • Earth • Flint • Frame Grey • Grey Moss
 Lead • Millstone • Mineral • Moss • Oatmeal • Parchment • Raven • Smoke • Stone
Coat Options **Metallics** ☉☉ Antique Brass • Bronzed • Champagne • Cognac • Gold • Gunmetal • Pewter • Platinum
Anodics Glimmer • Glow • Midnight • Night Sky • Sky • Storm • Sunrise • Sunset • Twilight
Brights Can be specified at twice the cost of the standard finish | Polished Nickel
 Matte ☉
 Satin ☉
 Gloss ☉

30mm (1 3/16")

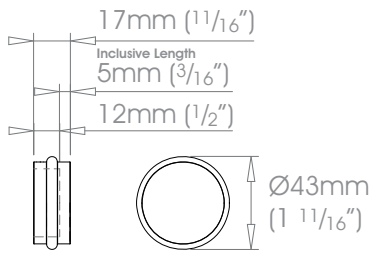

38mm (1 1/2")

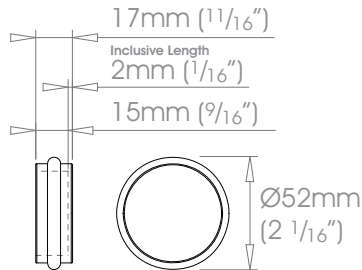

50mm (2")

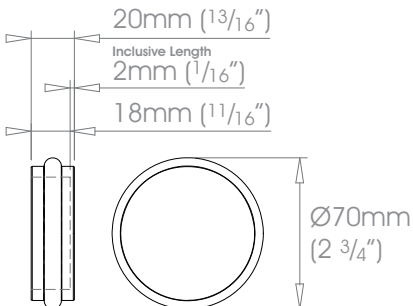



FINISHES **Shades** ☉☉☉ Alabaster • Barley • Bone • Burnt Ash • Charcoal • Clay • Cloud • Cocoa • Cream • Dove • Dusk • Earth • Flint • Frame Grey • Grey Moss
 Lead • Millstone • Mineral • Moss • Oatmeal • Parchment • Raven • Smoke • Stone
Coat Options **Metallics** ☉☉ Antique Brass • Bronzed • Champagne • Cognac • Gold • Gunmetal • Pewter • Platinum
Anodics Glimmer • Glow • Midnight • Night Sky • Sky • Storm • Sunrise • Sunset • Twilight
Brights Can be specified at twice the cost of the standard finish | Polished Nickel
 Matte ☉
 Satin ☉
 Gloss ☉

30mm (1³/₁₆"

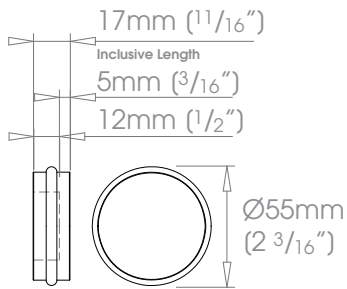

38mm (1¹/₂"

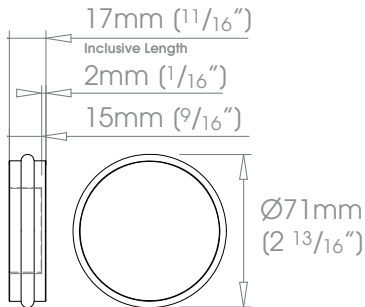

50mm (2"

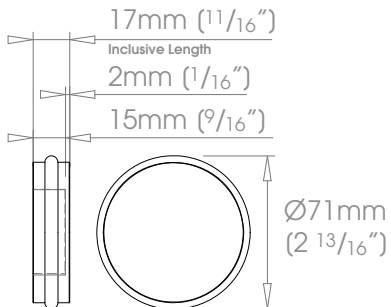



FINISHES Shades ☉☉☉ Alabaster • Barley • Bone • Burnt Ash • Charcoal • Clay • Cloud • Cocoa • Cream • Dove • Dusk • Earth • Flint • Frame Grey • Grey Moss
 Lead • Millstone • Mineral • Moss • Oatmeal • Parchment • Raven • Smoke • Stone
 Coat Options **Metallics** ☉☉ Antique Brass • Bronzed • Champagne • Cognac • Gold • Gunmetal • Pewter • Platinum
Anodics Glimmer • Glow • Midnight • Night Sky • Sky • Storm • Sunrise • Sunset • Twilight
Brights Can be specified at twice the cost of the standard finish | Polished Nickel
 Matte ☉
 Satin ☉
 Gloss ☉

30mm (1 3/16")

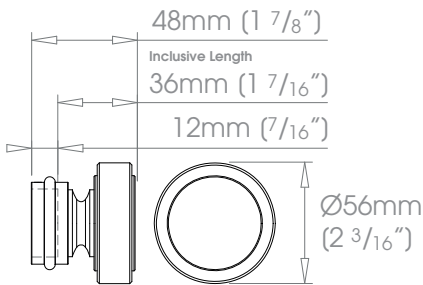

38mm (1 1/2")

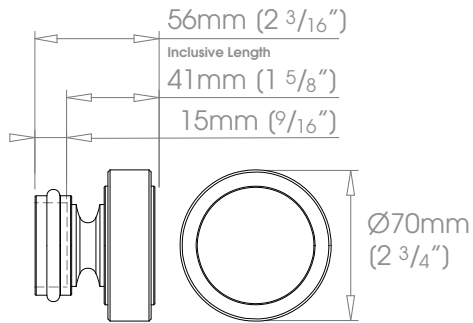

50mm (2")

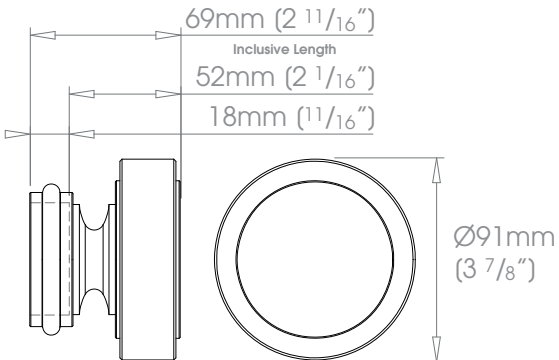



FINISHES Shades @@@ Alabaster • Barley • Bone • Burnt Ash • Charcoal • Clay • Cloud • Cocoa • Cream • Dove • Dusk • Earth • Flint • Frame Grey • Grey Moss
 Lead • Millstone • Mineral • Moss • Oatmeal • Parchment • Raven • Smoke • Stone
 Coat Options **Metallics** @@@ Antique Brass • Bronzed • Champagne • Cognac • Gold • Gunmetal • Pewter • Platinum
Anodics Glimmer • Glow • Midnight • Night Sky • Sky • Storm • Sunrise • Sunset • Twilight
Brights Can be specified at twice the cost of the standard finish | Polished Nickel
 Matte @
 Satin @
 Gloss @

30mm (1 3/16")

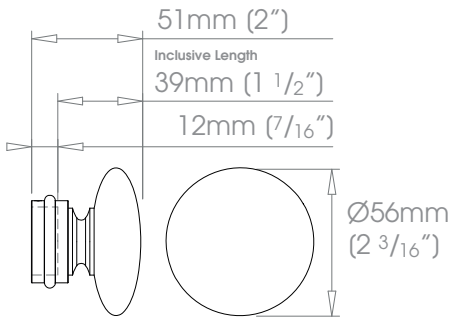

38mm (1 1/2")

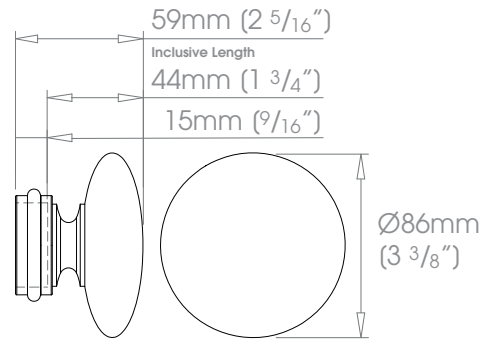

50mm (2")

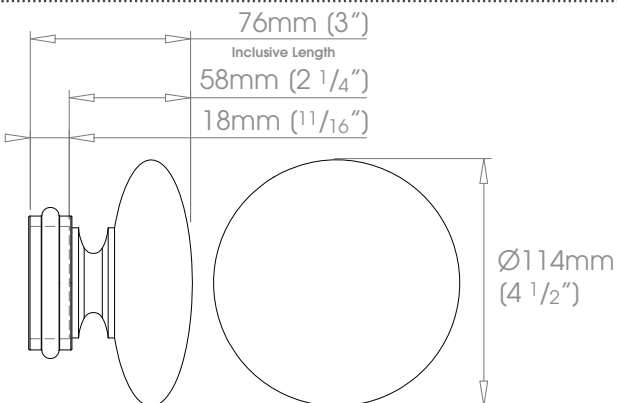



FINISHES Shades ③③③ Alabaster • Barley • Bone • Burnt Ash • Charcoal • Clay • Cloud • Cocoa • Cream • Dove • Dusk • Earth • Flint • Frame Grey • Grey Moss
 Lead • Millstone • Mineral • Moss • Oatmeal • Parchment • Raven • Smoke • Stone
 Coat Options **Metallics** ②② Antique Brass • Bronzed • Champagne • Cognac • Gold • Gunmetal • Pewter • Platinum
Anodics Glimmer • Glow • Midnight • Night Sky • Sky • Storm • Sunrise • Sunset • Twilight
Brights Can be specified at twice the cost of the standard finish | Polished Nickel
 Matte ①
 Satin ②
 Gloss ③

30mm (1 3/16")

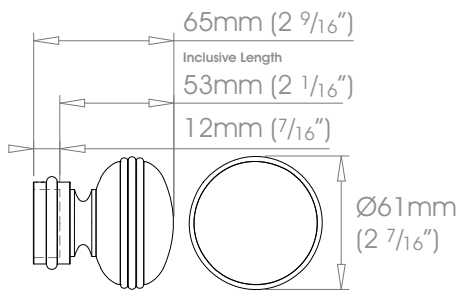

38mm (1 1/2")

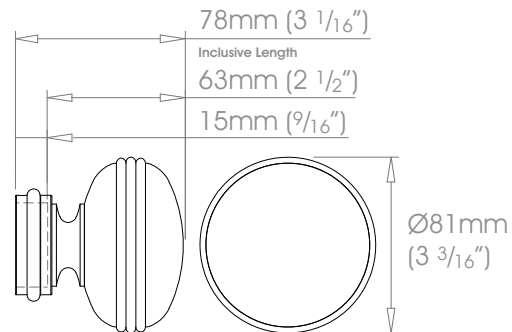

50mm (2")

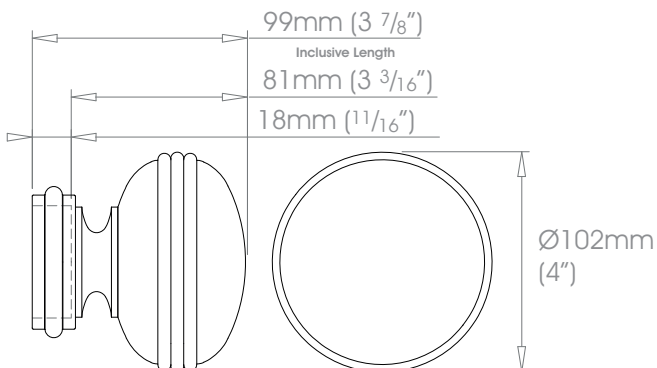



FINISHES Shades ☉☉☉ Alabaster • Barley • Bone • Burnt Ash • Charcoal • Clay • Cloud • Cocoa • Cream • Dove • Dusk • Earth • Flint • Frame Grey • Grey Moss
 Lead • Millstone • Mineral • Moss • Oatmeal • Parchment • Raven • Smoke • Stone
 Coat Options **Metallics** ☉☉ Antique Brass • Bronzed • Champagne • Cognac • Gold • Gunmetal • Pewter • Platinum
Anodics Glimmer • Glow • Midnight • Night Sky • Sky • Storm • Sunrise • Sunset • Twilight
Brights Can be specified at twice the cost of the standard finish | Polished Nickel
 Matte ☉
 Satin ☉
 Gloss ☉

30mm (1 3/16")

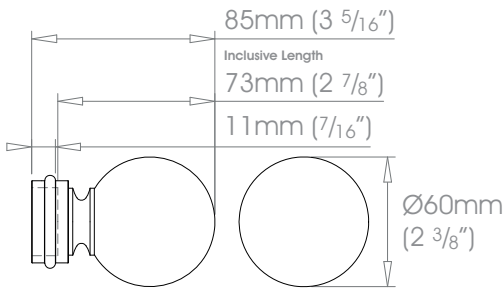

38mm (1 1/2")

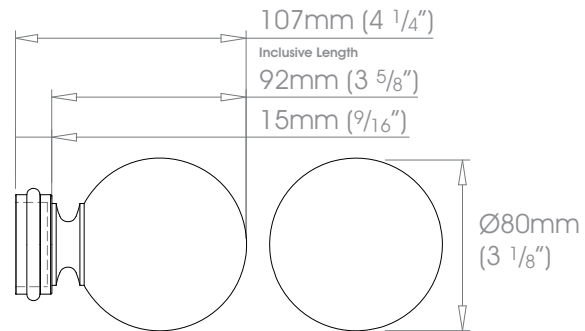

50mm (2")

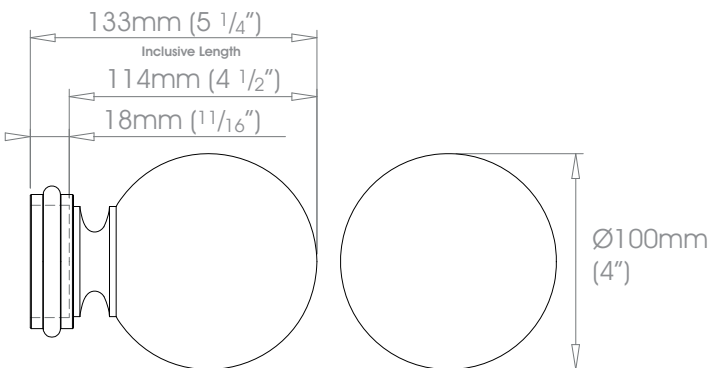



FINISHES Shades ☉☉☉ Alabaster • Barley • Bone • Burnt Ash • Charcoal • Clay • Cloud • Cocoa • Cream • Dove • Dusk • Earth • Flint • Frame Grey • Grey Moss
 Lead • Millstone • Mineral • Moss • Oatmeal • Parchment • Raven • Smoke • Stone
 Coat Options **Metallics** ☉☉ Antique Brass • Bronzed • Champagne • Cognac • Gold • Gunmetal • Pewter • Platinum
Anodics ☉ Glimmer • Glow • Midnight • Night Sky • Sky • Storm • Sunrise • Sunset • Twilight
Brights ☉ Can be specified at twice the cost of the standard finish | Polished Nickel
 Matte ☉
 Satin ☉
 Gloss ☉

30mm (1 3/16")

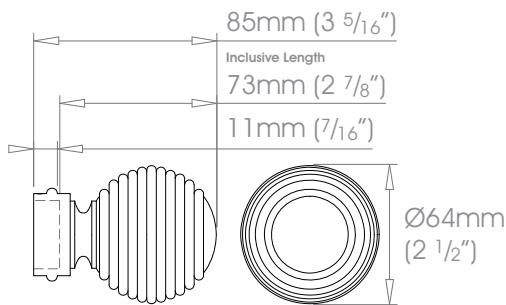

38mm (1 1/2")

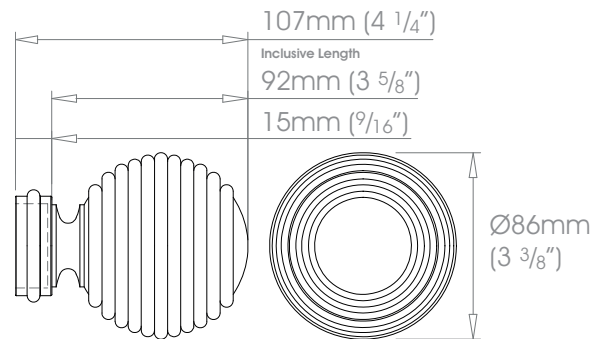

50mm (2")

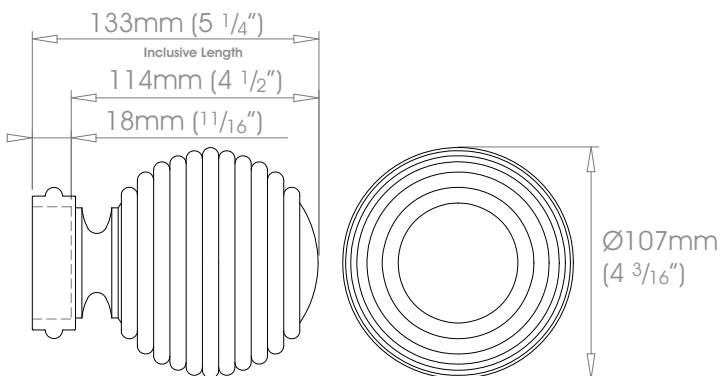



FINISHES **Shades** ☉☉☉ Alabaster • Barley • Bone • Burnt Ash • Charcoal • Clay • Cloud • Cocoa • Cream • Dove • Dusk • Earth • Flint • Frame Grey • Grey Moss • Lead • Millstone • Mineral • Moss • Oatmeal • Parchment • Raven • Smoke • Stone

Coat Options **Metallics** ☉☉ Antique Brass • Bronzed • Champagne • Cognac • Gold • Gunmetal • Pewter • Platinum

Anodics ☉ Glimmer • Glow • Midnight • Night Sky • Sky • Storm • Sunrise • Sunset • Twilight

Brights ☉ Can be specified at twice the cost of the standard finish | Polished Nickel

Matte ☉
Satin ☉
Gloss ☉

30mm (1³/₁₆"

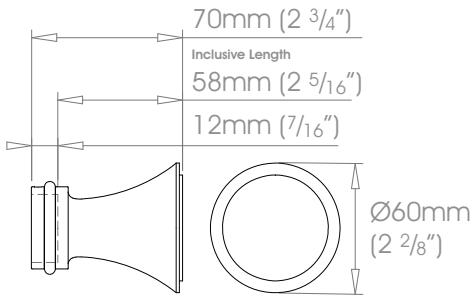

38mm (1¹/₂"

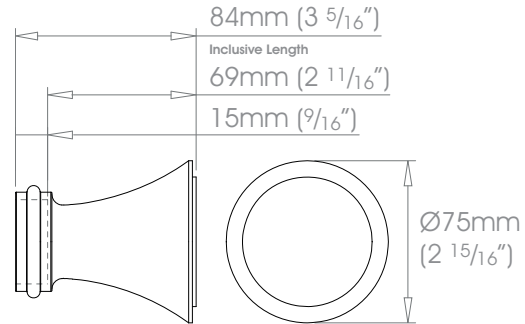

50mm (2"

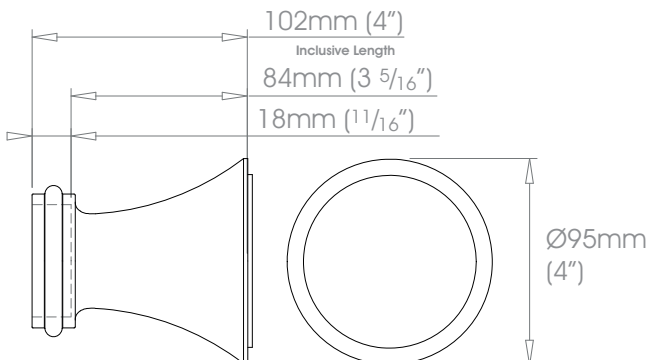



FINISHES Shades @@@ Alabaster • Barley • Bone • Burnt Ash • Charcoal • Clay • Cloud • Cocoa • Cream • Dove • Dusk • Earth • Flint • Frame Grey • Grey Moss
 Lead • Millstone • Mineral • Moss • Oatmeal • Parchment • Raven • Smoke • Stone
 Coat Options **Metallics** @@ Antique Brass • Bronzed • Champagne • Cognac • Gold • Gunmetal • Pewter • Platinum
Anodics Glimmer • Glow • Midnight • Night Sky • Sky • Storm • Sunrise • Sunset • Twilight
Brights Can be specified at twice the cost of the standard finish | Polished Nickel
 Matte @
 Satin @
 Gloss @

30mm (1³/₁₆"

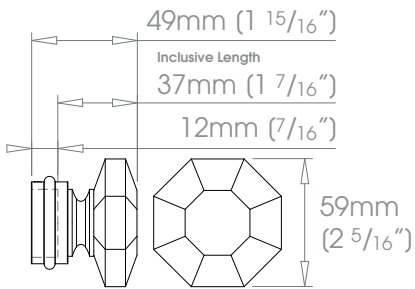

38mm (1¹/₂"

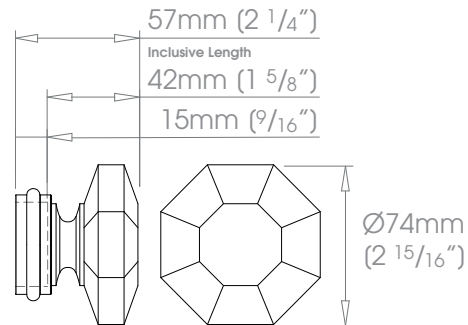

50mm (2")

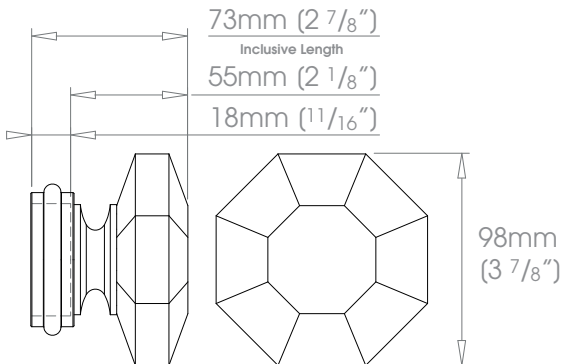



FINISHES Shades ☉☉☉ Alabaster • Barley • Bone • Burnt Ash • Charcoal • Clay • Cloud • Cocoa • Cream • Dove • Dusk • Earth • Flint • Frame Grey • Grey Moss
 Lead • Millstone • Mineral • Moss • Oatmeal • Parchment • Raven • Smoke • Stone
 Coat Options **Metallics** ☉☉ Antique Brass • Bronzed • Champagne • Cognac • Gold • Gunmetal • Pewter • Platinum
Anodics Glimmer • Glow • Midnight • Night Sky • Sky • Storm • Sunrise • Sunset • Twilight
Brights Can be specified at twice the cost of the standard finish | Polished Nickel
 Matte ☉
 Satin ☉
 Gloss ☉

30mm (1³/₁₆"

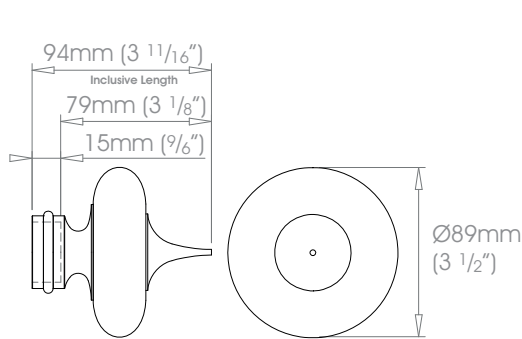

38mm (1¹/₂"

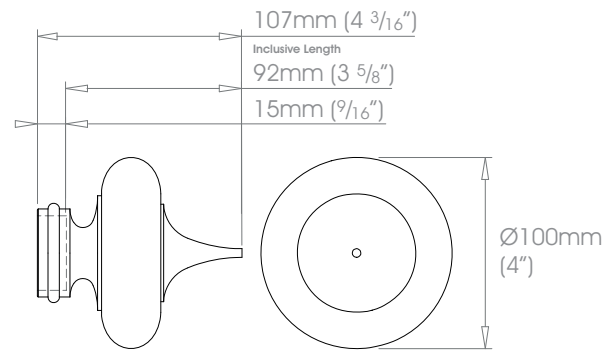

50mm (2")

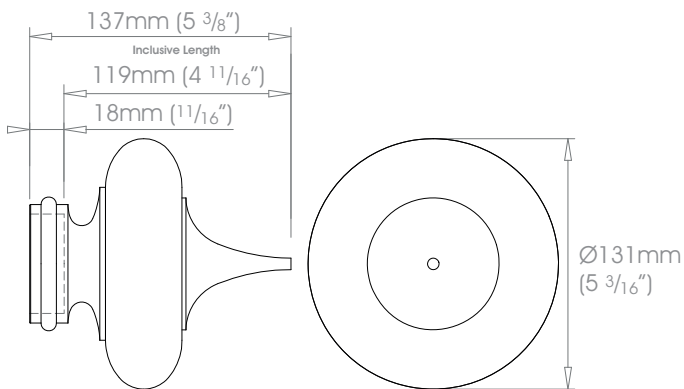



Crystal finials should not be positioned in direct sunlight and are not suitable for conservatories

FINISHES Shades ☉☉☉ Alabaster • Barley • Bone • Burnt Ash • Charcoal • Clay • Cloud • Cocoa • Cream • Dove • Dusk • Earth • Flint • Frame Grey • Grey Moss
 Lead • Millstone • Mineral • Moss • Oatmeal • Parchment • Raven • Smoke • Stone
 Coat Options **Metallics** ☉☉ Antique Brass • Bronzed • Champagne • Cognac • Gold • Gunmetal • Pewter • Platinum
Anodics ☉ Glimmer • Glow • Midnight • Night Sky • Sky • Storm • Sunrise • Sunset • Twilight
Brights ☉ Can be specified at twice the cost of the standard finish | Polished Nickel
 Matte ☉
 Satin ☉
 Gloss ☉

30mm (1 3/16")

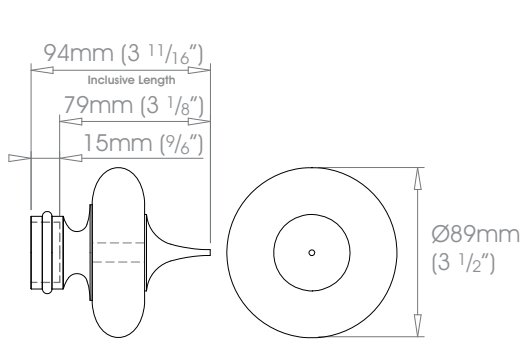

38mm (1 1/2")

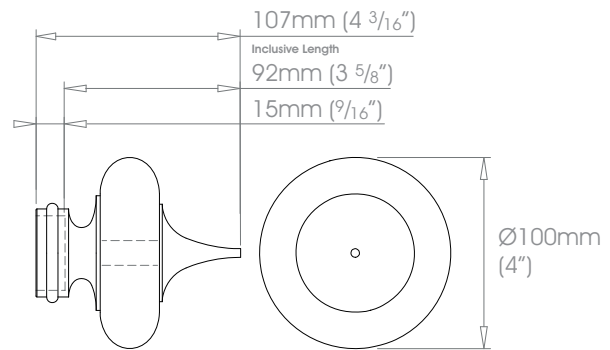

50mm (2")

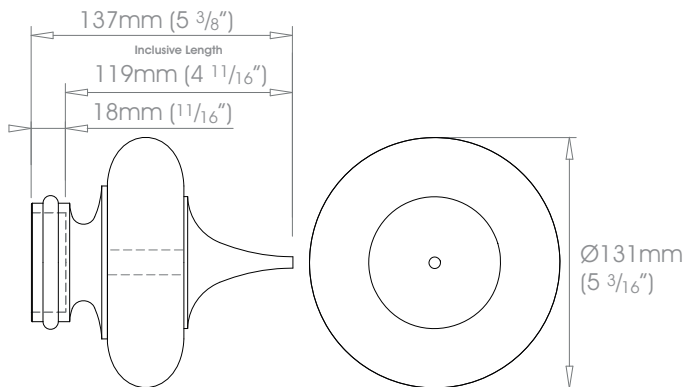



FINISHES **Shades** ☉☉☉ Alabaster • Barley • Bone • Burnt Ash • Charcoal • Clay • Cloud • Cocoa • Cream • Dove • Dusk • Earth • Flint • Frame Grey • Grey Moss • Lead • Millstone • Mineral • Moss • Oatmeal • Parchment • Raven • Smoke • Stone

Coat Options **Metallics** ☉☉ Antique Brass • Bronzed • Champagne • Cognac • Gold • Gunmetal • Pewter • Platinum

Anodics ☉ Glimmer • Glow • Midnight • Night Sky • Sky • Storm • Sunrise • Sunset • Twilight

Brights ☉ Can be specified at twice the cost of the standard finish | Polished Nickel

Matte ☉
Satin ☉
Gloss ☉

30mm (1 3/16")

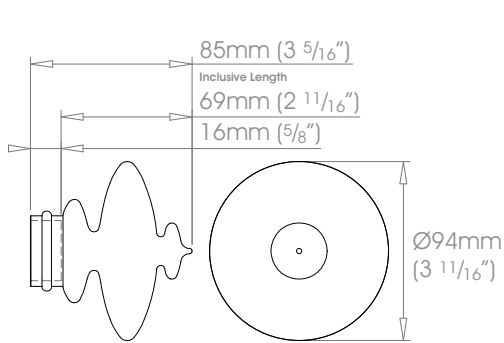

38mm (1 1/2")

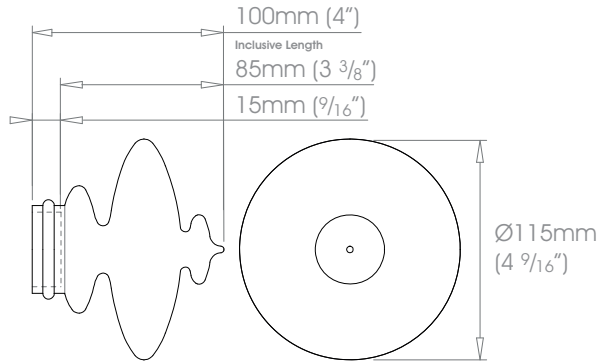

50mm (2")

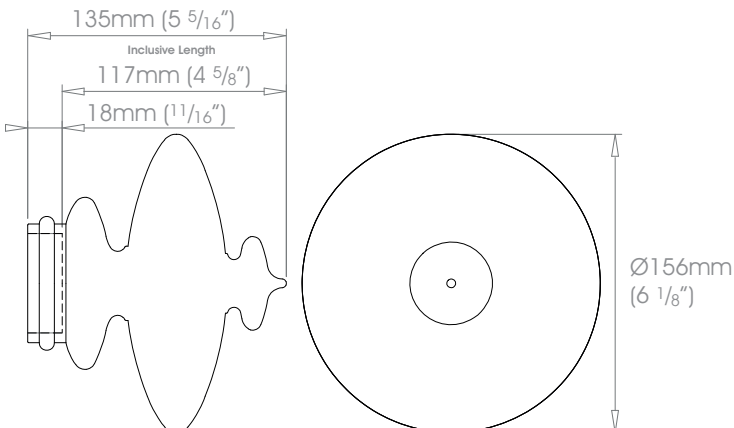



FINISHES Shades @@@ Alabaster • Barley • Bone • Burnt Ash • Charcoal • Clay • Cloud • Cocoa • Cream • Dove • Dusk • Earth • Flint • Frame Grey • Grey Moss
 Lead • Millstone • Mineral • Moss • Oatmeal • Parchment • Raven • Smoke • Stone
 Coat Options **Metallics** @@ Antique Brass • Bronzed • Champagne • Cognac • Gold • Gunmetal • Pewter • Platinum
Anodics @ Glimmer • Glow • Midnight • Night Sky • Sky • Storm • Sunrise • Sunset • Twilight
 Matte @ **Brights** @ Polished Nickel
 Satin @
 Gloss @
Can be specified at twice the cost of the standard finish

30mm (1 3/16")

38mm (1 1/2")

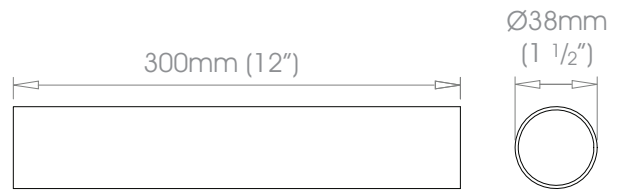
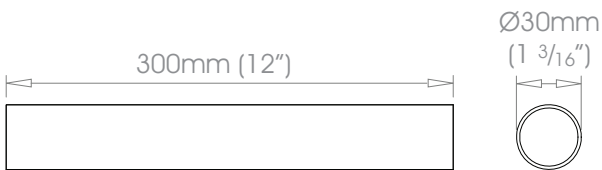

50mm (2")

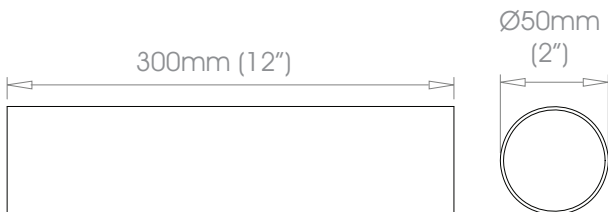



FINISHES Shades @@@ Alabaster • Barley • Bone • Burnt Ash • Charcoal • Clay • Cloud • Cocoa • Cream • Dove • Dusk • Earth • Flint • Frame Grey • Grey Moss
 Lead • Millstone • Mineral • Moss • Oatmeal • Parchment • Raven • Smoke • Stone
 Coat Options **Metallics** @@ Antique Brass • Bronzed • Champagne • Cognac • Gold • Gunmetal • Pewter • Platinum
Anodics Glimmer • Glow • Midnight • Night Sky • Sky • Storm • Sunrise • Sunset • Twilight
Brights Can be specified at twice the cost of the standard finish | Polished Nickel
 Matte @
 Satin @
 Gloss @

30mm (1³/₁₆"

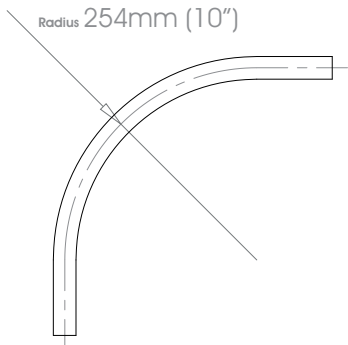

38mm (1¹/₂"

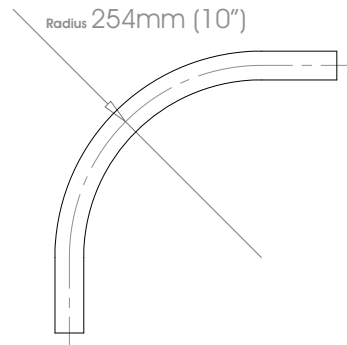

50mm (2"

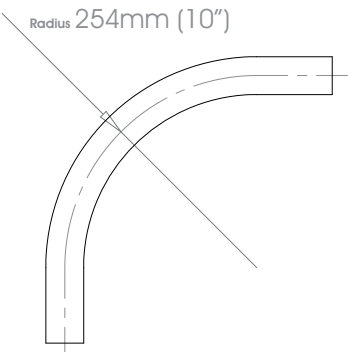



30mm (1 3/16") - NOT AVAILABLE

38mm (1 1/2")

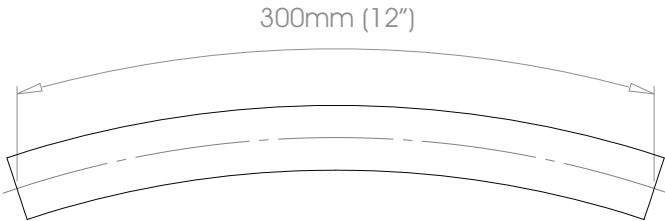

50mm (2")

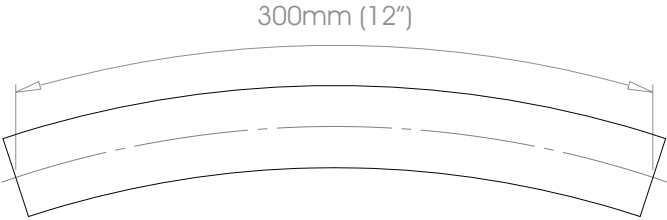

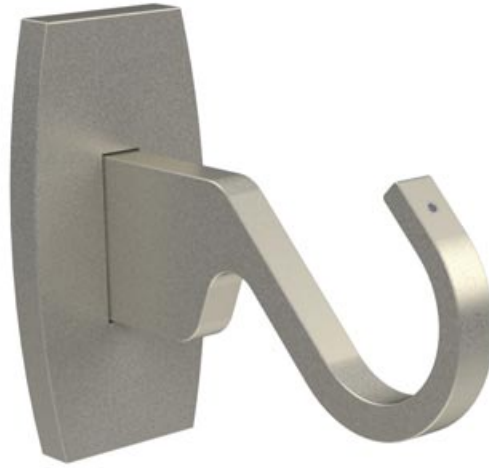

 For custom brackets see page 9

FINISHES **Shades** @@@ Alabaster • Barley • Bone • Burnt Ash • Charcoal • Clay • Cloud • Cocoa • Cream • Dove • Dusk • Earth • Flint • Frame Grey • Grey Moss • Lead • Millstone • Mineral • Moss • Oatmeal • Parchment • Raven • Smoke • Stone

Coat Options **Metallics** @@ Antique Brass • Bronzed • Champagne • Cognac • Gold • Gunmetal • Pewter • Platinum

Matte @ **Anodics** @ Glimmer • Glow • Midnight • Night Sky • Sky • Storm • Sunrise • Sunset • Twilight

Satin @ **Brights** @ Can be specified at twice the cost of the standard finish | Polished Nickel

Gloss @

30mm (1 3/16")

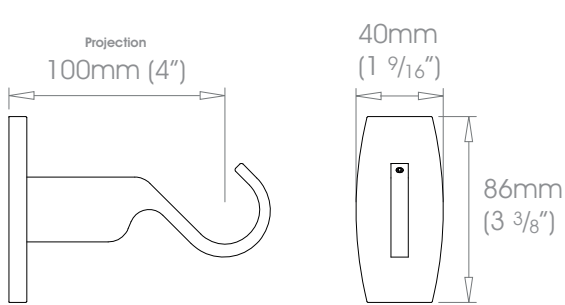

38mm (1 1/2")

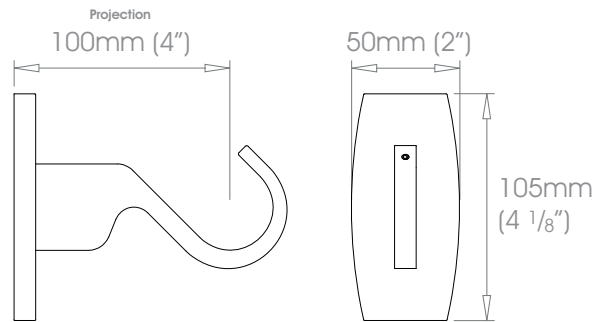

50mm (2")

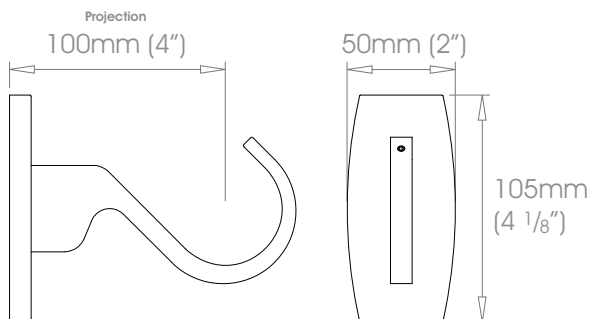



For custom brackets see page 9

FINISHES Shades @@@ Alabaster • Barley • Bone • Burnt Ash • Charcoal • Clay • Cloud • Cocoa • Cream • Dove • Dusk • Earth • Flint • Frame Grey • Grey Moss
 Lead • Millstone • Mineral • Moss • Oatmeal • Parchment • Raven • Smoke • Stone
 Coat Options **Metallics** @@ Antique Brass • Bronzed • Champagne • Cognac • Gold • Gunmetal • Pewter • Platinum
Anodics Glimmer • Glow • Midnight • Night Sky • Sky • Storm • Sunrise • Sunset • Twilight
Brights Can be specified at twice the cost of the standard finish | Polished Nickel
 Matte @
 Satin @
 Gloss @

30mm (1 3/16")

38mm (1 1/2")

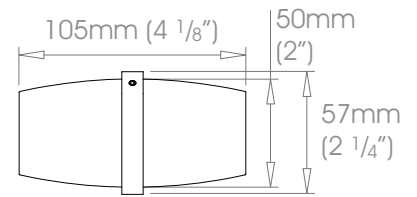
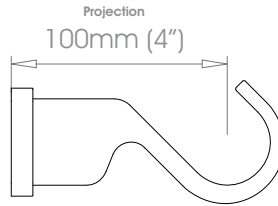
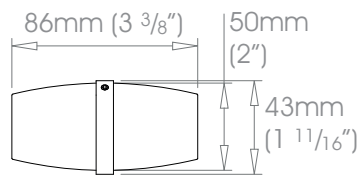
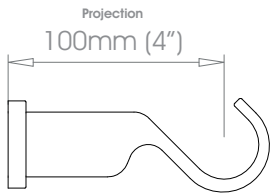

50mm (2")

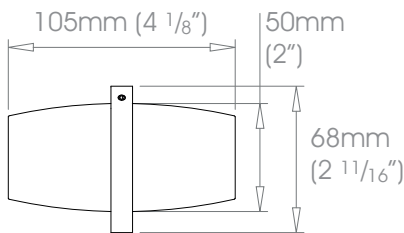
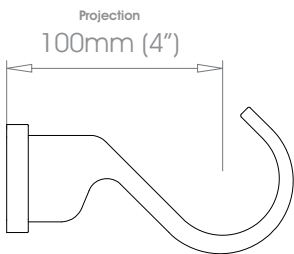



For custom brackets see page 9

FINISHES Shades @@@ Alabaster • Barley • Bone • Burnt Ash • Charcoal • Clay • Cloud • Cocoa • Cream • Dove • Dusk • Earth • Flint • Frame Grey • Grey Moss
 Lead • Millstone • Mineral • Moss • Oatmeal • Parchment • Raven • Smoke • Stone
 Coat Options **Metallics** @@ Antique Brass • Bronzed • Champagne • Cognac • Gold • Gunmetal • Pewter • Platinum
Anodics Glimmer • Glow • Midnight • Night Sky • Sky • Storm • Sunrise • Sunset • Twilight
Brights Can be specified at twice the cost of the standard finish | Polished Nickel
 Matte @
 Satin @
 Gloss @

30mm (1 3/16")

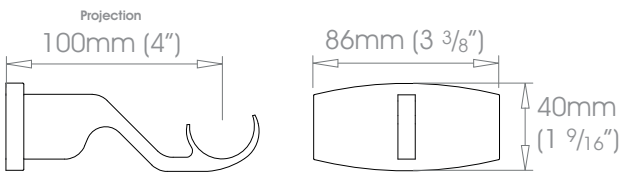

38mm (1 1/2")

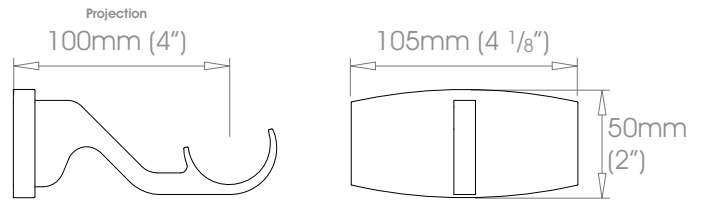

50mm (2")

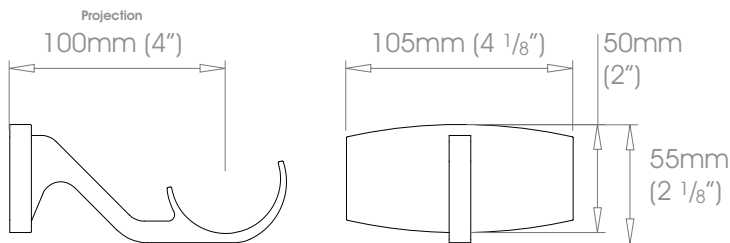



 For custom brackets see page 9

FINISHES Shades  Alabaster • Barley • Bone • Burnt Ash • Charcoal • Clay • Cloud • Cocoa • Cream • Dove • Dusk • Earth • Flint • Frame Grey • Grey Moss • Lead • Millstone • Mineral • Moss • Oatmeal • Parchment • Raven • Smoke • Stone

Coat Options **Metallics**  Antique Brass • Bronzed • Champagne • Cognac • Gold • Gunmetal • Pewter • Platinum

Anodics Glimmer • Glow • Midnight • Night Sky • Sky • Storm • Sunrise • Sunset • Twilight

Brights *Can be specified at twice the cost of the standard finish* | Polished Nickel

Matte 
 Satin 
 Gloss 

30mm (1 3/16")

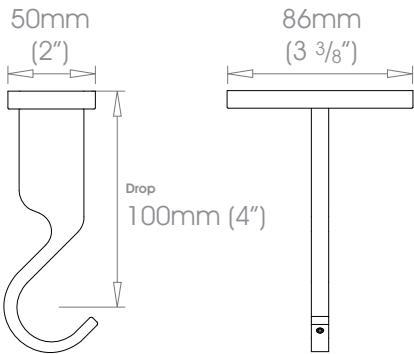

38mm (1 1/2")

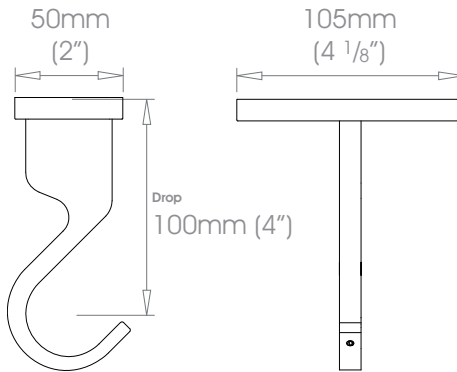

50mm (2")

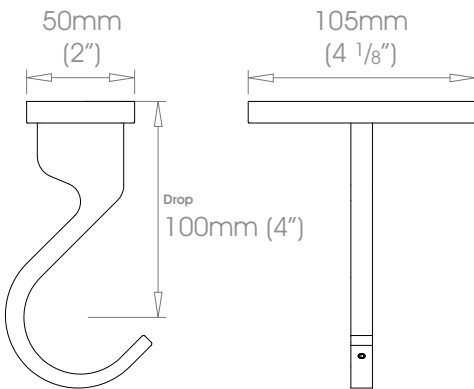



For custom brackets see page 9

FINISHES Shades ●●● Alabaster • Barley • Bone • Burnt Ash • Charcoal • Clay • Cloud • Cocoa • Cream • Dove • Dusk • Earth • Flint • Frame Grey • Grey Moss • Lead • Millstone • Mineral • Moss • Oatmeal • Parchment • Raven • Smoke • Stone
 Coat Options **Metallics** ●● Antique Brass • Bronzed • Champagne • Cognac • Gold • Gunmetal • Pewter • Platinum
Anodics ● Glimmer • Glow • Midnight • Night Sky • Sky • Storm • Sunrise • Sunset • Twilight
Brights ● Can be specified at twice the cost of the standard finish | Polished Nickel
 Matte ●
 Satin ●
 Gloss ●

30mm (1 3/16")

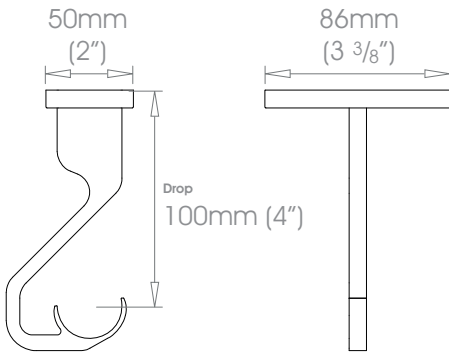

38mm (1 1/2")

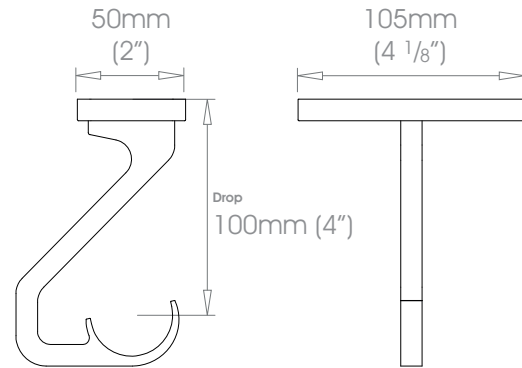

50mm (2")

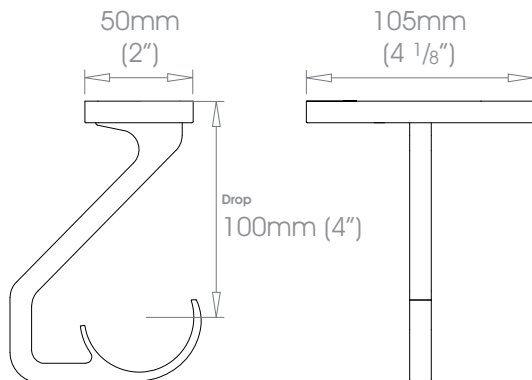



FINISHES Shades ☉☉☉ Alabaster • Barley • Bone • Burnt Ash • Charcoal • Clay • Cloud • Cocoa • Cream • Dove • Dusk • Earth • Flint • Frame Grey • Grey Moss
 Lead • Millstone • Mineral • Moss • Oatmeal • Parchment • Raven • Smoke • Stone
 Coat Options **Metallics** ☉☉☉ Antique Brass • Bronzed • Champagne • Cognac • Gold • Gunmetal • Pewter • Platinum
Anodics Glimmer • Glow • Midnight • Night Sky • Sky • Storm • Sunrise • Sunset • Twilight
Brights Can be specified at twice the cost of the standard finish | Polished Nickel
 Matte ☉
 Satin ☉
 Gloss ☉

30mm (1³/₁₆"

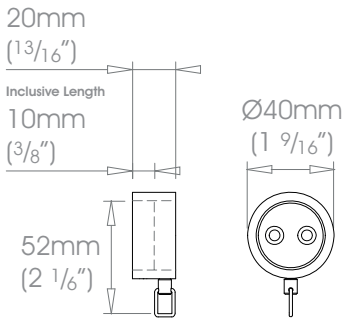

38mm (1¹/₂"

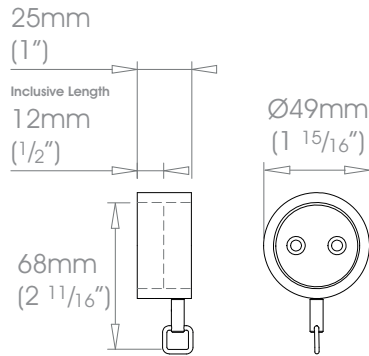

50mm (2"

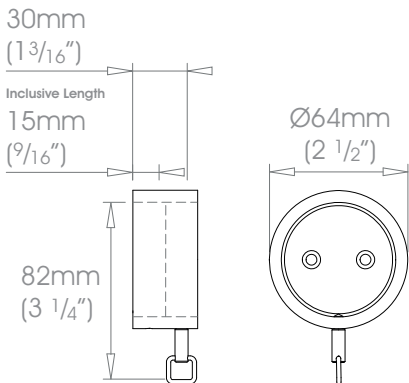

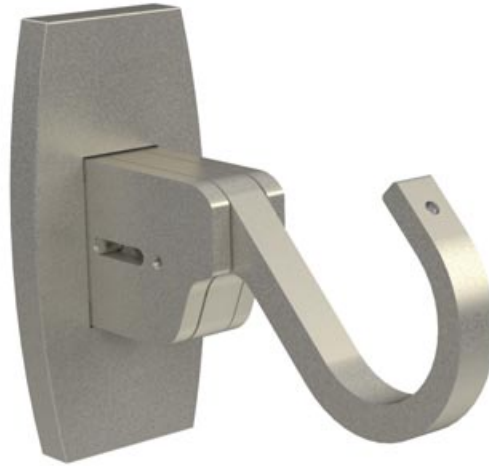

FINISHES **Shades** ◎◎◎ Alabaster • Barley • Bone • Burnt Ash • Charcoal • Clay • Cloud • Cocoa • Cream • Dove • Dusk • Earth • Flint • Frame Grey • Grey Moss
 Lead • Millstone • Mineral • Moss • Oatmeal • Parchment • Raven • Smoke • Stone
Coat Options **Metallics** ◎◎ Antique Brass • Bronzed • Champagne • Cognac • Gold • Gunmetal • Pewter • Platinum
Anodics ◎ Glimmer • Glow • Midnight • Night Sky • Sky • Storm • Sunrise • Sunset • Twilight
Brights ◎ Can be specified at twice the cost of the standard finish | Polished Nickel
 Matte ◎
 Satin ◎
 Gloss ◎

30mm (1 3/16")

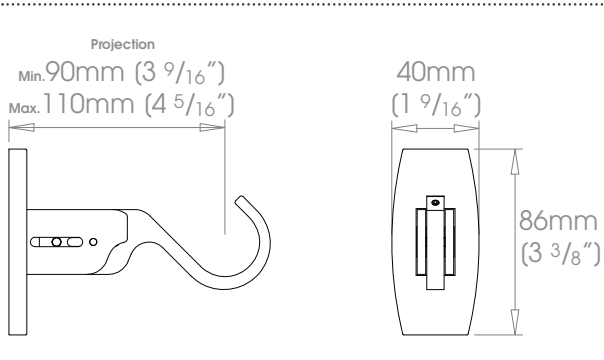

38mm (1 1/2")

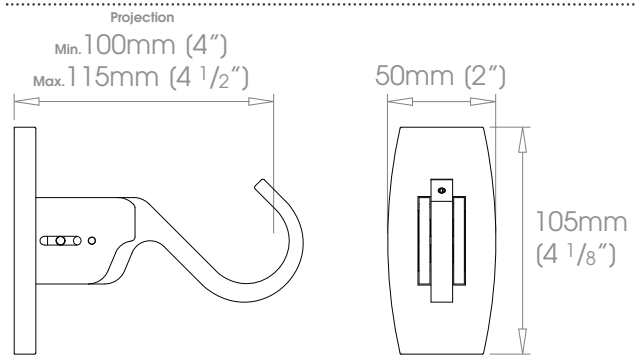



FINISHES **Shades** ☉☉☉ Alabaster • Barley • Bone • Burnt Ash • Charcoal • Clay • Cloud • Cocoa • Cream • Dove • Dusk • Earth • Flint • Frame Grey • Grey Moss
 Lead • Millstone • Mineral • Moss • Oatmeal • Parchment • Raven • Smoke • Stone
Coat Options **Metallics** ☉☉ Antique Brass • Bronzed • Champagne • Cognac • Gold • Gunmetal • Pewter • Platinum
Anodics Glimmer • Glow • Midnight • Night Sky • Sky • Storm • Sunrise • Sunset • Twilight
Brights Can be specified at twice the cost of the standard finish | Polished Nickel
 Matte ☉
 Satin ☉
 Gloss ☉

30mm (1³/₁₆"

38mm (1¹/₂"

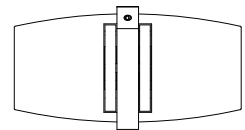
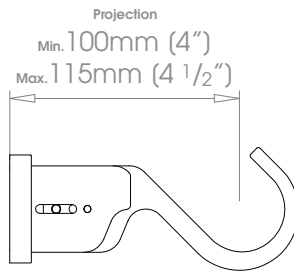
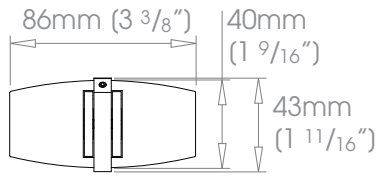
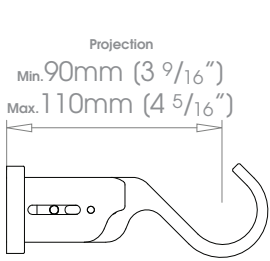



FINISHES **Shades** ☉☉☉ Alabaster • Barley • Bone • Burnt Ash • Charcoal • Clay • Cloud • Cocoa • Cream • Dove • Dusk • Earth • Flint • Frame Grey • Grey Moss
 Lead • Millstone • Mineral • Moss • Oatmeal • Parchment • Raven • Smoke • Stone
Coat Options **Metallics** ☉☉ Antique Brass • Bronzed • Champagne • Cognac • Gold • Gunmetal • Pewter • Platinum
Anodics Glimmer • Glow • Midnight • Night Sky • Sky • Storm • Sunrise • Sunset • Twilight
Brights Can be specified at twice the cost of the standard finish | Polished Nickel
Matte ☉
Satin ☉
Gloss ☉

30mm (1³/₁₆"

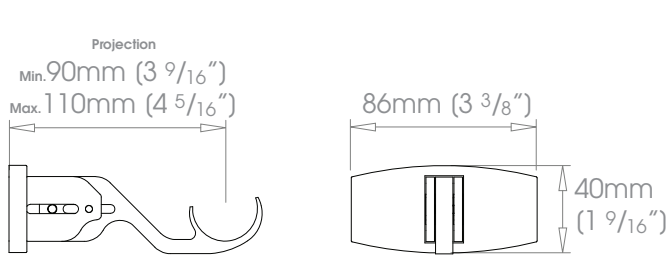

38mm (1¹/₂"

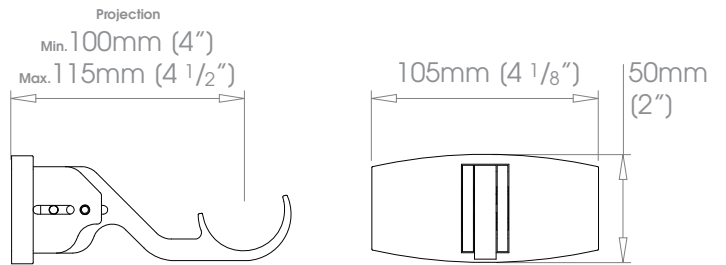

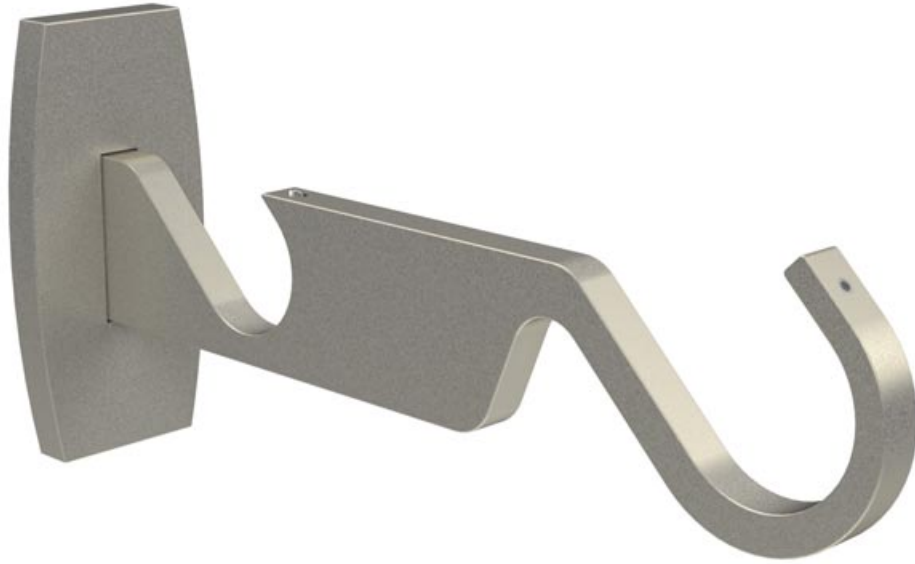

FINISHES Shades ☉☉☉ Alabaster • Barley • Bone • Burnt Ash • Charcoal • Clay • Cloud • Cocoa • Cream • Dove • Dusk • Earth • Flint • Frame Grey • Grey Moss
 Lead • Millstone • Mineral • Moss • Oatmeal • Parchment • Raven • Smoke • Stone
 Coat Options **Metallics** ☉☉ Antique Brass • Bronzed • Champagne • Cognac • Gold • Gunmetal • Pewter • Platinum
Anodics Glimmer • Glow • Midnight • Night Sky • Sky • Storm • Sunrise • Sunset • Twilight
Brights Can be specified at twice the cost of the standard finish | Polished Nickel
 Matte ☉
 Satin ☉
 Gloss ☉

ƒ38mm (1 1/2") ƒ30mm (1 3/16")

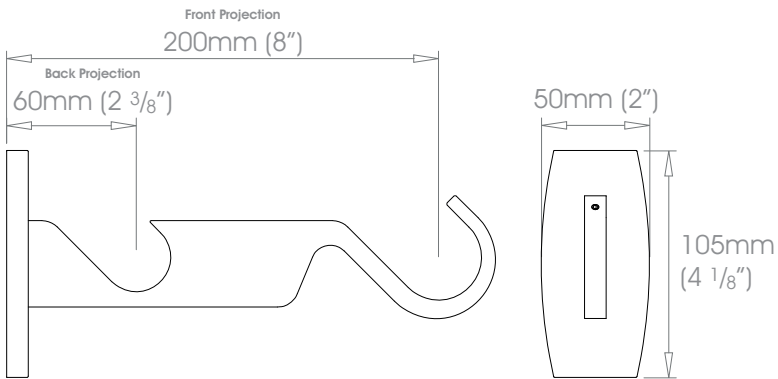

ƒ50mm (2") ƒ30mm (1 3/16")

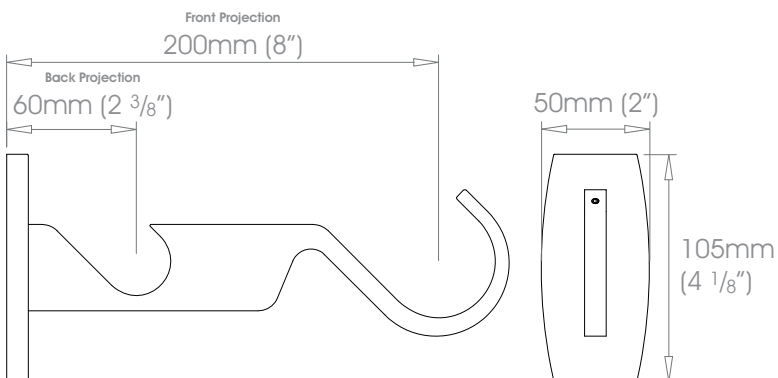

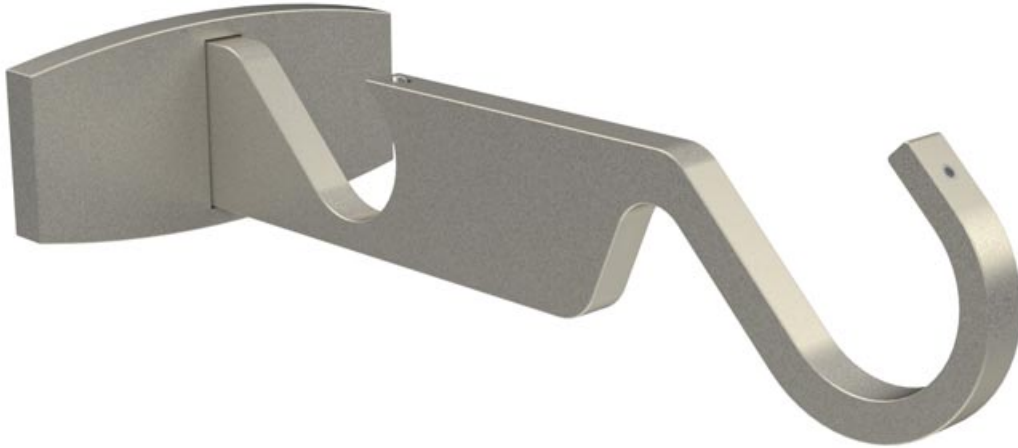

FINISHES Shades ☉☉☉ Alabaster • Barley • Bone • Burnt Ash • Charcoal • Clay • Cloud • Cocoa • Cream • Dove • Dusk • Earth • Flint • Frame Grey • Grey Moss
 Lead • Millstone • Mineral • Moss • Oatmeal • Parchment • Raven • Smoke • Stone
 Coat Options **Metallics** ☉☉ Antique Brass • Bronzed • Champagne • Cognac • Gold • Gunmetal • Pewter • Platinum
Anodics ☉ Glimmer • Glow • Midnight • Night Sky • Sky • Storm • Sunrise • Sunset • Twilight
Brights ☉ Can be specified at twice the cost of the standard finish | Polished Nickel
 Matte ☉
 Satin ☉
 Gloss ☉

F38mm (1 1/2") B30mm (1 3/16")

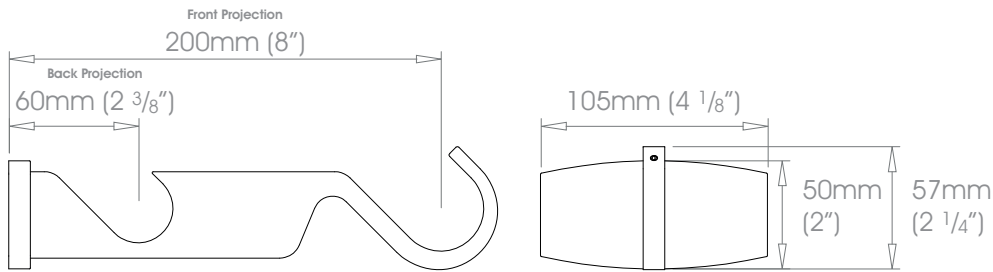

F50mm (2") B30mm (1 3/16")

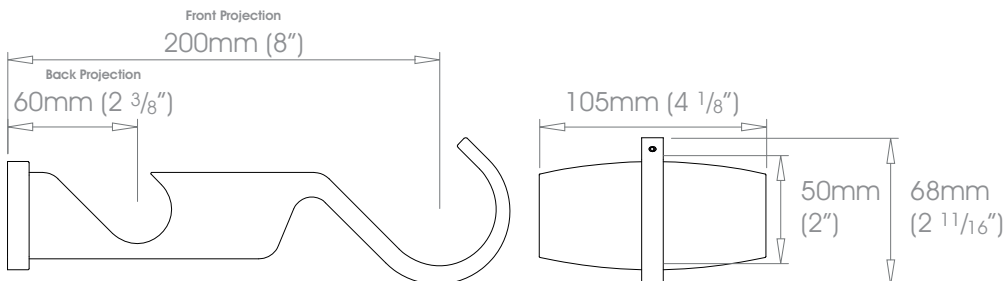

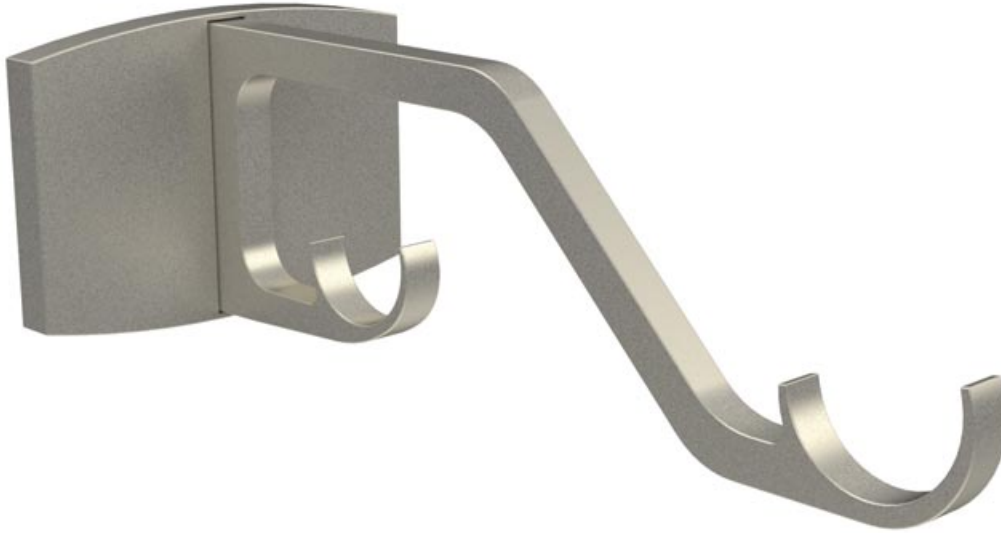

FINISHES **Shades** ☉☉☉ Alabaster • Barley • Bone • Burnt Ash • Charcoal • Clay • Cloud • Cocoa • Cream • Dove • Dusk • Earth • Flint • Frame Grey • Grey Moss
 Lead • Millstone • Mineral • Moss • Oatmeal • Parchment • Raven • Smoke • Stone
Coat Options **Metallics** ☉☉ Antique Brass • Bronzed • Champagne • Cognac • Gold • Gunmetal • Pewter • Platinum
Anodics ☉ Glimmer • Glow • Midnight • Night Sky • Sky • Storm • Sunrise • Sunset • Twilight
Brights ☉ Can be specified at twice the cost of the standard finish | Polished Nickel
 Matte ☉
 Satin ☉
 Gloss ☉

F38mm (1 1/2") B30mm (1 3/16")

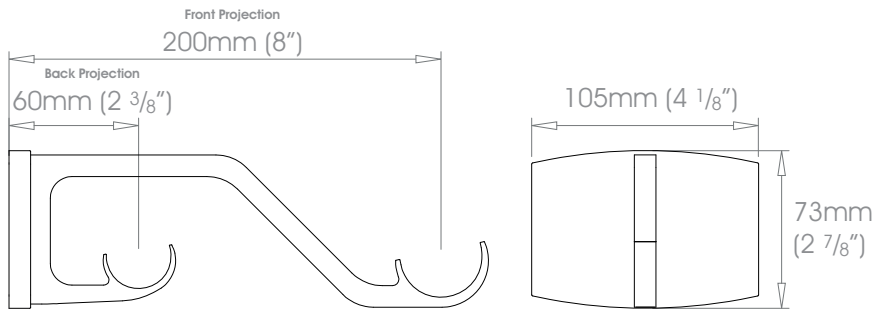

F50mm (2") B30mm (1 3/16")

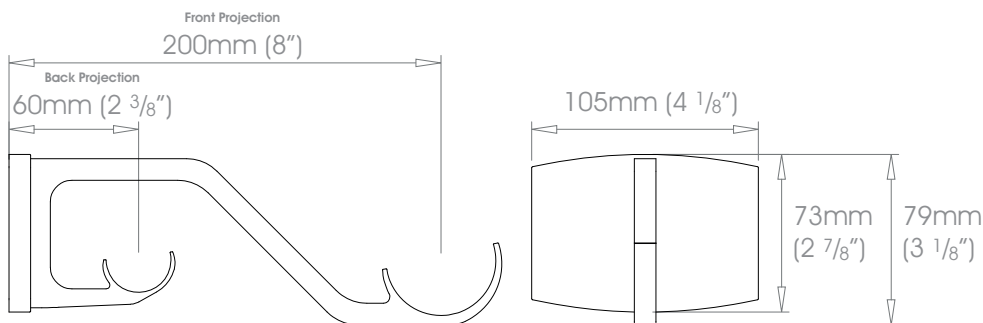

ELYSIAN

RINGS



FINISHES Shades ◎◎◎ Alabaster • Barley • Bone • Burnt Ash • Charcoal • Clay • Cloud • Cocoa • Cream • Dove • Dusk • Earth • Flint • Frame Grey • Grey Moss
 Lead • Millstone • Mineral • Moss • Oatmeal • Parchment • Raven • Smoke • Stone
 Coat Options **Metallics** ◎◎ Antique Brass • Bronzed • Champagne • Cognac • Gold • Gunmetal • Pewter • Platinum
Anodics Glimmer • Glow • Midnight • Night Sky • Sky • Storm • Sunrise • Sunset • Twilight
Brights Can be specified at twice the cost of the standard finish | Polished Nickel
 Matte ◎
 Satin ◎
 Gloss ◎

30mm (1 3/16")

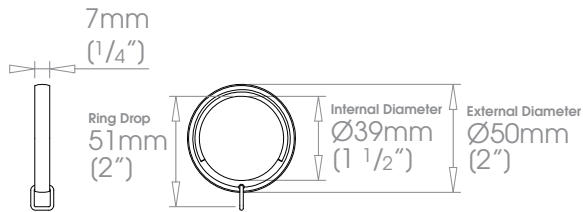

38mm (1 1/2")

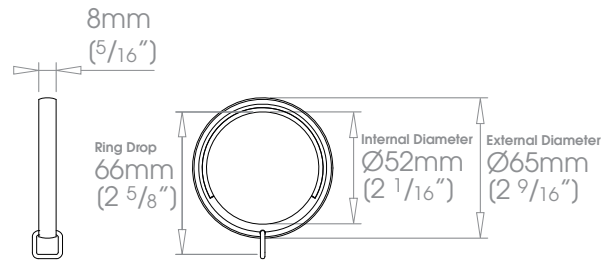

50mm (2")

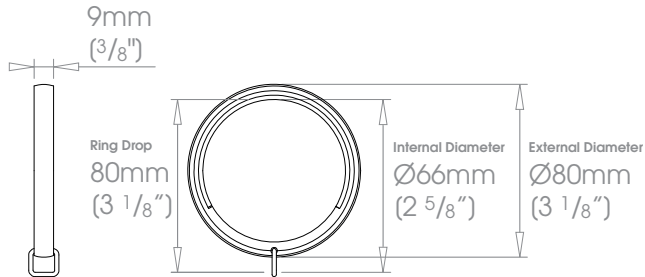



FINISHES **Shades** ☉☉☉ Alabaster • Barley • Bone • Burnt Ash • Charcoal • Clay • Cloud • Cocoa • Cream • Dove • Dusk • Earth • Flint • Frame Grey • Grey Moss
 Lead • Millstone • Mineral • Moss • Oatmeal • Parchment • Raven • Smoke • Stone
Coat Options **Metallics** ☉☉ Antique Brass • Bronzed • Champagne • Cognac • Gold • Gunmetal • Pewter • Platinum
Anodics Glimmer • Glow • Midnight • Night Sky • Sky • Storm • Sunrise • Sunset • Twilight
Brights Can be specified at twice the cost of the standard finish | Polished Nickel
 Matte ☉
 Satin ☉
 Gloss ☉

30mm (1 3/16")

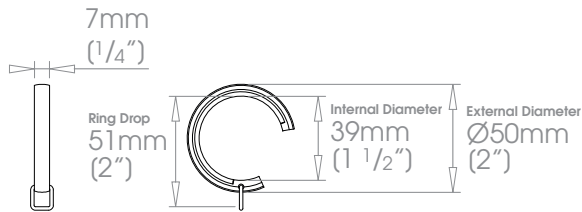

38mm (1 1/2")

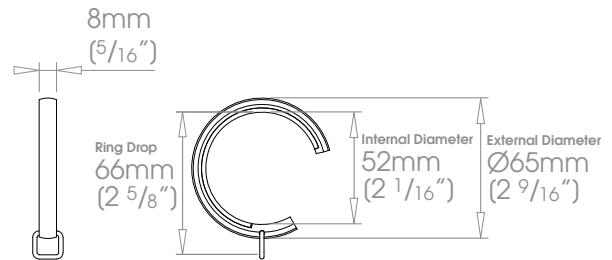

50mm (2")

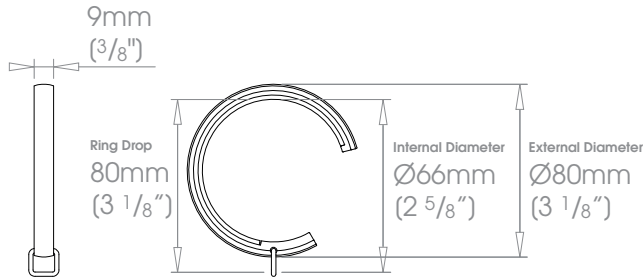



FINISHES **Shades** @@@ Alabaster • Barley • Bone • Burnt Ash • Charcoal • Clay • Cloud • Cocoa • Cream • Dove • Dusk • Earth • Flint • Frame Grey • Grey Moss
 Lead • Millstone • Mineral • Moss • Oatmeal • Parchment • Raven • Smoke • Stone
Coat Options **Metallics** @@ Antique Brass • Bronzed • Champagne • Cognac • Gold • Gunmetal • Pewter • Platinum
Anodics @ Glimmer • Glow • Midnight • Night Sky • Sky • Storm • Sunrise • Sunset • Twilight
Brights @ Can be specified at twice the cost of the standard finish | Polished Nickel
Matte @
Satin @
Gloss @

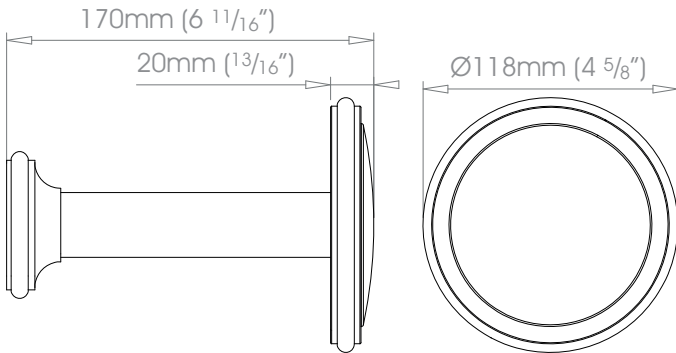



FINISHES **Shades** @@@ Alabaster • Barley • Bone • Burnt Ash • Charcoal • Clay • Cloud • Cocoa • Cream • Dove • Dusk • Earth • Flint • Frame Grey • Grey Moss
 Lead • Millstone • Mineral • Moss • Oatmeal • Parchment • Raven • Smoke • Stone
Coat Options **Metallics** @@ Antique Brass • Bronzed • Champagne • Cognac • Gold • Gunmetal • Pewter • Platinum
Anodics @ Glimmer • Glow • Midnight • Night Sky • Sky • Storm • Sunrise • Sunset • Twilight
Brights @ Can be specified at twice the cost of the standard finish | Polished Nickel
 Matte @
 Satin @
 Gloss @

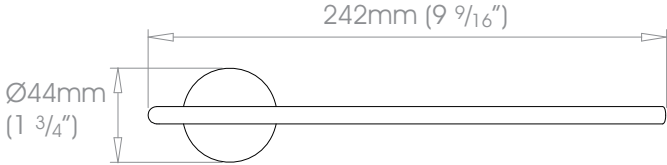
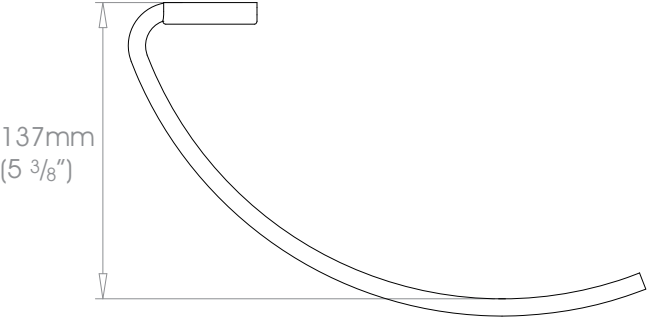



FINISHES Shades @@@ Alabaster • Barley • Bone • Burnt Ash • Charcoal • Clay • Cloud • Cocoa • Cream • Dove • Dusk • Earth • Flint • Frame Grey • Grey Moss
 Lead • Millstone • Mineral • Moss • Oatmeal • Parchment • Raven • Smoke • Stone
 Coat Options **Metallics** @@ Antique Brass • Bronzed • Champagne • Cognac • Gold • Gunmetal • Pewter • Platinum
Anodics Glimmer • Glow • Midnight • Night Sky • Sky • Storm • Sunrise • Sunset • Twilight
Brights Can be specified at twice the cost of the standard finish | Polished Nickel
 Matte @
 Satin @
 Gloss @

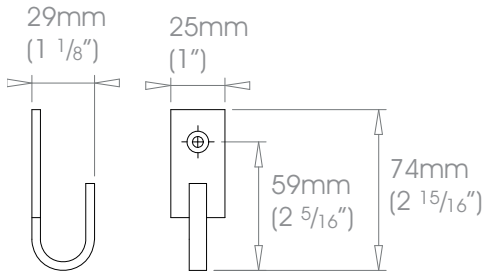

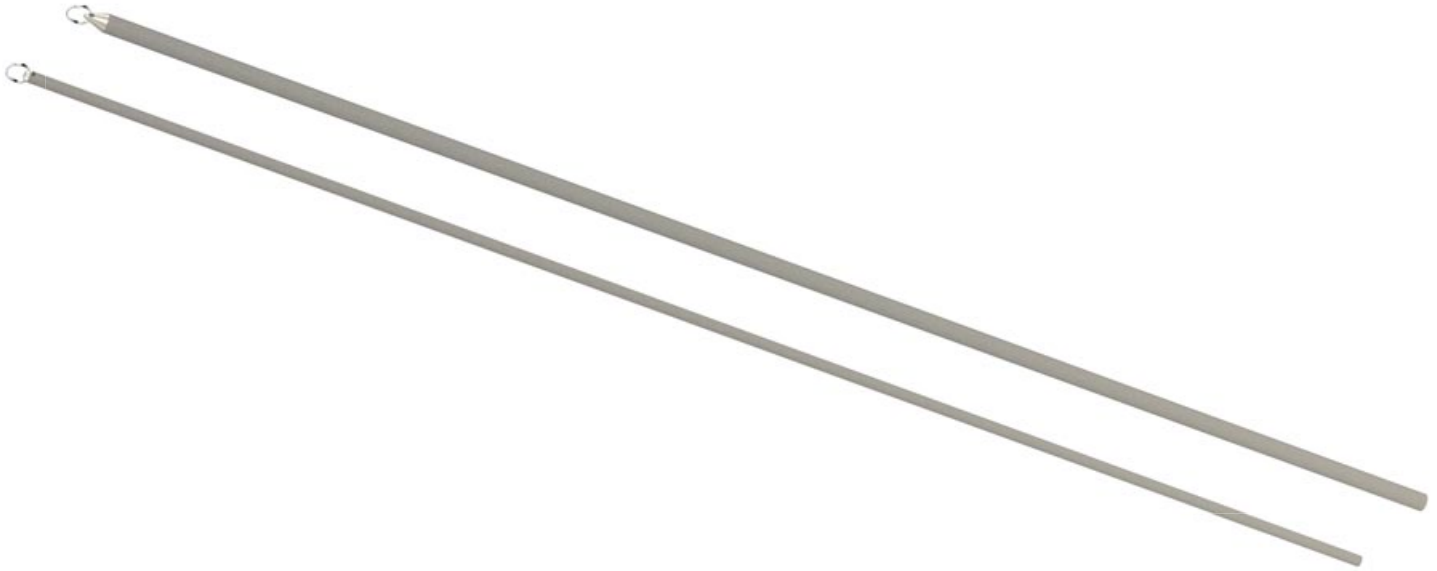

! Draw rods are not recommended for use with passing rings

- FINISHES**
- Shades** ☉☉☉ Alabaster • Barley • Bone • Burnt Ash • Charcoal • Clay • Cloud • Cocoa • Cream • Dove • Dusk • Earth • Flint • Frame Grey • Grey Moss • Lead • Millstone • Mineral • Moss • Oatmeal • Parchment • Raven • Smoke • Stone
- Coat Options**
- Matte** ☉
- Satin** ☉
- Gloss** ☉
- Metallics** ☉☉
- Anodics**
- Brights** Polished Nickel
- Can be specified at twice the cost of the standard finish*

Fine

Standard

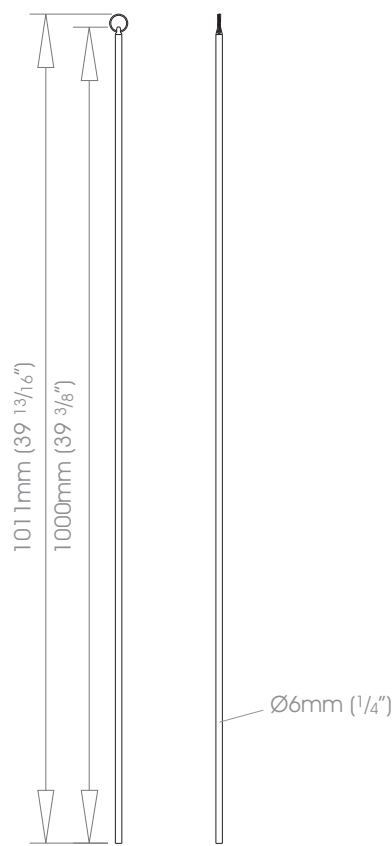

CONTACT

www.bradleycollection.com



UK & REST OF THE WORLD

☎ +44 (0)1449 722 724

✉ info@bradleycollection.com

USA & CANADA

☎ +1 (310) 815 8255

✉ info.us@bradleycollection.com

LONDON SHOWROOM

☎ +44 (0)207 871 7793

✉ showroom@studiotwochelsea.com

THE BRADLEY COLLECTION



Industry Partner

Supporting the interior design profession

CEDIA
MEMBER

Specialised fixings for mounting brackets will be required in certain situations and are not provided as standard. Steel items are not recommended for damp conditions such as shower rooms. Crystal finials should not be positioned in direct sunlight, and are not suitable for use in conservatories.

The Bradley Collection reserves the right to modify design and materials without prior notice as part of a process of continual product improvement. Due to printing limitations, colours in this brochure may not be accurate.

Products are protected by Design Rights, under provisions of Copyright, Designs & Patents Act 1988. Bradley® and The Bradley Collection® are registered Community trademarks of The Bradley Collection Ltd. in Europe and registered trademarks of the Bradley Collection, Inc. in the USA. Gliderpole is a registered trademark of The Bradley Collection Ltd in the UK.

The Bradley Collection Ltd Lion Barn • Maitland Road • Needham Market • Suffolk • IP6 8NS • UK
The Bradley Collection Inc 10866 Washington Blvd #1275 • Culver City • CA 90232 • USA

Published: 1125 • Copyright © The Bradley Collection Ltd. 2025