

POWERED BY



**SilentGliss**

**THE BRADLEY  
COLLECTION**

TECHNICAL GUIDE

# ⚡ | SILENT GLISS 5600

## TECHNICAL GUIDE

This technical guide has been designed to be used alongside our ⚡ | Electric collections specification guides.

If you have any questions, please contact your local sales representative or The Bradley Collection directly.



Electrical installations must be carried out by qualified professionals, in accordance with the relevant wiring diagrams and local regulations.

**Track Configurations** Page 3-7

PROFILE Page 4

⚡ | ELECTRIC Page 5-6

HAND DRAWN Page 7

**Curtain Information** Page 8-14

**Motors** Page 15-19

**Controls** Page 20-24

**THE BRADLEY  
COLLECTION**



Systems are manufactured to suit individual requirements. When calculating the length of your system, remember to allow tolerance beyond the width of the frame for the curtains to draw back to the edge of the window.

Systems exceeding the recommended maximum distance between brackets, will be cut into equal parts unless otherwise specified. Joiners will be supplied. Joining brackets should be placed at every join.



Motor Type	Maximum system length	Maximum system length
	Single Stack ▶	Pair Stack ▶◀
Glider/Wave - Glider	2900mm (9'6")	6000mm (20')
Roller/Wave - Roller	25000mm (82)*	25000mm (82)*

\* Up to 12m (82') Touch & Go, manual override, auto programming mode

### HAND DRAWN

For windows or double treatments where motorisation is not required, hand drawn option are available.

### GLIDERS & ROLLERS

Systems ordered with Standard Gliders & Rollers will be supplied as shown below.

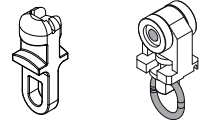

### SINGLE STACK ▶

---

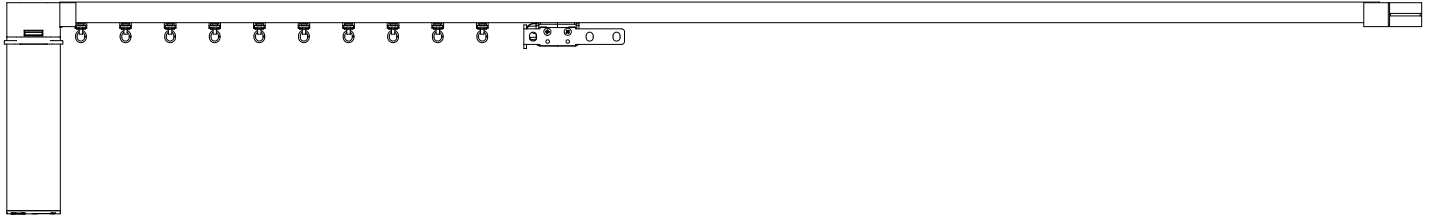

Supplied with 1x Overlap Arm. (SG 10820)

### PAIR STACK ▶◀

---

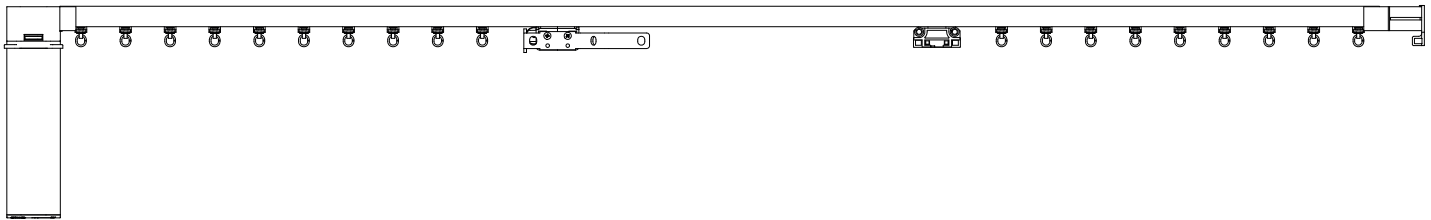

Supplied with 2x Overlap Arm (SG 10821). 1x Return Hook (SG 10836).



For Specification info on Overlap arms and Hook Points see page 13.

### WAVE® GLIDERS & ROLLERS

Systems ordered with Wave Gliders & Rollers will be supplied as shown below.

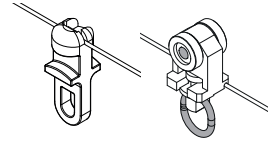

#### SINGLE STACK ▶

---



Supplied with 1x Wave Enhancement Arm (SG10845).

#### PAIR STACK ▶◀

---

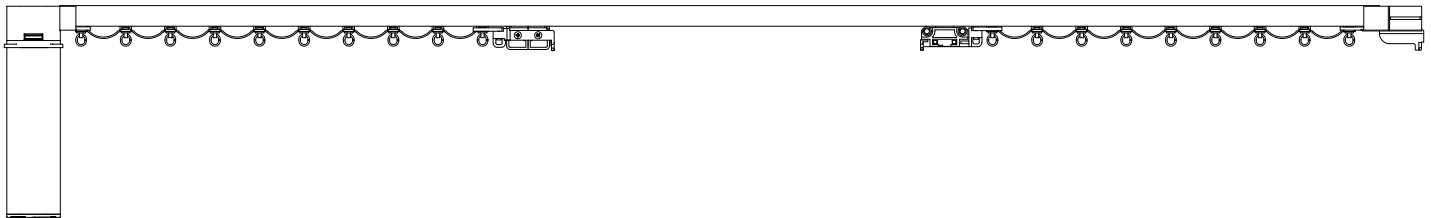

Supplied with 2x Wave Enhancement Arm. (SG10856 - SG10856 - SG10887)



For Specification info on Overlap arms and Hook Points see page 14.

### GLIDERS & ROLLERS

Systems ordered with Gliders & Rollers will be supplied as shown below.

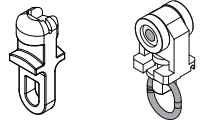

#### SINGLE STACK ▶

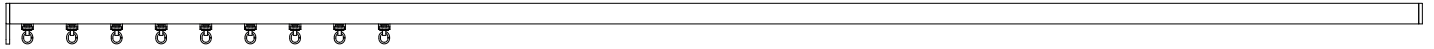

#### PAIR STACK ▶◀

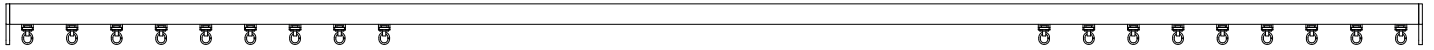

### WAVE® GLIDERS & ROLLERS

Systems ordered with Wave Gliders & Rollers will be supplied as per the diagrams below.

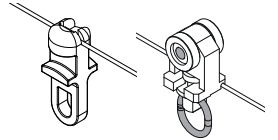

#### SINGLE STACK ▶

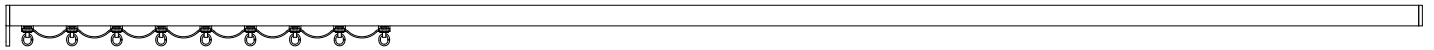

#### PAIR STACK ▶◀

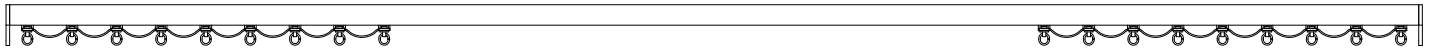

# ⚡ | SILENT GLISS 5600

CURTAIN INFORMATION

### STACKING OPTIONS

For electric systems, stacking configuration must be specified at the point of order, as it is set during assembly.

**Wave® curtains require stack type (single or pair) to be confirmed when ordering, as this determines the number of rollers supplied.**

#### SINGLE MOTOR - Single Stack ▶

On single stack systems the motor is always positioned on the stacking side. Allowing the motor to be hidden behind the curtain.



#### SINGLE MOTOR - Pair Stack ▶◀

Pair stack curtains can have the motor positioned at either end of the system. Curtains must be equal in length



### STACK SIZES

The stack area is the space where curtains gather when fully open. Positioning the stack over the wall, rather than the glazing, allows more natural light into the room during the day. As a guideline, allow approximately 30% of the track length for curtain stacking. Fuller curtain styles (e.g. pencil pleat) and lined or interlined fabrics will require additional space.

#### SINGLE STACK ▶



#### PAIR STACK ▶◀



### STANDARD HEADINGS

Standard rollers will be supplied every 100mm (4") unless otherwise specified.

Rollers can be loaded and removed from either end of the track after assembly by removal of the spring stop or return cover as shown.

**STANDARD**  
Fullness 1.5

**PINCH PLEAT**  
Fullness 2.0

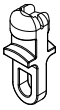
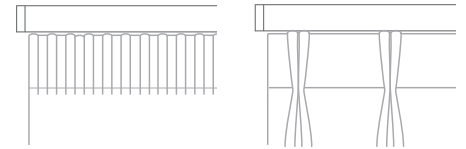

#### GLIDERS

Gliders are suitable for most installations. one glider is specified for every 100mm (4").



#### ROLLERS

Rollers are preferred for heavy drapery. One roller is specified for every 100mm (4").

### WAVE® HEADING

Wave® is a simple S folded heading system consisting of gliders spaced by a cord and a special pocketed header tape that is sewn onto a flat panel curtain. When assembled in the pole, the gliders/rollers on the cord are spaced at spacings shown below and this fixes the 'pitch' of the Wave. The flat panel curtain(s) are made in the conventional way with the pocketed Wave header tape sewn to the header. Hooks are fitted to header tape at a set spacing creating the Wave effect

#### WAVE®

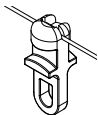
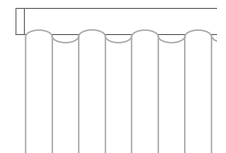

#### WAVE® GLIDERS

60mm (2 3/8") • 80mm (3 1/8") spacing between the Gliders

Roller-Cord Spacing	Curtain Hook Spacing	Approx. Curtain Fullness	Stack Depth <i>per 1M (39 1/8") of pole</i>	Min Bracket Projection
60mm (2 3/8")	120mm (4 3/4")	2.3	270mm (10 5/8")	100mm (4")
80mm (3 1/8")	160mm (6 5/16")	2.3	180mm (7 1/16")	100mm (4")

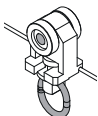

#### WAVE® ROLLERS

60mm (2 3/8") • 80mm (3 1/8") spacing between the Rollers.

Roller-Cord Spacing	Curtain Hook Spacing	Approx. Curtain Fullness	Stack Depth <i>per 1M (39 1/8") of pole</i>	Min Bracket Projection
60mm (2 3/8")	120mm (4 3/4")	2.3	270mm (10 5/8")	100mm (4")
80mm (3 1/8")	160mm (6 5/16")	2.3	180mm (7 1/16")	100mm (4")

### WAVE FABRIC SUITABILITY

There is no standard test that will indicate whether a fabric is suitable for Wave. However, experience suggests it is normally suitable for:

✓ Voiles • Lined cotton • Interlined Silk • Blackout lining

The soft curves of Wave do not lend themselves to:

✗ Stiff fabrics • Heavy embroidery • Irregular vertical stripes • Metallic threads

Different types of fabric have widely differing weights. The type of curtain heading used (see below) will determine the fullness of the fabric used: this can be anything from 1.5 x the width of the track to 3.0 x track width.

The chart below assumes 100% fullness (2.0 x width of the track) the weights are approximate values and can vary for many reasons. Always check the expected and final total curtain weight with the curtain maker. Based on 1200mm (48") fabric width

Curtain Type	Width↔/Drop↕	1m (3.5')	2m (7')	3m (10.5')	4m (14')	5m (16.5')	6m (20')
Print Cotton <i>(Light)</i>	1m (3.5')	0.8kg (1.8lb)	1.7kg (3.7lb)	2.5kg (5.5lb)	3.4kg (7.4lb)	4.2kg (9.2lb)	5.0kg (11.1lb)
	2m (7')	1.3kg (2.8lb)	2.5kg (5.5lb)	3.8kg (8.3lb)	5kg (11.1lb)	6.3kg (13.9lb)	7.6kg (16.6lb)
	3m (10')	1.7kg (3.7lb)	3.4kg (7.4lb)	5kg (11.1lb)	6.7kg (14.8lb)	8.4kg (18.5lb)	10kg (22lb)
Linen <i>(Medium)</i>	1m (3.5')	1.1kg (2.3lb)	2.1kg (4.6lb)	3.2kg (6.9lb)	4.2kg (9.2lb)	5.3kg (11.6lb)	6.3kg (13.9lb)
	2m (7')	1.6kg (3.5lb)	3.2kg (6.9lb)	4.7kg (10.4lb)	6.3kg (13.9lb)	7.9kg (17.3lb)	9.5kg (20.8lb)
	3m (10')	2.1kg (4.6lb)	4.2kg (9.2lb)	6.3kg (13.9lb)	8.4kg (18.5lb)	10.5kg (23.1lb)	12.6kg (27.7lb)
Velvet <i>(Heavy)</i>	1m (3.5')	1.5kg (3.2lb)	3.2kg (6.5lb)	4.4kg (9.7lb)	5.9kg (12.9lb)	7.4kg (16.2lb)	8.8kg (19.4lb)
	2m (7')	2.2kg (4.9lb)	4.4kg (9.7lb)	6.7kg (12.6lb)	8.8kg (19.4lb)	11kg (24.3lb)	13.2kg (22lb)
	3m (10')	2.9kg (6.5lb)	5.9kg (12.9lb)	8.8kg (19.4lb)	11.8kg (26lb)	14.7kg (32.2lb)	17.6kg (39lb)

Maximum weight recommendations for all standard curtain types using gliders & roller are defined to ensure safe and proper function of the electric system. These must be adhered to. See table below for details of all options.

**!** Bends will considerably reduce the load bearing capability of any system.

### GLIDERS

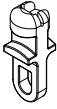

One glider is specified for every 100mm (4")

System Width <i>Single Stack ▶ / Pair Stack ▶◀</i>	Straight	1 Bend Bay	2 Bend Bay	4 Bend Bay	Curves
2m (6.5')	20kg (44lb)	20kg (44lb)	20kg (44lb)	4 BEND BAYS REQUIRE 2X 2 BEND BAY SYSTEMS	20kg
4m (13')	25kg (55lb)	20kg (44lb)	20kg (44lb)		20kg
6m (19.5')	25kg (55lb)	20kg (44lb)	20kg (44lb)		15kg (33lb)
8m (26')	25kg (55lb)	20kg (44lb)	15kg (33lb)		8kg (17.5lb)
10m (33')	20kg (44lb)	15kg (33lb)	10kg (22lb)		—

### ROLLERS

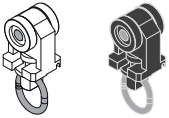

One roller is specified for every 100mm (4")

System Width <i>Single Stack ▶ / Pair Stack ▶◀</i>	Straight	1 Bend Bay	2 Bend Bay	4 Bend Bay	Curves
2m (6.5')	25kg (55lb)	25kg (55lb)	25kg (55lb)	4 BEND BAYS REQUIRE 2X 2 BEND BAY SYSTEMS	20kg (44lb)
4m (13')	45kg (99lb)	35kg (77lb)	30kg (66lb)		20kg (44lb)
6m (19.5')	45kg (99lb)	35kg (77lb)	30kg (66lb)		20kg (44lb)
8m (26')	50kg (110lb)	40kg (88lb)	30kg (66lb)		18kg (20lb)
10m (33')	65kg (143lb)	35kg (77lb)	25kg (55lb)		16kg (35lb)
12m (39.5')	45kg (99lb)	35kg (77lb)	25kg (55lb)		12kg (26lb)
15m (49')	45kg (99lb)	35kg (77lb)	22kg (48lb)		10kg (22lb)
18m (59')	45kg (99lb)	32kg (70lb)	19kg (42lb)		—
21m (69')	45kg (99lb)	29kg (64lb)	15kg (33lb)		—
25m (82')	40kg (88lb)	25kg (55lb)	—		—

### WAVE® GLIDERS

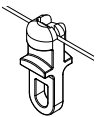

Glider spacing options  
60mm (2 3/8") • 80mm (3 1/8")

System Width <i>Single Stack ▶ / Pair Stack ▶◀</i>	Straight	1 Bend Bay	2 Bend Bay	4 Bend Bay	Curves
2m (6.5')	20kg (44lb)	20kg (44lb)	20kg (44lb)	4 BEND BAYS REQUIRE 2X 2 BEND BAY SYSTEMS	20kg
4m (13')	25kg (55lb)	20kg (44lb)	20kg (44lb)		20kg
6m (19.5')	25kg (55lb)	20kg (44lb)	20kg (44lb)		15kg (33lb)
8m (26')	25kg (55lb)	20kg (44lb)	15kg (33lb)		8kg (17.5lb)
10m (33')	20kg (44lb)	15kg (33lb)	10kg (22lb)		—

### WAVE® ROLLERS

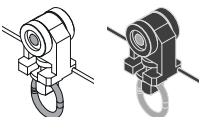

Roller spacing options  
60mm (2 3/8") • 80mm (3 1/8")

System Width <i>Single Stack ▶ / Pair Stack ▶◀</i>	Straight	1 Bend Bay	2 Bend Bay	4 Bend Bay	Curves
2m (6.5')	25kg (55lb)	25kg (55lb)	25kg (55lb)	4 BEND BAYS REQUIRE 2X 2 BEND BAY SYSTEMS	20kg (44lb)
4m (13')	45kg (99lb)	35kg (77lb)	30kg (66lb)		20kg (44lb)
6m (19.5')	45kg (99lb)	35kg (77lb)	30kg (66lb)		20kg (44lb)
8m (26')	50kg (110lb)	40kg (88lb)	30kg (66lb)		18kg (20lb)
10m (33')	65kg (143lb)	35kg (77lb)	25kg (55lb)		16kg (35lb)
12m (39.5')	45kg (99lb)	35kg (77lb)	25kg (55lb)		12kg (26lb)
15m (49')	45kg (99lb)	35kg (77lb)	22kg (48lb)		10kg (22lb)
18m (59')	45kg (99lb)	32kg (70lb)	19kg (42lb)		—
21m (69')	45kg (99lb)	29kg (64lb)	15kg (33lb)		—
25m (82')	40kg (88lb)	25kg (55lb)	—		—

### OVERLAP ARM - Single Stack ▶ (SG 10820)

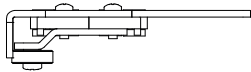
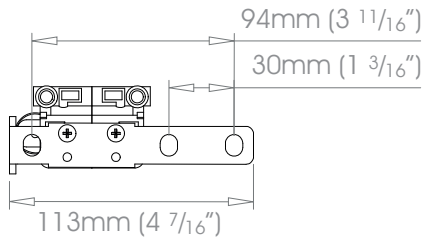

Supplied on single stack systems  
with Gliders or Rollers

### MOTOR SIDE OVERLAP ARM - Pair Stack ▶◀ (SG 10821)

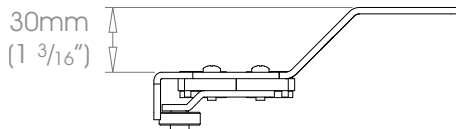
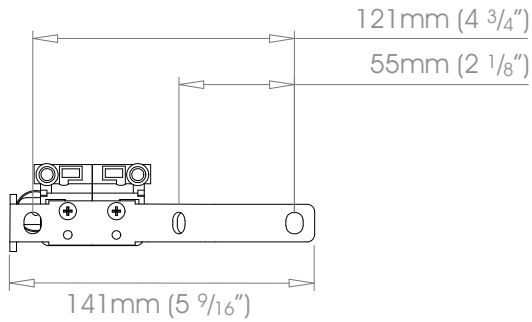

Supplied on pair stack systems  
with Gliders or Rollers

### RETURN SIDE OVERLAP ARM - Pair Stack ▶◀ (SG 10836)

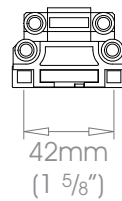

### WAVE CARRIER - Single Stack ▶ (SG 10845)

---

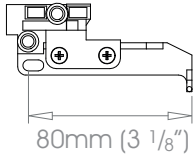

Supplied on single stack systems  
with Wave Gliders or Rollers

### MOTOR SIDE WAVE EXTENSION - Pair Stack ▶◀ (SG 10886)

---

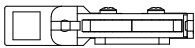
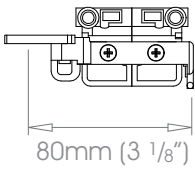

Supplied on pair stack systems  
with Wave Gliders or Rollers

### RETURN SIDE WAVE EXTENSION - Pair Stack ▶◀ (SG 10876)

---

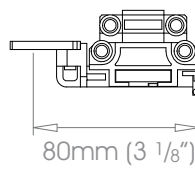

### RETURN END WAVE EXTENSION - Pair Stack ▶◀ (SG 10856)

---

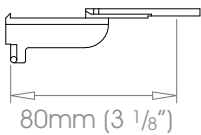

Supplied on pair stack systems  
with Wave Gliders or Rollers

# ⚡ | SILENT GLISS 5600

# ⚡ | SILENT GLISS 5600

## MOTOR POSITIONING

The mains-powered motor must be positioned on the same side of the window as the power supply.

Wiring diagrams are available upon request.

Motorised systems are unsuitable for use outdoors or in damp environments such as shower rooms and bathrooms.

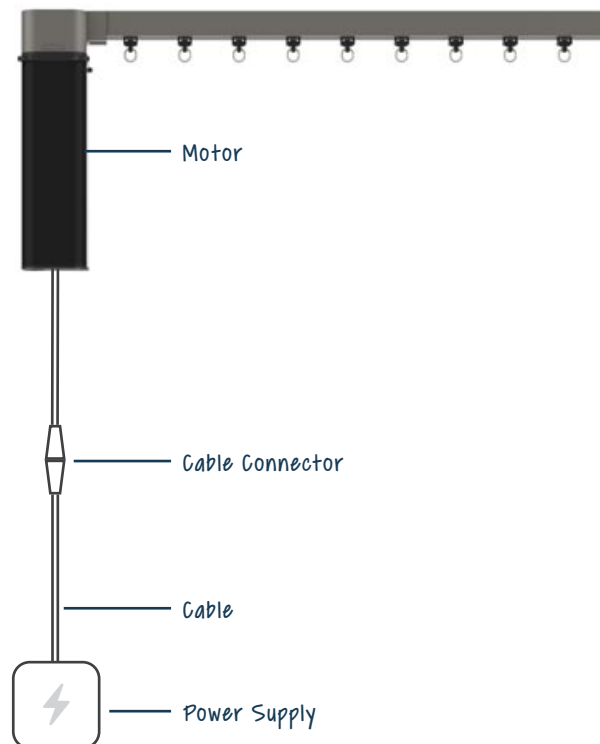

### LEFT HAND MOTOR



### RIGHT HAND MOTOR



The motor can be rotated, allowing you flexibility when installing and hanging your drapes

The motor is held in place by a clip in the motor block, this can be removed allowing the motor to easily be detached.

### **MOTOR IN-LINE**

This option allows the motor to run in-line with track



### **MOTOR PERPENDICULAR**

This option allows the motor to return to the wall.

This option should be used when using Wave heading as it allows the motor to sit in the waves of the curtains and not affect how your drapes hang.



# ⚡ SILENT GLISS 5600

9060 MOTOR

## ⚡ 9060 MOTOR

Size	ℓ206mm (8 <sup>1</sup> / <sub>8</sub> " ) x w93mm (3 <sup>3</sup> / <sub>4</sub> " ) x d60mm (2 <sup>3</sup> / <sub>8</sub> " )
Voltage	100-250v AC
Current	1.3 / 0.45 A
Noise	< 36 dBA
Speed	160 / 120 rpm
Max Length	15m (49')
Max Weight	65kg (143lb)
Control	Control N ( <i>Remotes &amp; App</i> ) • Smart • Low Voltage • Automation Systems
Additional Modules	11939 Control N Radio Module ( <i>Matter compatible</i> ) • 11270 Smart Module
Colour Options	Silver • White • Black

Matter Requires 11939 Module



MOTOR FEATURES	9060 Motor	9060 Motor + 11939 Radio Module	9060 Motor + 11270 Smart Module
Two motor speeds	✓	✓	✓
Internal transformer	✓	✓	✓
Quiet operation - noise level <36dBA 300mm (1')	✓	✓	✓
Overload protection	✓	✓	✓
Easy endstop setting (manual/automatic)	✓	✓	✓
Permanent positional sensor to keep end stops	✓	✓	✓
Power failure memory	✓	✓	✓
Manual operation during power failure	✓	✓	✓
Soft start / Soft stop	✓	✓	✓
Touch a go	✓	✓	✓

CONTROL FEATURES	9060 Motor	9060 Motor + 11939 Radio Module	9060 Motor + 11270 Smart Module
Mains Power Control	✓	✓	✓
Dry Contact Control	✓	✓	✓
Remote Control ( <i>Silent Gliss Control N</i> )	✗	✓	✗
App Control ( <i>Silent Gliss Move - Control N</i> )	✗	✓	✗
Smart by Silent Gliss	✗	✗	✓
Common home automation systems (With suitable interface)	✓	✓	✓
Matter Compatible	✗	✓	✗

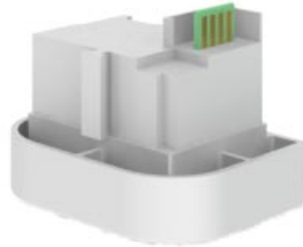

---

### SG 11939 Control N - Radio module

**Function** 1 channel

**Frequency** 433 MHz

**Features** Matter Compatible



---

### SG 11270 Smart module

Smart Module for SG 5600 system

Works exclusively with Smart Gateway components

**Features** Simple "plug in" module for SG 9060 motors  
Screw connector blocks

# ⚡ | SILENT GLISS 5600

CONTROLS

### REMOTE CONTROL

Single channel remote can control one motor or a group of motors at the same time.  
Multi channel remote can control multiple motors independently or grouped together.  
Remote control requires a 5600 motor fitted with the 11939 Radio module



---

### APP CONTROL

Motors can be controlled by Move by Silent Gliss

Operate your system from your smartphone, tablet, or desktop. Whether you are at home or on the road, this reliable and intuitive app allows you to program automatic opening and closing times. The system can also be set for automatic sunrise and sunset programming.

Move by Silent Gliss can be used independently or as a compliment to remote control options.

Move requires the Move Hub, and a 5600 motor fitted with the 11939 Radio module



---

### AUTOMATION SYSTEMS

The system can also be integrated with all major home control systems.

This will require additional components and the system being installed & commissioned by automation specialist's

Motors can also be integrated into the Silent Gliss Smart system allowing integrations with all major home automation systems.

Move requires the Smart gateway, and a 5600 motor fitted with the 11270 Smart module





Requires Silent Gliss 9060 motor and radio module SG 11939

### SG 11931 Single Channel Remote

---

**Function** 1 channel

**Frequency** 433 MHz

**Colour** White • Black

**Features** Operates single system or operates one group up to 5 systems  
Wall holder included

### SG 11932 Multi Channel Remote

---

**Function** 6 channel

**Frequency** 433 MHz

**Colour** White • Black

**Features** 6 channel: operates up to 6 single systems individually  
6 channel: operates up to 6 groups of up to 5 systems individually  
Several channels can be operated simultaneously  
Saves the selection of channels  
Wall holder in corresponding colour



Requires Silent Gliss 9060 motor and radio module SG 11939

## Move - Server

---

**Function** 6 channel

**Frequency** 433 MHz • 868 MHz

**Colour** Black

**Features** Operates up to 40 single systems individually  
App available for Android and IOS  
Various languages  
Programmable day and week, sunrise and sunset time  
Holiday mode  
Customised automation

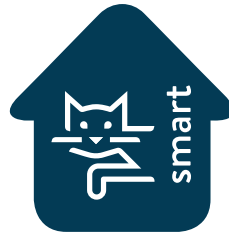

Requires Silent Gliss 9060 motor and Smart module SG 11270

Open designed two-way communication system which allows to flawlessly integrate products with most major home control systems

- 
- Full two way communication between motors and control system
  - Works in conjunction with specific third party control systems
  - Precise motor control
  - Wide range of Silent Gliss product types

# CONTACT

[www.bradleycollection.com](http://www.bradleycollection.com)



## UK & REST OF THE WORLD

☎ +44 (0)1449 722 724

✉ [info@bradleycollection.com](mailto:info@bradleycollection.com)

## USA & CANADA

☎ +1 (310) 815 8255

✉ [info.us@bradleycollection.com](mailto:info.us@bradleycollection.com)

---

## LONDON SHOWROOM

☎ +44 (0)207 871 7793

✉ [showroom@studiotwochelsea.com](mailto:showroom@studiotwochelsea.com)

## THE BRADLEY COLLECTION



CEDIA  
MEMBER

Specialised fixings for mounting brackets will be required in certain situations and are not provided as standard. Steel items are not recommended for damp conditions such as shower rooms. Crystal finials should not be positioned in direct sunlight, and are not suitable for use in conservatories.

The Bradley Collection reserves the right to modify design and materials without prior notice as part of a process of continual product improvement. Due to printing limitations, colours in this brochure may not be accurate.

Products are protected by Design Rights, under provisions of Copyright, Designs & Patents Act 1988. Bradley® and The Bradley Collection® are registered Community trademarks of The Bradley Collection Ltd. in Europe and registered trademarks of the Bradley Collection, Inc. in the USA. Gliderpole is a registered trademark of The Bradley Collection Ltd in the UK.

**The Bradley Collection Ltd** Lion Barn • Maitland Road • Needham Market • Suffolk • IP6 8NS • UK  
**The Bradley Collection Inc** 10866 Washington Blvd #1275 • Culver City • CA 90232 • USA

Published: 0426 • Copyright © The Bradley Collection Ltd. 2026