



LINEAR(2)

THE **BRADLEY**  
COLLECTION

SPECIFICATION GUIDE

## SPECIFICATION GUIDE

This specification guide was designed to outline the main considerations that need to be made when quoting or ordering a system.

Please use this alongside the Electric Technical Guides.

There is a guide for Silent Gliss • Somfy • Lutron system options which deal with specific details of those systems.

If any questions arise please call your local sales representative or contact The Bradley Collection directly.



**Electrical installations must be carried out by qualified professionals. In line with the relevant wiring diagrams and conform to local regulations.**

### System Information Page 3-30

**TRACKS** Page 4

**MOTOR OPTIONS** Page 5

**JOINTING SYSTEM** Page 6

**BAYS & MINIMUM WALL SIZES** Page 7

**BRACKET ALIGNMENT** Page 8

**CUSTOM BRACKETS** Page 9

**CURTAIN DROPS** Page 10

**SYSTEM CONFIGURATION** Page 11-15

**TRACK CONFIGURATION** Page 16-19

**CURTAIN STACKS** Page 20

**GLIDING OPTIONS & CURTAIN HEADINGS** Page 21-23

**CURTAIN WEIGHTS** Page 24

**MAXIMUM WEIGHTS** Page 25-26

**OVERLAP ARMS** Page 27-30

### Finishes Page 31-35

### Tracks Page 36-48

### Brackets Page 49-58



Tracks are cut, bent and curved to suit individual requirements. When calculating the length of your track, remember to allow a tolerance beyond the width of the frame for the curtains to stack back to the edge of the window.

Tracks exceeding the maximum length will be cut into equal parts unless otherwise specified. Joining system will be supplied. (See page 6) Brackets should be placed at every join.



Size	Maximum distance between brackets	Maximum length in one piece	Standard Bend radius
H27mm (1 <sup>1</sup> / <sub>8</sub> " ) W32mm (1 <sup>1</sup> / <sub>4</sub> " )	1000mm (39")	4000mm (157")Ⓞ	R275mm (10 <sup>13</sup> / <sub>16</sub> " )

Double Linear systems may be specified with a motor to front and rear. It is also possible to specify a motor to the main curtain and a manual track to the rear.

## PROVIDING TRACK LENGTHS

Track lengths can be specified in two ways.

**OPTION A** is our preferred method. This covers Track length only. **OPTION B** combines track and finial lengths.

**A - PREFERRED OPTION**

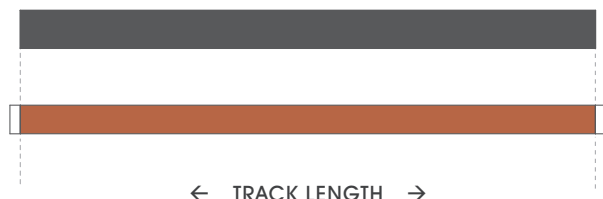

**B**

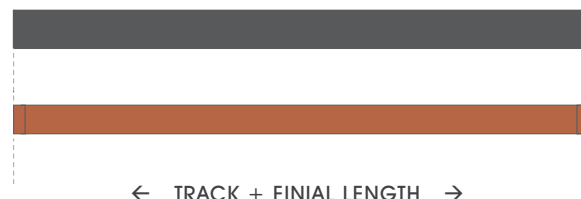

### SELECT TRACK TYPE & MOTOR

Specify your motor type from a choice from the leading brands. This provides power and control options ranging from standalone battery powered systems to fully integrated home automation solutions.



For double configurations a second MOTOR system can be specified. It is also possible to specify a motor to the main curtain and a manual track to the rear.

#### LUTRON



##### 1 MOTOR OPTIONS

- ⚡ D105
- ⚡ D145
- ⚡ D175

Radio dongle required for use to wireless control options

##### 2 CONTROL OPTIONS

###### Remote Control

Single hand held remote control option available.

###### App Control - RA2 Select

The system can be controlled with the Lutron app or through smart devices & Amazon Alexa.

###### Automation Systems

The system can also be integrated with all major home control systems.<sup>(A)</sup>

#### SOMFY

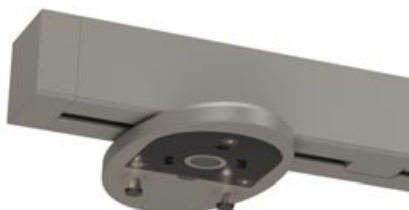

##### 1 MOTOR OPTIONS

- ⚡ Glydea Ultra 60e WT
- ⚡ Glydea Ultra 60e RTS
- ⚡ Glydea Ultra 60e ZIGBEE 3.0
- 🔋 Irismo 45 WF RTS
- ⚡ Movelite 35 WT
- ⚡ Movelite 35 RTS
- 🔋 Movelite 35 WF RTS<sup>(C)</sup>

RTS required for use to wireless control options

##### 2 CONTROL OPTIONS

###### Remote Control

Single channel & Multi-channel hand held remote control options available.

###### App Control - Tahoma

The system can be controlled with the Somfy Tahoma app or through smart devices & Amazon Alexa.

###### Automation Systems

The system can also be integrated with all major home control systems.<sup>(A)</sup>

#### SILENT GLISS



##### 1 MOTOR OPTIONS

- ⚡ 9060 Motor
- ⚡ 9060 Motor with radio module

Radio module required for use to wireless control options

##### 2 CONTROL OPTIONS

###### Remote Control

Single & Multi-channel hand held remote control options available.

###### App Control - Move

The system can be controlled with the Silent Gliss Move<sup>(M)</sup> app to allow control on smart devices.

###### Automation Systems

The system can also be integrated with all major home control systems, and via Silent Gliss Smart<sup>(S)</sup> system allowing two way integration with all major home control systems.<sup>(A)</sup>

Linear's jointing system ensures perfect alignment between track sections.

Joins must always be supported by a bracket.

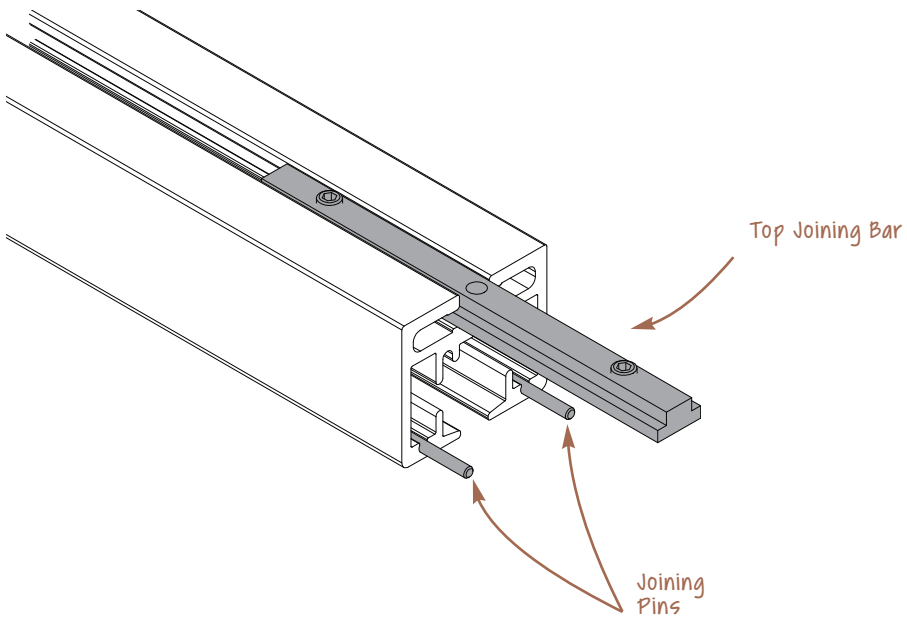

Bradley's bespoke service allows tracks to be specifically made for unique bay windows and complex long span installations. Tracks can be shaped to create a system that follows contours.

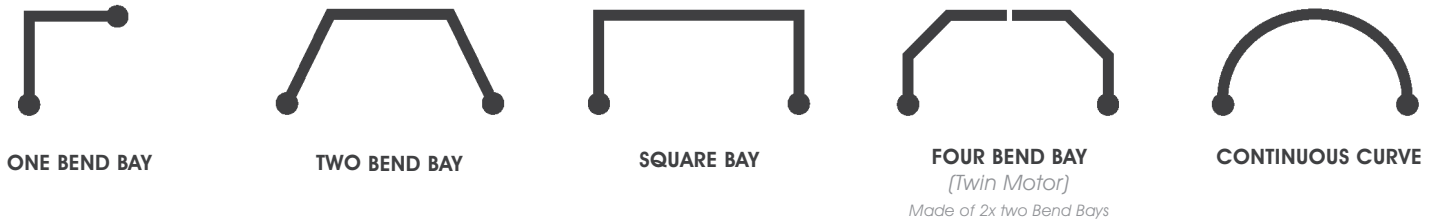

### MINIMUM WALL SIZES

The table below is a guide for the minimum wall size required.

The standard bend radius shown is the minimum radius achievable.

*Note: changes in angles and projections will alter the minimum wall sizes required*

#### 135° BEND ANGLES

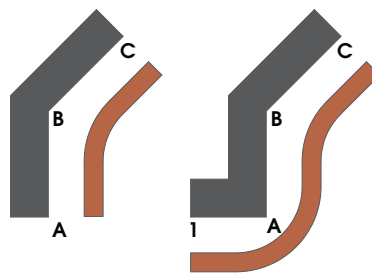

#### 90° BEND ANGLES

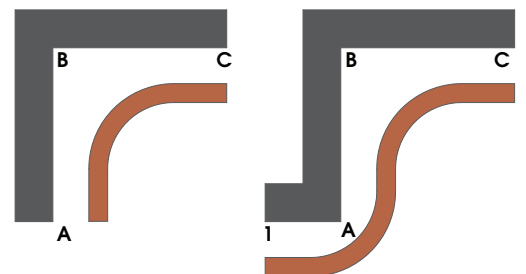

Size	Return 1-A	Wall A - B	Wall B - C	Angle at B	Standard Bend Radius	Projection
H27mm (1 <sup>1</sup> / <sub>16</sub> "	n/a	355mm (14")	330mm (13")	135°	275mm (10 <sup>13</sup> / <sub>16</sub> "	100mm (4")
H27mm (1 <sup>1</sup> / <sub>16</sub> "	256mm (10 <sup>1</sup> / <sub>16</sub> "	347mm (13 <sup>5</sup> / <sub>16</sub> "	387mm (15 <sup>1</sup> / <sub>4</sub> "	135°	275mm (10 <sup>13</sup> / <sub>16</sub> "	100mm (4")
H27mm (1 <sup>1</sup> / <sub>16</sub> "	n/a	575mm (22 <sup>5</sup> / <sub>8</sub> "	550mm (21 <sup>5</sup> / <sub>8</sub> "	90°	275mm (10 <sup>13</sup> / <sub>16</sub> "	100mm (4")
H27mm (1 <sup>1</sup> / <sub>16</sub> "	335mm (13 <sup>3</sup> / <sub>16</sub> "	685mm (26 <sup>15</sup> / <sub>16</sub> "	590mm (23 <sup>1</sup> / <sub>4</sub> "	90°	275mm (10 <sup>13</sup> / <sub>16</sub> "	140mm (5 <sup>1</sup> / <sub>2</sub> "

## BRADLEY BAY CHECKER +

Bay Checker + is part of our Digital Toolbox, allowing you to check your measurement for bays and curves whilst onsite, as well as storing straight window dimensions for your projects.

Unlimited measurements may be saved locally to your device or shared to your colleagues.

Available as a free download for iOS or Android.

For more information on Bay Checker + and latest enhancements to our Digital Toolbox visit

[www.bradleycollection.com/digital-toolbox/](http://www.bradleycollection.com/digital-toolbox/)

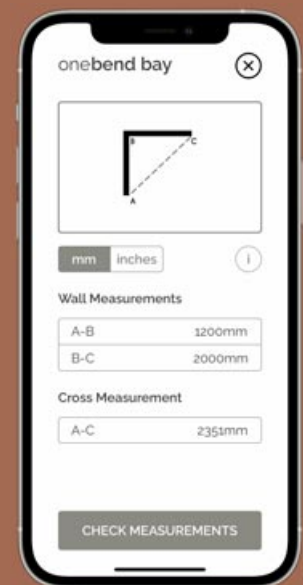

The information below shows the relationship between the bracket backplate. this will enable easy alignment during installation.

### SINGLE SYSTEM

Top of brackets

SIDE BRACKET

MID BRACKET

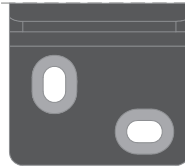
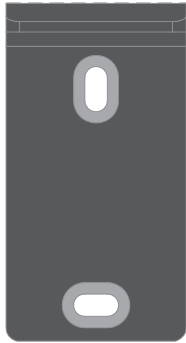

---

### DOUBLE SYSTEMS

Top of brackets

SIDE BRACKET

MID BRACKET

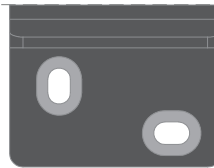

Linear can be customised to suit virtually any window. For simple projection changes between the minimums and maximums listed above, brackets are charged at double their standard cost. For all other customisations an additional up-charge and custom fee is applied per drawing.

### Custom Projection



*Specify the exact projection needed.*

### Custom Fixing Plate



*Relevant where space is restricted or weight is a concern.*

### Uplift



*Helps negotiate cornice & similar architectural features.*

### Ceiling Brackets



*Specify exact drop required from ceiling.*

### Angled Brackets



*The solution for tight and awkward locations.*

## MINIMUM & MAXIMUM BRACKET PROJECTIONS

Dimensions outside of these stated min/max projections may still be possible but will generate a design charge per drawing. See pricelist for details

Size	Type	Standard Projection(s)	Minimum Special Projection	Maximum Special Projection
H27mm (1 1/16")	Side	100mm (4")	95mm (3 3/4")	200mm (8")
H27mm (1 1/16")	Mid	100mm (4")	95mm (3 3/4")	200mm (8")

The information below shows the relationship between the track, brackets and gliders/rollers. This will enable the correlation between track heights and curtain drops to be easily calculated.

### SINGLE SYSTEM - H27mm (1 1/16")

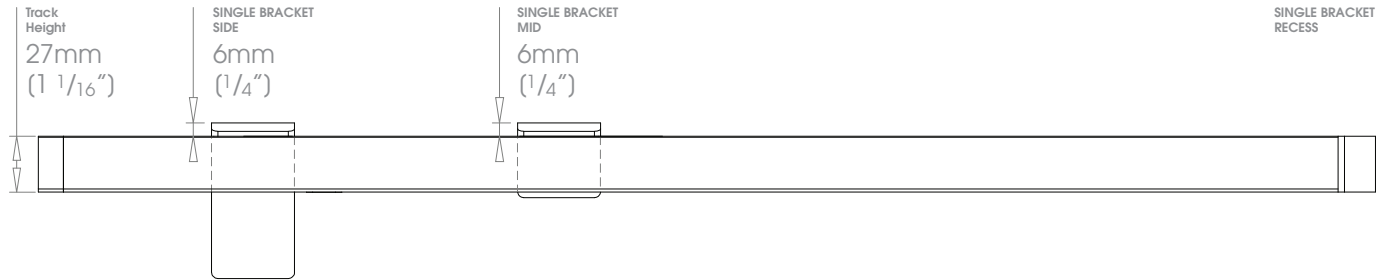

### DOUBLE SYSTEM - FRONT H27mm (1 1/16") BACK H27mm (1 1/16")

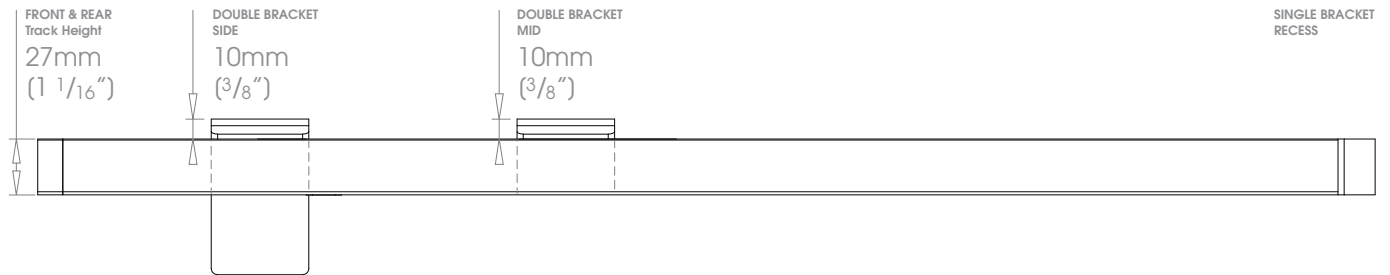

### PIN HOOK MEASUREMENT *From bottom of the track*

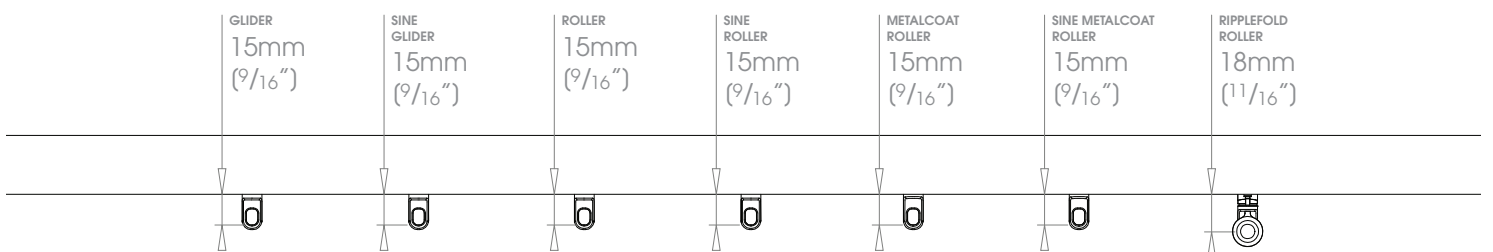

### CONFIGURATION

A looped driving belt runs around the motor and along the track. This is attached to the pilot header which in turn is attached to the lead glider/roller.

#### **SINGLE MOTOR - *Single Stack*** ▶

On single stack systems the motor is always positioned on the stacking side. Allowing the motor to be hidden behind the curtain.



---

#### **SINGLE MOTOR - *Pair Stack*** ▶◀

Pair stack curtains can have the motor positioned at either end of the track. Curtains must be equal in length



---

#### **TWIN MOTOR - *Pair Stack*** ▶◀

Twin Motor systems have the motor positioned at both ends of the track. And are pair stack curtains only which can be different in length



### MOTOR POSITIONING

Mains powered motor's needs to be positioned on same side of the window as the power supply.

Wiring diagrams are available on request

Motorised systems are unsuitable for use outdoors or in damp environments such as shower rooms and bathrooms.

#### ⚡ MAINS POWERED SYSTEMS

#### 🔋 BATTERY POWERED SYSTEMS SOMFY® MOVELITE & IRISMO ONLY

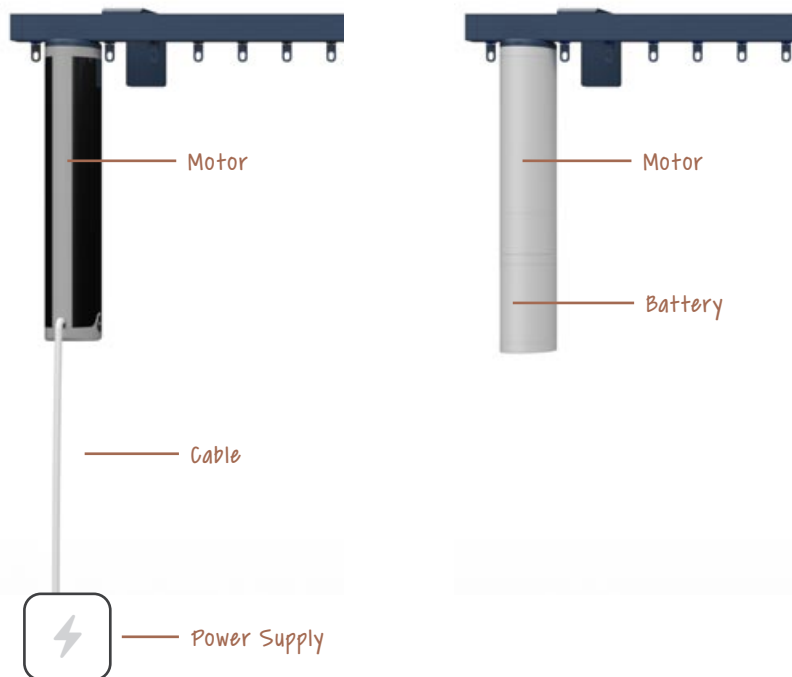

#### LEFT HAND MOTOR



#### RIGHT HAND MOTOR



#### TWIN MOTORS



### LUTRON CONFIGURATION

Motor adaptors are supplied to match system colour. Motors can be positioned either perpendicular or in-line with the track. A gliding option is assembled between the motor adaptor and the end of the track, serving as a curtain hook point.

#### MOTOR END - PERPENDICULAR *Default*

As standard motor position is set perpendicular to the track. Minimising non functioning gliding area. Optimal for Sine and Ripplefold headings.

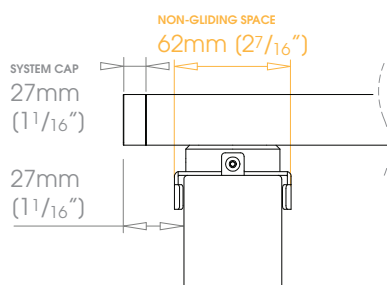
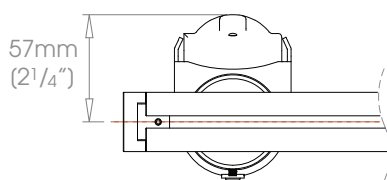

#### MOTOR END - IN-LINE *Option*

As an option motor position can be set in-line with the track. Allowing for the system to sit closer to the wall where space is limited. This increases the non-functioning gliding area.

Not recommended for Sine and Ripplefold headings.

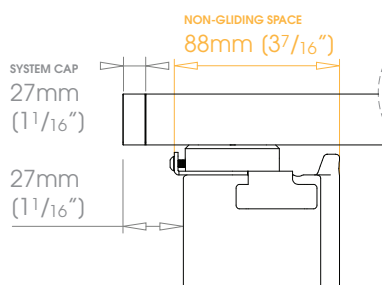
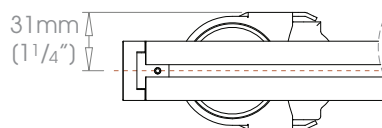

#### RETURN END - SINGLE STACK ▶

Single stack systems utilise a smaller return cartridge embedded in the profile. Master carriers are designed to allow curtains travel to travel to the end of the system.

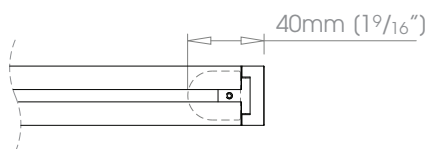

#### RETURN END - PAIR STACK ▶◀

Pair stack systems use the standard return cartridge embedded within the profile. A gliding option is assembled between the cartridge and the end of the track, serving as a curtain hook point.

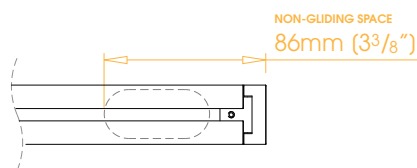

#### TWIN END - PAIR STACK ▶◀

Twin systems are supplied in a minimum of two sections, with an internal return cartridge, in the end of each section.

Mid brackets can be fitted on join

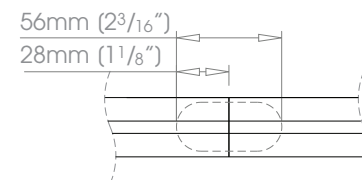

### SOMFY CONFIGURATION

Motor adaptors are supplied to match system colour. Motors can be positioned either perpendicular or in-line with the track. A gliding option is assembled between the motor adaptor and the end of the track, serving as a curtain hook point.

#### MOTOR END - PERPENDICULAR *Default*

As standard motor position is set perpendicular to the track. Minimising non functioning gliding area. Optimal for Sine and Ripplefold headings.

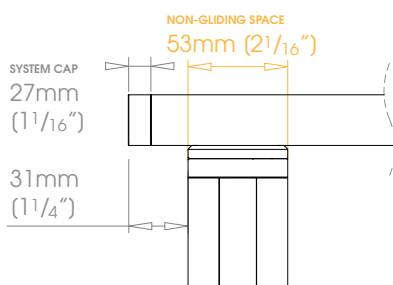
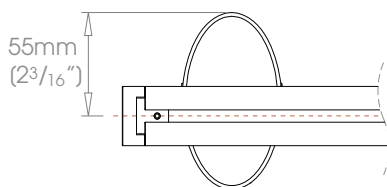

#### MOTOR END - IN-LINE *Option*

As an option the motor adaptor position can be set in-line with the track. Allowing for the system to sit closer to the wall where space is limited. This increases the non-functioning gliding area.

Not recommended for Sine and Ripplefold headings.

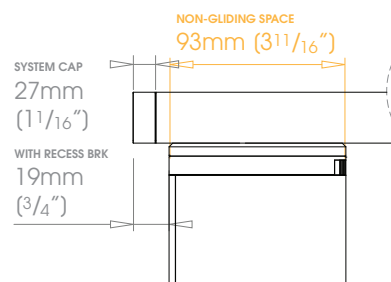
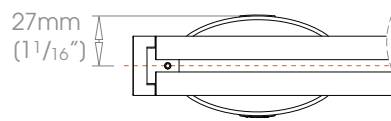

#### RETURN END - SINGLE STACK ▶

Single stack systems utilise a smaller return cartridge embedded in the profile. Master carriers are designed to allow curtains travel to travel to the end of the system.

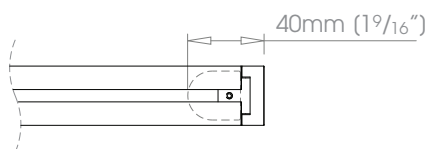

#### RETURN END - PAIR STACK ▶◀

Pair stack systems use the standard return cartridge embedded within the profile. A gliding option is assembled between the cartridge and the end of the track, serving as a curtain hook point.

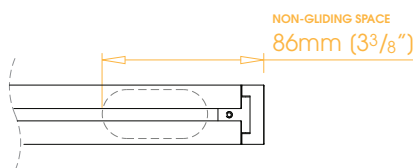

#### TWIN END - PAIR STACK ▶◀

Twin systems are supplied in a minimum of two sections, with an internal return cartridge, in the end of each section.

Mid brackets can be fitted on join

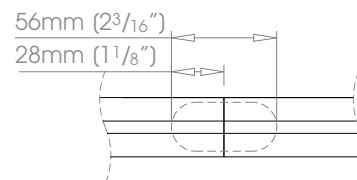

### SILENT GLISS CONFIGURATION

Motor adaptors are supplied to match system colour. Motors can be positioned either perpendicular or in-line with the track. A gliding option is assembled between the motor adaptor and the end of the track, serving as a curtain hook point.

#### MOTOR END - PERPENDICULAR *Default*

As standard motor position is set perpendicular to the track. Minimising non functioning gliding area. Optimal for Sine and Ripplefold headings.

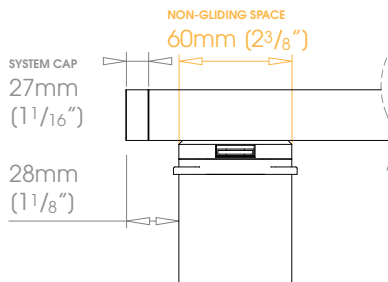
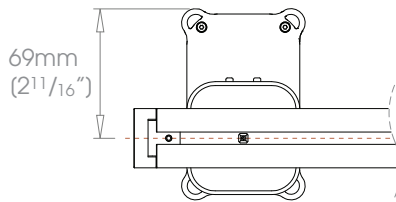

#### MOTOR END - IN-LINE *Option*

As an option motor position can be set in-line with the track. Allowing for the system to sit closer to the wall where space is limited. This increases the non-functioning gliding area.

Not recommended for Sine and Ripplefold headings.

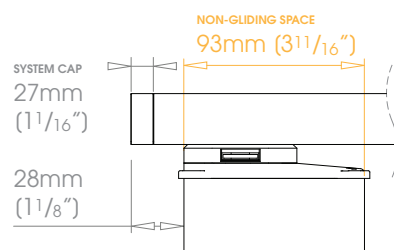
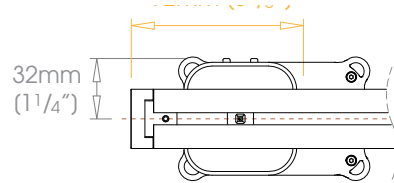

#### RETURN END - SINGLE STACK ▶

Single stack systems utilise a compact return cartridge embedded in the profile. Master carriers are designed to allow curtains travel to travel to the end of the system.

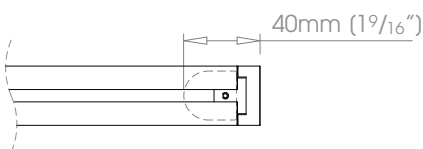

#### RETURN END - PAIR STACK ▶◀

Pair stack systems use the standard return cartridge embedded within the profile. A gliding option is assembled between the cartridge and the end of the track, serving as a curtain hook point.

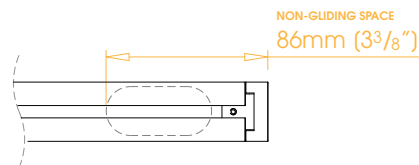

#### TWIN END - PAIR STACK ▶◀

Twin systems are supplied in a minimum of two sections, with a compact return cartridge, in the end of each section.

Mid brackets can be fitted on join

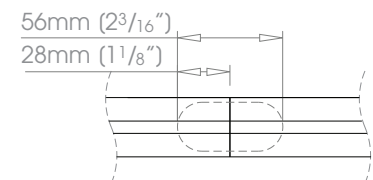

### GLIDER/ROLLER ACCESS

Gliding options can be added/removed by removing the access plate

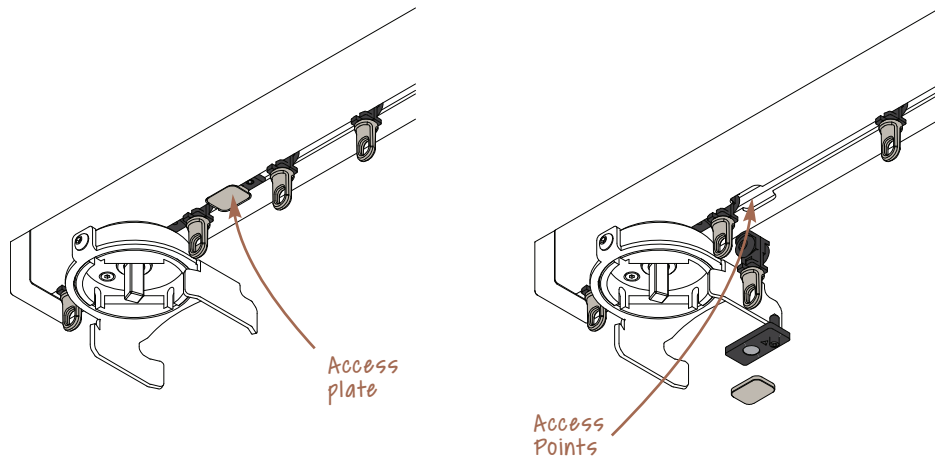

Systems will be supplied as per the diagrams below.

### LINEAR TRACK SYSTEMS

*Gliders • Rollers • Metalcoat Rollers*



#### SINGLE MOTOR - *Single Stack* ▶

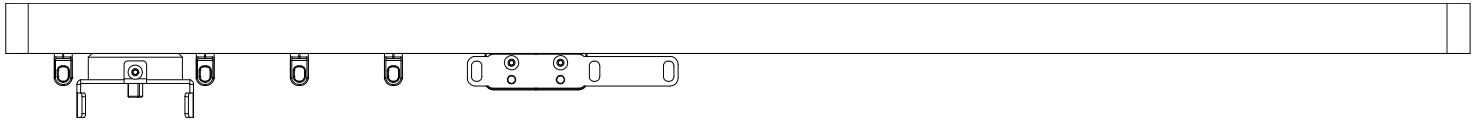

**SUPPLIED WITH**

1x Motor Adaptor & Cartridge • 1x Compact Return Cartridge • 1x Single stack Overlap Arm

#### SINGLE MOTOR - *Pair Stack* ▶◀

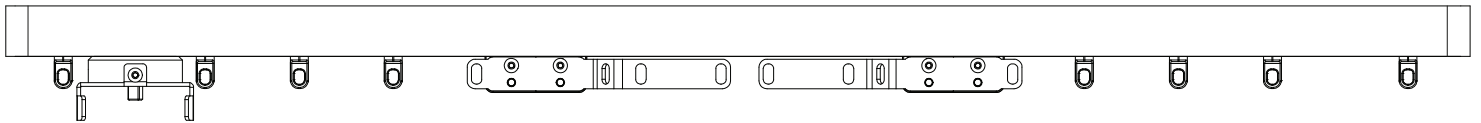

**SUPPLIED WITH**

1x Motor Adaptor & Cartridge • 1x Return Cartridge • 2x Pair stack Overlap Arm

#### TWIN MOTOR - *Pair Stack* ▶◀

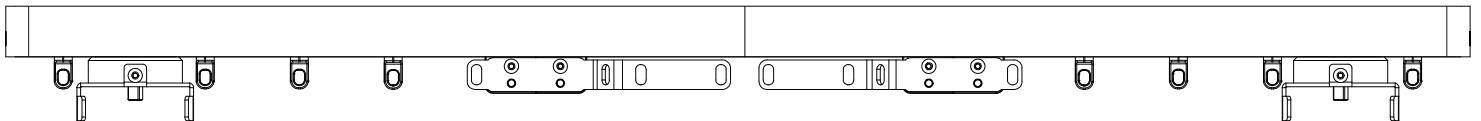

**SUPPLIED WITH**

2x Motor Adaptor & Cartridge • 2x Compact Return Cartridge • 2x Pair stack Overlap Arm



For Specification info on Overlap master carrier see page 27.

Systems will be supplied as per the diagrams below.

### LINEAR TRACK SYSTEMS

*Sine Gliders • Sine Rollers • Metalcoat Sine Rollers*

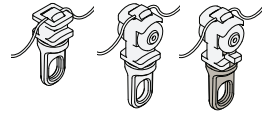

#### SINGLE MOTOR - *Single Stack* ▶

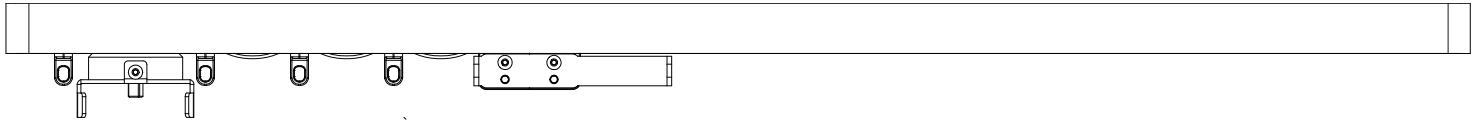

**SUPPLIED WITH**

1x Motor Adaptor & Cartridge • 1x Compact Return Cartridge • 1x Single stack Sine Arm

#### SINGLE MOTOR - *Pair Stack* ▶◀

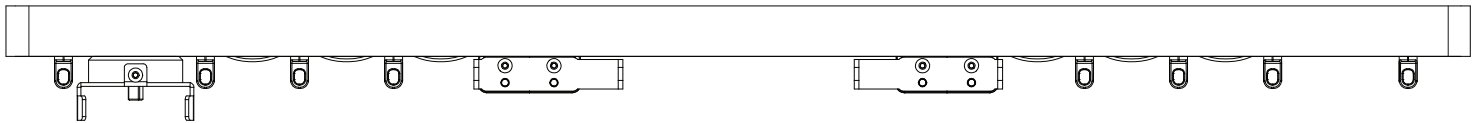

**SUPPLIED WITH**

1x Motor Adaptor & Cartridge • 1x Return Cartridge • 2x Pair stack Sine Butt Arm

#### TWIN MOTOR - *Pair Stack* ▶◀

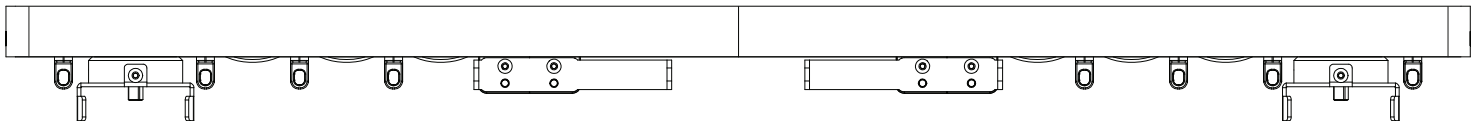

**SUPPLIED WITH**

2x Motor Adaptor & Cartridge • 2x Compact Return Cartridge • 2x Single stack Sine Arm



For Specification info on Sine master carrier see page 28

Systems will be supplied as per the diagrams below.

### LINEAR TRACK SYSTEMS

*Metalcoat Ripplefold Rollers*

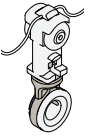

#### SINGLE MOTOR - *Single Stack* ▶

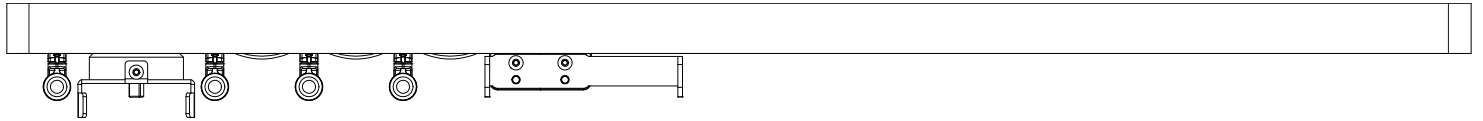

**SUPPLIED WITH**

1x Motor Adaptor & Carriage • 1x Compact Return Carriage • 1x Single stack Ripplefold Arm

#### SINGLE MOTOR - *Pair Stack* ▶◀

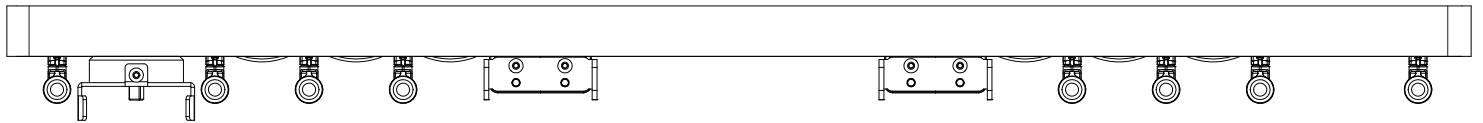

**SUPPLIED WITH**

1x Motor Adaptor & Carriage • 1x Return Carriage • 2x Pair stack Ripplefold Butt Arm

#### TWIN MOTOR - *Pair Stack* ▶◀

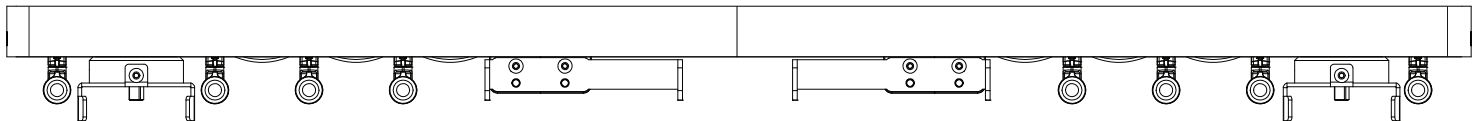

**SUPPLIED WITH**

2x Motor Adaptor & Carriage • 2x Compact Return Carriage • 2x Single stack Ripplefold Arm



For Specification info on Ripplefold master carrier see page 29

**STACK SIZES**

This is the area where the curtains hang against the wall when they are pulled open. by covering the wall and not the glass, during the day, it allows more light into the room. Allow approximately 30% of the length of the track for curtain stacking, very full curtains (e.g. pencil pleat) will need more space than flatter ones. lined and interlined curtains will also require more stacking space than unlined.

Single Stack ▶



Pair Stack ▶◀



### STANDARD HEADINGS



#### GLIDERS

*Gliders are suitable for most installations*

One glider is specified for every 100mm (4")

**Glider Colour Options:** Gypsum • Anthracite

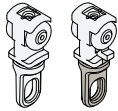

#### ROLLERS • METALCOAT ROLLERS

*Rollers are preferred for heavy drapery & Systems with joins*

One roller is specified for every 100mm (4")

**Roller Colour Options:** Gypsum • Anthracite

**Metalcoat Colour Options:** System Colour ☉

**STANDARD**  
Fullness 1.5

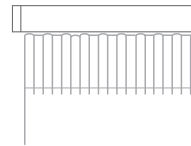

**PINCH PLEAT**  
Fullness 2.0

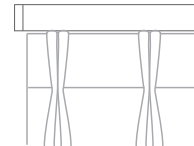

**PENCIL PLEAT**  
Fullness 2.5 (Heavy)  
Fullness 2.5 (Voiles)

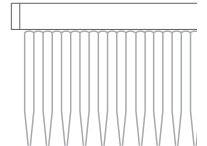

Pencil pleats will have a larger stack back and performance may be reduced

### SINE HEADINGS

Sine headings are a simple S folded heading system consisting of rollers spaced by a cord and a special pocketed header tape that is sewn onto a flat panel curtain.track. it offers an elegant, contemporary look.

- Ideal for both residential and commercial settings.
- Drapery is constructed using special pocketed header tape that is sewn onto a flat panel curtain
- Hooks are fitted to header tape at a set spacing shown below creating the ripple effect
- Fullness can be adjusted by changing the hook spacing.

SINE  
Fullness 2.3

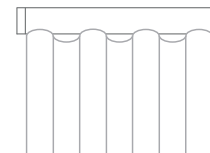

### FABRIC SUITABILITY

There is no standard test that will indicate whether a fabric is suitable for wave style. However, experience suggests it is normally suitable for:

✓ Voiles • Lined cotton • Interlined Silk • Blackout lining

The soft curves of Sine do not lend themselves to:

✗ Stiff fabrics • Heavy embroidery • Irregular vertical stripes • Metallic threads



### SINE GLIDERS

*Gliders are suitable for most installations*

**Sine Pitch:** 80mm (3 1/8")

**Sine Glider Colour Options:** Gypsum - White Cord • Anthracite - White Cord

Glider-Cord Spacing	Curtain Hook Spacing	Approx. Curtain Fullness	Stack Depth per 1M (39 3/8") of track	Min Bracket Projection
80mm (3 1/8")	160mm (6 3/16")	2.3	180mm (7 1/16")	100mm (4")

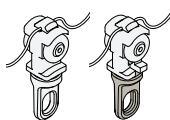

### SINE ROLLERS • METALCOAT SINE ROLLERS

*Rollers are preferred for heavy drapery & Systems with joins*

**Sine Pitch:** 60mm (2 3/8") • 80mm (3 1/8")

**Sine Roller Colour Options:** Gypsum - White Cord • Anthracite - Black Cord

**Metalcoat Sine Roller Colour Options:** System Colour ☺

Roller-Cord Spacing	Curtain Hook Spacing	Approx. Curtain Fullness	Stack Depth per 1M (39 3/8") of track	Min Bracket Projection
60mm (2 3/16")	120mm (4 3/4")	2.3	230mm (9 1/16")	100mm (4")
80mm (3 1/8")	160mm (6 3/16")	2.3	180mm (7 1/16")	100mm (4")

### RIPPLEFOLD HEADING

Ripplefold pleat style is named for the soft, consistent ripples created by the drapery as it hangs from the track. It offers an elegant, contemporary look.

- Ideal for both residential and commercial settings.
- Drapery is constructed with snap tape (Graber®/Kirsch) that allows the drapery to be snapped directly to the auxiliary carriers on the track.
- Fullness of the drapery is determined by the spacing of the carriers in the track. the higher the fullness factor, the more full the draperies appear.
- 3 fullness factors are available

RIPPLEFOLD

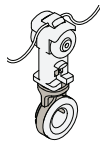
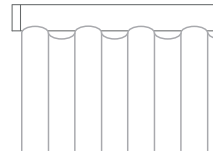

#### RIPPLEFOLD ROLLERS

*Rollers are preferred for heavy drapery & Systems with joins*

**Ripplefold® Fullness:** 80% • 100%

**Metalcoat Ripplefold® Roller Colour Options:** System Colour ☺

	Roller-Cord Spacing	Curtain Fullness	Stack Depth per 1M (39 7/8") of track	Min Bracket Projection
	60mm (2 3/8")	80%	270mm (10 5/8")	100mm (4")
	55mm (2 1/16")	100%	310mm (12 3/16")	100mm (4")

Different types of fabric have widely differing weights. The type of curtain heading used (see below) will determine the fullness of the fabric used: this can be anything from 1.5 x the width of the pole to 3.0 x pole width.

The chart below assumes 100% fullness (2.0 x width of the pole) the weights are approximate and can vary for many reasons. Always check the expected and final total curtain weight with the curtain maker. Based on 1200mm (48") fabric width

Curtain Type	Width↔/Drop↕	1m (3.5')	2m (7')	3m (10.5')	4m (14')	5m (16.5')	6m (20')
Print Cotton (Light)	1m (3.5')	0.8kg (1.8lb)	1.7kg (3.7lb)	2.5kg (5.5lb)	3.4kg (7.4lb)	4.2kg (9.2lb)	5.0kg (11.1lb)
	2m (7')	1.3kg (2.8lb)	2.5kg (5.5lb)	3.8kg (8.3lb)	5kg (11.1lb)	6.3kg (13.9lb)	7.6kg (16.6lb)
	3m (10')	1.7kg (3.7lb)	3.4kg (7.4lb)	5kg (11.1lb)	6.7kg (14.8lb)	8.4kg (18.5lb)	10kg (22lb)
Linen (Medium)	1m (3.5')	1.1kg (2.3lb)	2.1kg (4.6lb)	3.2kg (6.9lb)	4.2kg (9.2lb)	5.3kg (11.6lb)	6.3kg (13.9lb)
	2m (7')	1.6kg (3.5lb)	3.2kg (6.9lb)	4.7kg (10.4lb)	6.3kg (13.9lb)	7.9kg (17.3lb)	9.5kg (20.8lb)
	3m (10')	2.1kg (4.6lb)	4.2kg (9.2lb)	6.3kg (13.9lb)	8.4kg (18.5lb)	10.5kg (23.1lb)	12.6kg (27.7lb)
Velvet (Heavy)	1m (3.5')	1.5kg (3.2lb)	3.2kg (6.5lb)	4.4kg (9.7lb)	5.9kg (12.9lb)	7.4kg (16.2lb)	8.8kg (19.4lb)
	2m (7')	2.2kg (4.9lb)	4.4kg (9.7lb)	6.7kg (12.6lb)	8.8kg (19.4lb)	11kg (24.3lb)	13.2kg (22lb)
	3m (10')	2.9kg (6.5lb)	5.9kg (12.9lb)	8.8kg (19.4lb)	11.8kg (26lb)	14.7kg (32.2lb)	17.6kg (39lb)

Maximum weight recommendations for all standard curtain types using gliders & roller are defined to ensure safe and proper function of the system. These limits must be adhered to. See table below for details of all options.



Bends will considerably reduce the load bearing capability of any system.

### GLIDERS • SINE GLIDERS

Gliders One glider is specified for every 100mm (4").

Sine Gliders 80mm (3 1/8") spacing between the gliders.

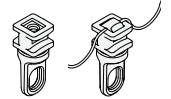

Motor Type	System Width	Straight		1 Bend Bay		2 Bend Bay		4 Bend Bay		Curved Bay	
		Single Motor Single Stack ▶ Pair Stack ▶◀	Twin Motor Pair Stack ▶◀	Single Motor Single Stack ▶ Pair Stack ▶◀	Twin Motor Pair Stack ▶◀	Single Motor Single Stack ▶ Pair Stack ▶◀	Twin Motor Pair Stack ▶◀	Twin Motor Pair Stack ▶◀	Single Motor Single Stack ▶ Pair Stack ▶◀	Twin Motor Pair Stack ▶◀	
⚡ LUTRON D105	6m (236 1/4")	27kg (60lb)	54kg (120lb)	20kg (43lb)	40kg (44lb)	⚠ Motor not suitable for system with multiple bends					
	12m (472 1/2")	—	64kg (140lb)	—	40kg (44lb)						
⚡ LUTRON D145	6m (236 1/4")	47kg (102lb)	94kg (204lb)	37kg (81lb)	73kg (162lb)	21kg (47lb)	43kg (94lb)	43kg (94lb)	21kg (47lb)	43kg (94lb)	
	12m (472 1/2")	—	94kg (204lb)	—	73kg (162lb)	—	43kg (94lb)	43kg (94lb)	—	43kg (94lb)	
⚡ LUTRON D175	6m (236 1/4")	67kg (149lb)	134kg (298lb)	50kg (111lb)	100kg (221lb)	46kg (102lb)	92kg (204lb)	92kg (204lb)	46kg (102lb)	92kg (204lb)	
	12m (472 1/2")	—	84kg (185lb)	—	100kg (221lb)	—	92kg (204lb)	92kg (204lb)	—	92kg (204lb)	
⚡ SOMFY GLYDEA ULTRA 60E	6m (236 1/4")	51kg (112lb)	102kg (224lb)	45kg (99lb)	90kg (198lb)	35kg (77lb)	70kg (154lb)	70kg (154lb)	35kg (77lb)	70kg (154lb)	
	12m (472 1/2")	—	102kg (224lb)	—	90kg (198lb)	—	70kg (154lb)	70kg (154lb)	—	70kg (154lb)	
⚡ SOMFY IRISMO 45 WF	6m (236 1/4")	45kg (99lb)	90kg (198lb)	38kg (84lb)	77kg (168lb)	26kg (56lb)	51kg (112lb)	51kg (112lb)	17kg (37lb)	34kg (75lb)	
	12m (472 1/2")	—	90kg (198lb)	—	90kg (198lb)	—	51kg (112lb)	51kg (112lb)	—	34kg (75lb)	
⚡ SOMFY MOVELITE 35	6m (236 1/4")	30kg (65lb)	60kg (131lb)	21kg (47lb)	43kg (94lb)	9kg (19lb)	17kg (37lb)	17kg (37lb)	9kg (19lb)	17kg (37lb)	
	12m (472 1/2")	—	60kg (131lb)	—	43kg (94lb)	—	17kg (37lb)	17kg (37lb)	—	17kg (37lb)	
⚡ SOMFY MOVELITE 35 WF	6m (236 1/4")	30kg (65lb)	60kg (131lb)	⚠ Motor not suitable for system with bends							
	12m (472 1/2")	—	60kg (131lb)								
⚡ SILENT GLISS 9060	6m (236 1/4")	38kg (84lb)	77kg (168lb)	30kg (65lb)	60kg (131lb)	26kg (56lb)	51kg (112lb)	51kg (112lb)	17kg (37lb)	34kg (75lb)	
	12m (472 1/2")	—	77kg (168lb)	—	60kg (131lb)	—	51kg (112lb)	51kg (112lb)	—	34kg (75lb)	

Maximum weight recommendations for all standard curtain types using gliders & roller are defined to ensure safe and proper function of the system. These limits must be adhered to. See table below for details of all options.

**!** Bends will considerably reduce the load bearing capability of any system.

### ROLLERS • SINE ROLLERS METALCOAT ROLLERS • METALCOAT SINE ROLLERS • METALCOAT RIPPLEFOLD ROLLERS

Rollers One roller is specified for every 100mm (4").

Sine Rollers 60mm (2 3/8") • 80mm (3 1/8") spacing between the rollers.

Ripplefold Rollers Fullness options 80% • 100%

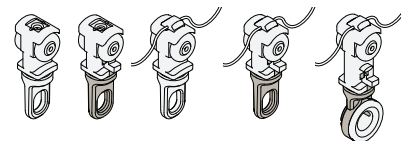

Motor Type	System Width	Straight	Straight	1 Bend Bay	1 Bend Bay	2 Bend Bay	2 Bend Bay	4 Bend Bay	Curved Bay	Curved Bay
		Single Motor Single Stack ▶ Pair Stack ▶◀	Twin Motor Pair Stack ▶◀	Single Motor Single Stack ▶ Pair Stack ▶◀	Twin Motor Pair Stack ▶◀	Single Motor Single Stack ▶ Pair Stack ▶◀	Twin Motor Pair Stack ▶◀	Twin Motor Pair Stack ▶◀	Twin Motor Pair Stack ▶◀	Single Motor Single Stack ▶ Pair Stack ▶◀
LUTRON D105	6m (236 1/4")	32kg (70lb)	64kg (140lb)	23kg (50lb)	46kg (100lb)	<b>!</b> Motor not suitable for system with multiple bends				
	12m (472 1/2")	—	64kg (140lb)	—	46kg (100lb)					
LUTRON D145	6m (236 1/4")	55kg (120lb)	110kg (240lb)	43kg (95lb)	86kg (190lb)	25kg (55lb)	50kg (110lb)	50kg (110lb)	25kg (55lb)	50kg (110lb)
	12m (472 1/2")	—	110kg (240lb)	—	86kg (190lb)	—	50kg (110lb)	50kg (110lb)	—	50kg (110lb)
LUTRON D175	6m (236 1/4")	79kg (175lb)	158kg (350lb)	59kg (130lb)	118kg (260lb)	54kg (120lb)	108kg (240lb)	108kg (240lb)	54kg (120lb)	108kg (240lb)
	12m (472 1/2")	—	84kg (185lb)	—	118kg (260lb)	—	108kg (240lb)	108kg (240lb)	—	108kg (240lb)
SOMFY GLYDEA ULTRA 60E	6m (236 1/4")	60kg (132lb)	120kg (264lb)	45kg (99lb)	90kg (198lb)	35kg (77lb)	70kg (154lb)	70kg (154lb)	35kg (77lb)	70kg (154lb)
	12m (472 1/2")	—	120kg (264lb)	—	90kg (198lb)	—	70kg (154lb)	70kg (154lb)	—	70kg (154lb)
SOMFY IRISMO 45 WF	6m (236 1/4")	45kg (99lb)	90kg (198lb)	45kg (99lb)	90kg (198lb)	30kg (66lb)	60kg (132lb)	60kg (132lb)	20kg (44lb)	40kg (88lb)
	12m (472 1/2")	—	90kg (198lb)	—	90kg (198lb)	—	60kg (132lb)	60kg (132lb)	—	40kg (88lb)
SOMFY MOVELITE 35	6m (236 1/4")	35kg (77lb)	70kg (154lb)	25kg (55lb)	50kg (110lb)	10kg (22lb)	20kg (44lb)	20kg (44lb)	10kg (22lb)	20kg (44lb)
	12m (472 1/2")	—	70kg (154lb)	—	—	—	20kg (44lb)	20kg (44lb)	—	20kg (44lb)
SOMFY MOVELITE 35 WF	6m (236 1/4")	35kg (77lb)	70kg (154lb)	<b>!</b> Motor not suitable for system with bends						
	12m (472 1/2")	—	70kg (154lb)							
SILENT GLISS 9060	6m (236 1/4")	45kg (99lb)	90kg (198lb)	35kg (77lb)	70kg (154lb)	30kg (66lb)	60kg (132lb)	60kg (132lb)	20kg (44lb)	40kg (88lb)
	12m (472 1/2")	—	90kg (198lb)	—	70kg (154lb)	—	60kg (132lb)	60kg (132lb)	—	40kg (88lb)

Master carriers are composed of a polymer body, and a metal arm.  
 The polymer body is supplied in either Gypsum or Anthracite complement the system colour (see page 41 for details).  
 The metal arms are coated to match the system.

### OVERLAP ARM - *Single Stack* ▶

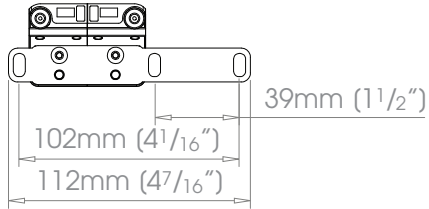

Supplied on single stack systems  
 with Gliders/Rollers



### OVERLAP ARM - *Pair Stack* ▶◀

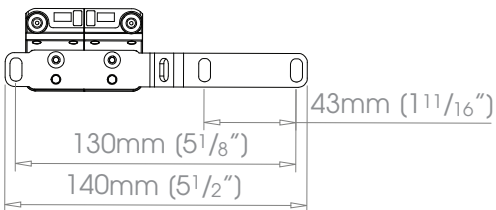

Supplied on pair stack systems  
 with Gliders/Rollers

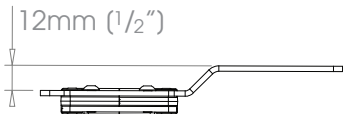

Master carriers are composed of a polymer body, and a metal arm.  
 The polymer body is supplied in either Gypsum or Anthracite complement the system colour (see page 41 for details).  
 The metal arms are coated to match the system.

### SINE ARM - Single Stack ▶

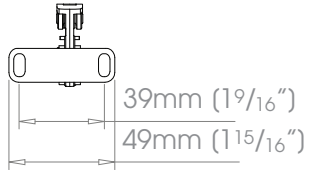
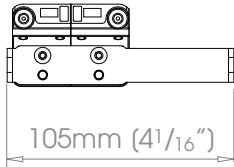

Supplied on single stack systems  
with Sine Gliders/Rollers

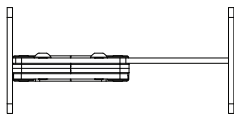

### 60mm (2 3/8 inches) SINE BUTT ARM - Pair Stack ▶◀

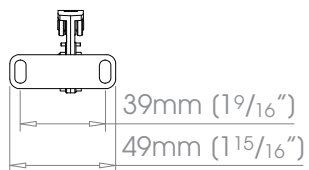
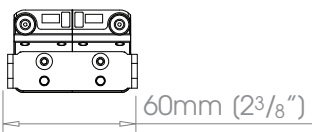

Supplied on pair stack systems  
with Sine Rollers

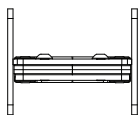

### 80mm (3 1/8 inches) SINE BUTT ARM - Pair Stack ▶◀

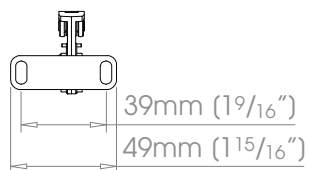
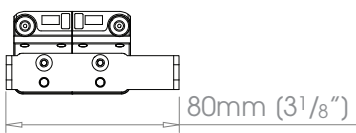

Supplied on pair stack systems  
with Sine Gliders/Rollers

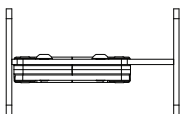

Master carriers are composed of a polymer body, and a metal arm.  
 The polymer body is supplied in either Gypsum or Anthracite complement the system colour (see page 41 for details).  
 The metal arms are coated to match the system.

### RIPPLEFOLD ARM - *Single Stack* ▶

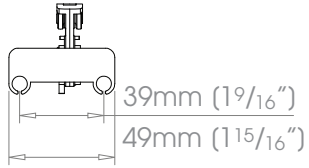
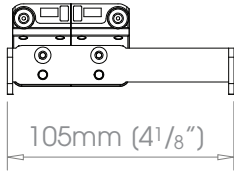

Supplied on single stack systems  
with Ripplefold Rollers

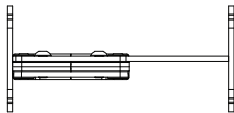

### RIPPLEFOLD BUTT ARM - *Pair Stack* ▶◀

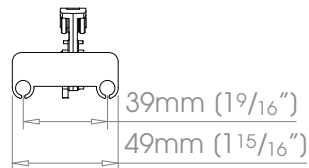
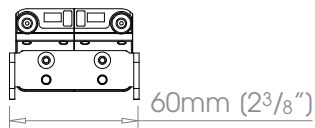

Supplied on pair stack systems  
with Ripplefold Rollers

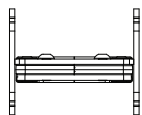

Master carriers are composed of a polymer body, and a metal arm.  
 The polymer body is supplied in either Gypsum or Anthracite complement the system colour (see page 41 for details).  
 The metal arms are coated to match the system.

### OPTIONAL OVERLAP ARM - *Single Stack* ▶

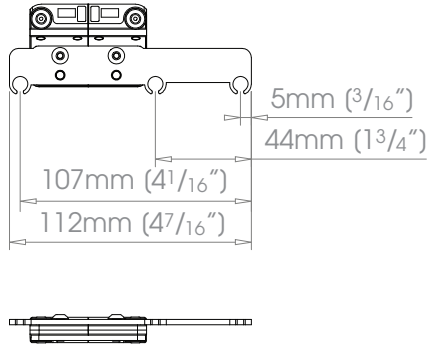

Can be supplied as an option on single stack Ripplefold systems.  
 Subject to surcharge

### OPTIONAL OVERLAP ARM - *Pair Stack* ▶◀

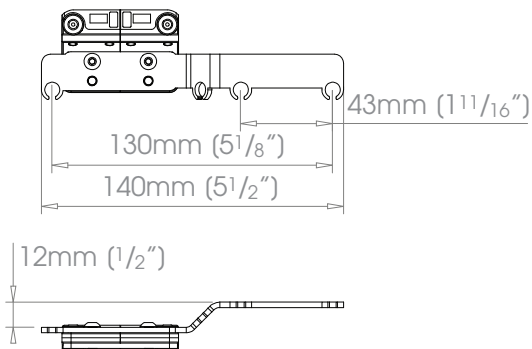

Can be supplied as an option on pair stack Ripplefold systems.  
 Subject to surcharge



All tracks and components may be specified in this stunning palette of colours and finishes, with a choice of coat options throughout.

### SHADES

A superb selection of opaque colours, all available in a choice of Matte, Satin or Gloss finish.

#### COAT OPTIONS

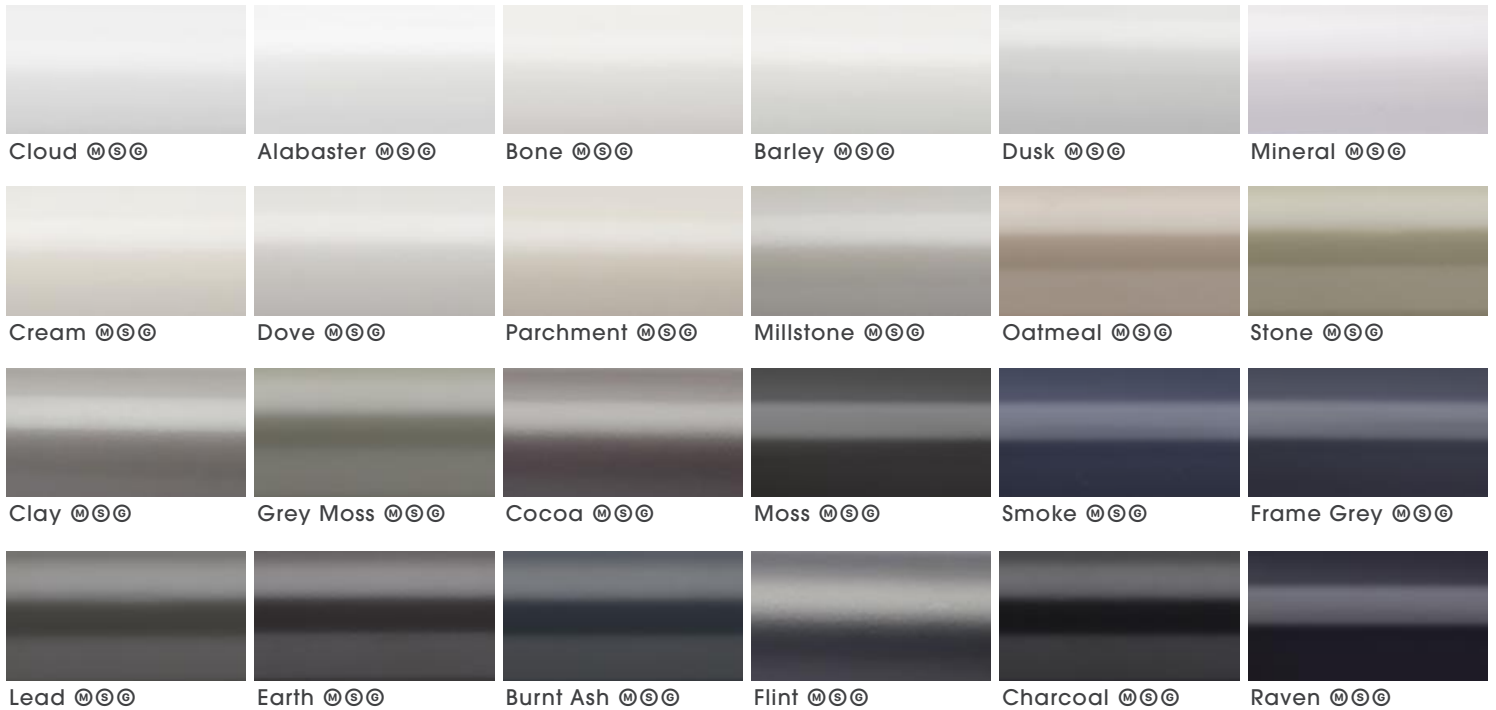

### METALLICS

High metallic fleck coatings with all available in Satin and Gloss sheen levels.

#### COAT OPTIONS

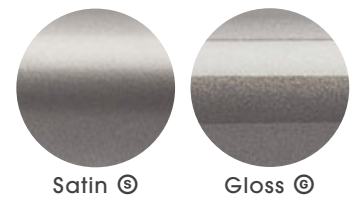

## ANODICS

A flat metal colour group, with an anodised style surface texture.

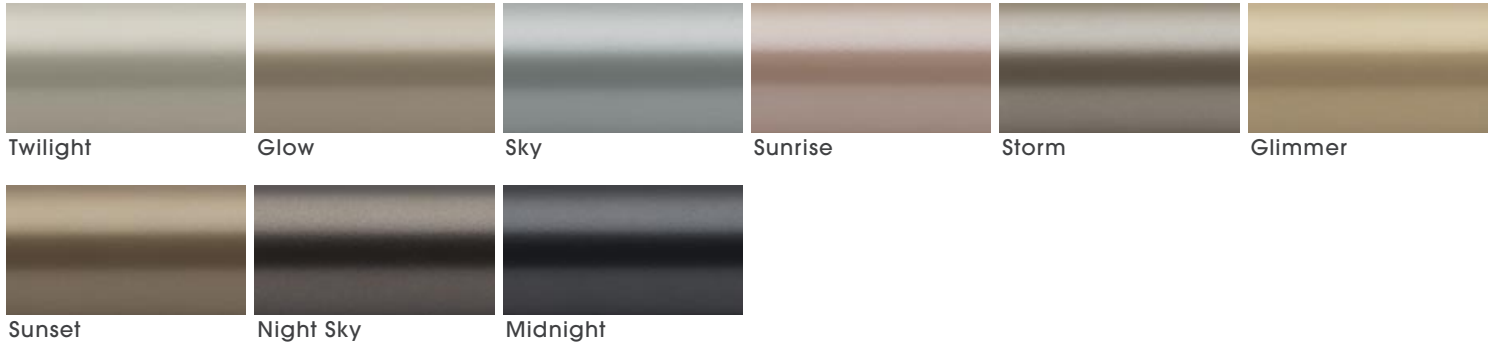

## ORGANICS

A textured finish, inspired by nature.



## CERAMICS

Finished with ceramic Cerakote for industry leading protection and a flawless finish that endures daily life.

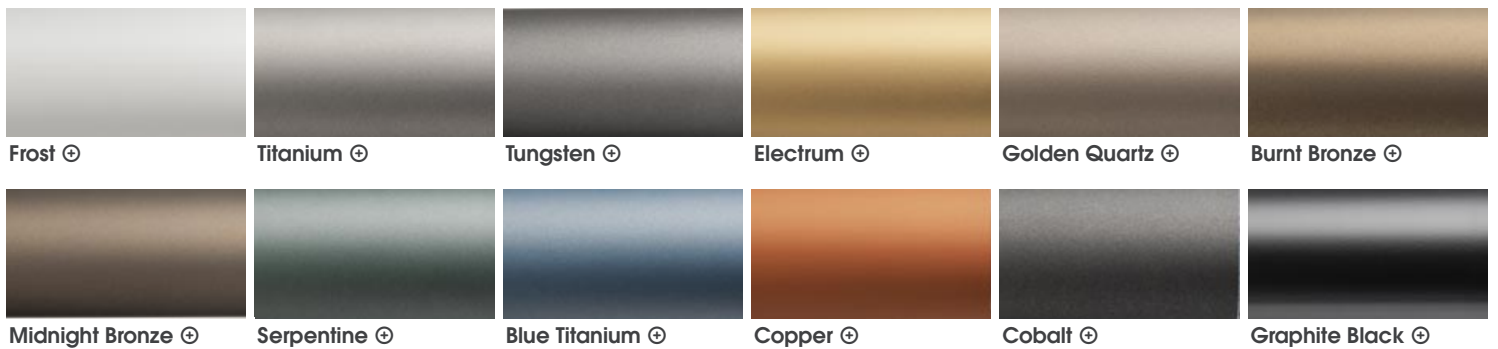

### CUSTOM FINISHES

Can be specified from RAL K7 finish chart, subject to a per colour upcharge.  
Which covers up to five tracks. See price list for further details



---

### COLOUR MATCHING

A colour matching service is offered, to match your scheme of fittings perfectly . See price list for further details

Metalcoat Rollers will be supplied with bodies in either Gypsum or Anthracite bodies to compliment the chosen finish.

See table below **Coat Options** Matte® • Satin® • Gloss®

### SHADES • METALLICS • ANODICS • ORGANICS

System Finish	Gypsum 	Anthracite 
Alabaster®®®	✓	
Antique Brass®®		✓
Ash Stone		✓
Barley®®®	✓	
Bone®®®	✓	
Burnt Ash®®®		✓
Bronzed®®		✓
Champagne®®		✓
Charcoal®®®		✓
Clay®®®		✓
Cloud®®®	✓	
Cocoa®®®		✓
Cognac®®		✓
Cream®®®	✓	
Dove®®®	✓	
Dusk®®®	✓	
Earth®®®		✓
Flint®®®		✓
Frame Grey®®®		✓
Glimmer		✓
Glow		✓
Gold®®		✓
Grey Moss®®®		✓
Gunmetal®®		✓
Iron		✓
Lead®®®		✓
Midnight		✓
Millstone®®®		✓
Mineral®®®	✓	
Moss®®®		✓
Night Sky		✓
Oatmeal®®®		✓
Obsidian		✓
Parchment®®®	✓	
Pewter®®		✓
Platinum®®		✓
Raven®®®		✓
Sand Stone		✓
Sky		✓
Smoke®®®		✓
Stone®®®		✓
Storm		✓
Sunrise		✓
Sunset		✓
Twilight		✓

### CERAMICS

System Finish	Gypsum 	Anthracite 
Blue Titanium		✓
Burnt Bronze		✓
Cobalt		✓
Copper		✓
Electrum		✓
Frost	✓	
Golden Quartz		✓
Graphite Black		✓
Midnight Bronze		✓
Serpentine		✓
Titanium		✓
Tungsten		✓





**FINISHES**

Coat Options  
Matte ⊕  
Satin ⊕  
Gloss ⊕

- Shades** ⊕⊕⊕ Alabaster • Barley • Bone • Burnt Ash • Charcoal • Clay • Cloud • Cocoa • Cream • Dove • Dusk • Earth • Flint • Frame Grey • Grey Moss  
Lead • Millstone • Mineral • Moss • Oatmeal • Parchment • Raven • Smoke • Stone
- Metallics** ⊕⊕⊕ Antique Brass • Bronzed • Champagne • Cognac • Gold • Gunmetal • Pewter • Platinum  
**Anodics** ⊕⊕⊕ Glimmer • Glow • Midnight • Night Sky • Sky • Storm • Sunrise • Sunset • Twilight
- Organics** ⊕⊕⊕ Ash Stone • Iron • Obsidian • Sand Stone
- Ceramics** ⊕⊕⊕ Available at +50% the cost of the standard finish | Blue Titanium • Burnt Bronze • Cobalt • Copper • Electrum • Frost • Golden Quartz  
Graphite Black • Midnight Bronze • Serpentine • Titanium • Tungsten

h27mm (1 1/16") - Left Hand Motor

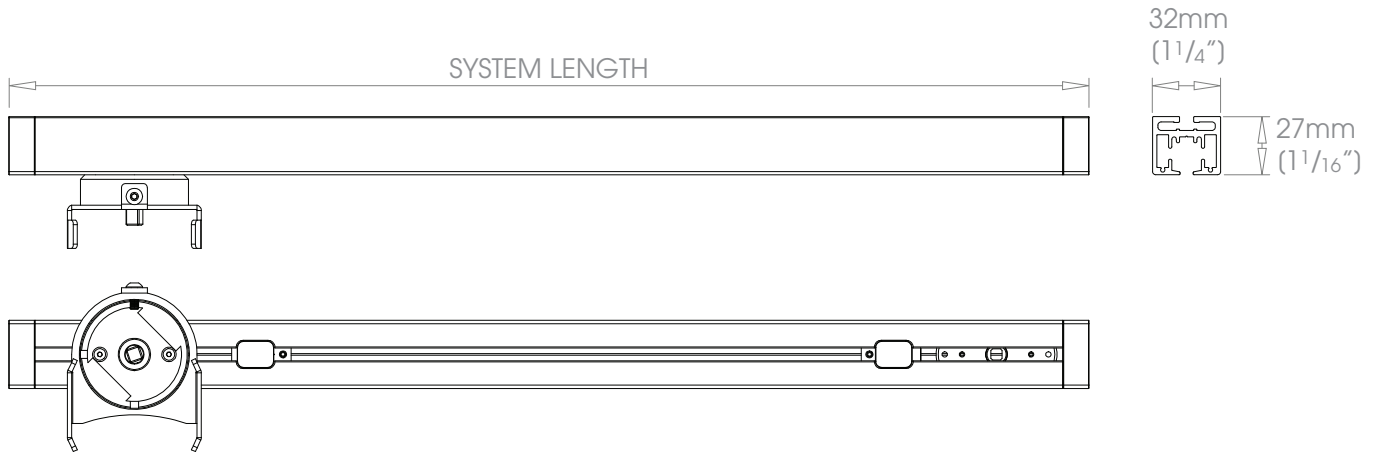

**Glider Options**

SINGLE STACK ▶ • PAIR STACK ▶◀



**GLIDER**  
Colour options:  
Gypsum • Anthracite



**SINE GLIDER**  
Colour options:  
Gypsum • Anthracite

Sine Pitch:  
80mm (3 1/8")

**Roller Options**

SINGLE STACK ▶ • PAIR STACK ▶◀



**ROLLER**  
Colour options:  
Gypsum • Anthracite



**SINE ROLLER**  
Colour options:  
Gypsum • Anthracite

Sine Pitch:  
60mm (2 3/8") • 80mm (3 1/8")



**METALCOAT ROLLER**  
Colour options:  
System Colour⊕



**METALCOAT SINE ROLLER**  
Colour options:  
System Colour⊕

Sine Pitch:  
60mm (2 3/8") • 80mm (3 1/8")



**METALCOAT RIPPLEFOLD ROLLER**  
Colour options:  
System Colour⊕

Fullness:  
80% • 100%



**FINISHES**

Coat Options

- Matte ☉
- Satin ☉
- Gloss ☉

- Shades** ☉☉☉
- Metallics** ☉☉
- Anodics** ☉☉
- Organics** ☉☉
- Ceramics** ☉☉

Alabaster • Barley • Bone • Burnt Ash • Charcoal • Clay • Cloud • Cocoa • Cream • Dove • Dusk • Earth • Flint • Frame Grey • Grey Moss  
 Lead • Millstone • Mineral • Moss • Oatmeal • Parchment • Raven • Smoke • Stone  
 Antique Brass • Bronzed • Champagne • Cognac • Gold • Gunmetal • Pewter • Platinum  
 Glimmer • Glow • Midnight • Night Sky • Sky • Storm • Sunrise • Sunset • Twilight  
 Ash Stone • Iron • Obsidian • Sand Stone  
*Available at +50% the cost of the standard finish* | Blue Titanium • Burnt Bronze • Cobalt • Copper • Electrum • Frost • Golden Quartz  
 Graphite Black • Midnight Bronze • Serpentine • Titanium • Tungsten

h27mm (1 1/16") - Right Hand Motor

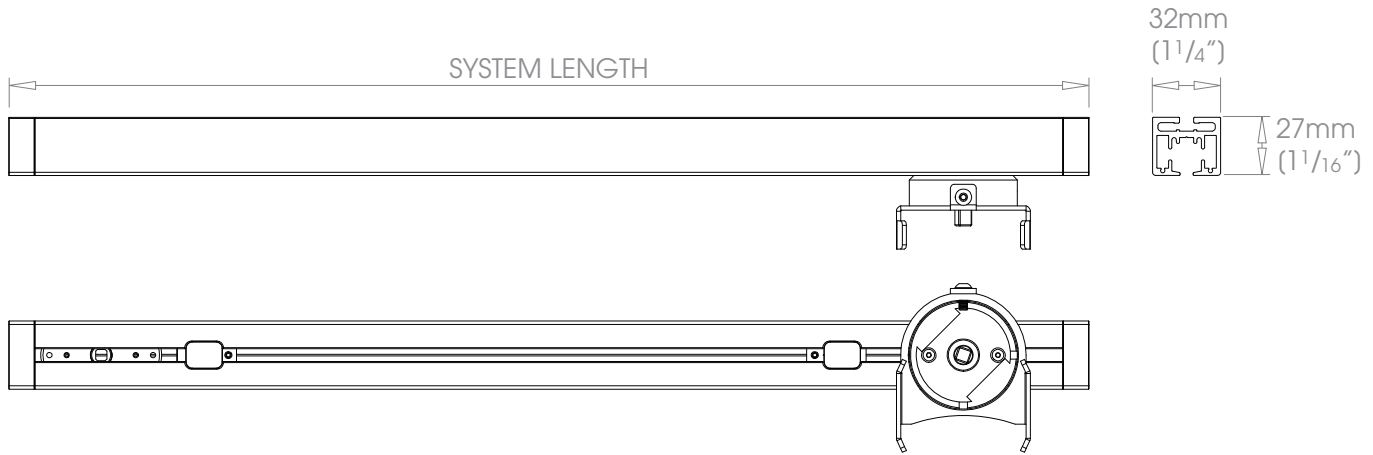

**Glider Options**

SINGLE STACK ▶ • PAIR STACK ▶◀



**GLIDER**  
 Colour options:  
 Gypsum • Anthracite



**SINE GLIDER**  
 Colour options:  
 Gypsum • Anthracite

Sine Pitch:  
 80mm (3 1/8")

**Roller Options**

SINGLE STACK ▶ • PAIR STACK ▶◀



**ROLLER**  
 Colour options:  
 Gypsum • Anthracite



**SINE ROLLER**  
 Colour options:  
 Gypsum • Anthracite

Sine Pitch:  
 60mm (2 3/8") • 80mm (3 1/8")



**METALCOAT ROLLER**  
 Colour options:  
 System Colour☉



**METALCOAT SINE ROLLER**  
 Colour options:  
 System Colour☉

Sine Pitch:  
 60mm (2 3/8") • 80mm (3 1/8")



**METALCOAT RIPPLEFOLD ROLLER**  
 Colour options:  
 System Colour☉

Fullness:  
 80% • 100%



**FINISHES**

Coat Options  
Matte Ⓞ  
Satin Ⓞ  
Gloss Ⓞ

- Shades** ⓄⓄⓄ Alabaster • Barley • Bone • Burnt Ash • Charcoal • Clay • Cloud • Cocoa • Cream • Dove • Dusk • Earth • Flint • Frame Grey • Grey Moss  
Lead • Millstone • Mineral • Moss • Oatmeal • Parchment • Raven • Smoke • Stone  
**Metallics** ⓄⓄ Antique Brass • Bronzed • Champagne • Cognac • Gold • Gunmetal • Pewter • Platinum  
**Anodics** ⓄⓄ Glimmer • Glow • Midnight • Night Sky • Sky • Storm • Sunrise • Sunset • Twilight  
**Organics** Ash Stone • Iron • Obsidian • Sand Stone  
**Ceramics** Available at +50% the cost of the standard finish | Blue Titanium • Burnt Bronze • Cobalt • Copper • Electrum • Frost • Golden Quartz  
Graphite Black • Midnight Bronze • Serpentine • Titanium • Tungsten

h27mm (1 1/16") - Twin Motor

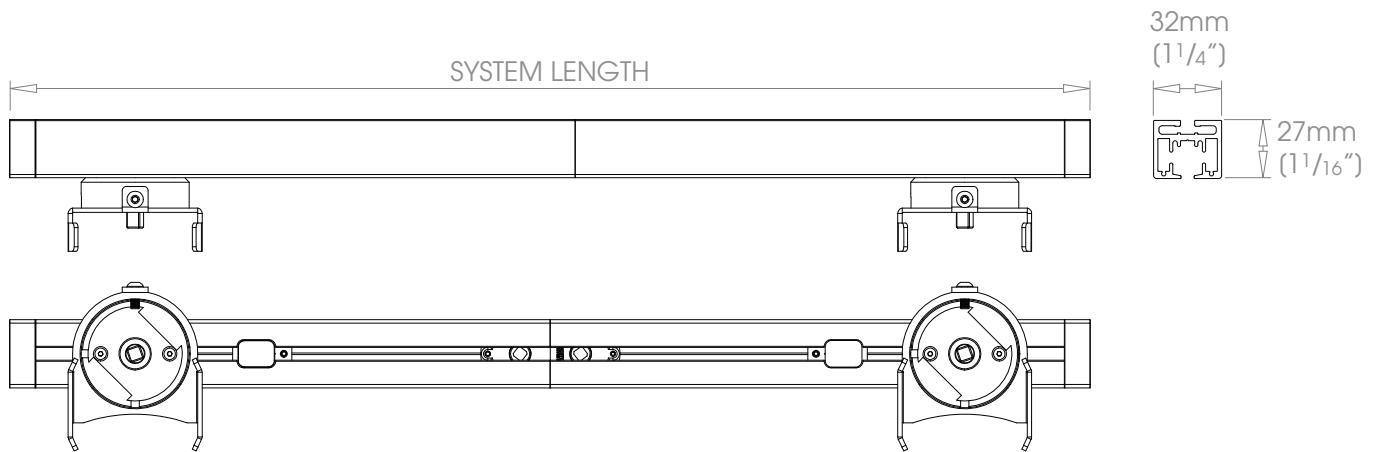

**Glider Options**

SINGLE STACK ▶ • PAIR STACK ▶◀



**GLIDER**  
Colour options:  
Gypsum • Anthracite



**SINE GLIDER**  
Colour options:  
Gypsum • Anthracite

Sine Pitch:  
80mm (3 1/8")

**Roller Options**

SINGLE STACK ▶ • PAIR STACK ▶◀



**ROLLER**  
Colour options:  
Gypsum • Anthracite



**SINE ROLLER**  
Colour options:  
Gypsum • Anthracite

Sine Pitch:  
60mm (2 3/8") • 80mm (3 1/8")



**METALCOAT ROLLER**  
Colour options:  
System ColourⓄ



**METALCOAT SINE ROLLER**  
Colour options:  
System ColourⓄ

Sine Pitch:  
60mm (2 3/8") • 80mm (3 1/8")



**METALCOAT RIPPLEFOLD ROLLER**  
Colour options:  
System ColourⓄ

Fullness:  
80% • 100%



**FINISHES**

Coat Options

- Matte ☹
- Satin ☹
- Gloss ☹

**Shades** ☹☹☹

Alabaster • Barley • Bone • Burnt Ash • Charcoal • Clay • Cloud • Cocoa • Cream • Dove • Dusk • Earth • Flint • Frame Grey • Grey Moss  
Lead • Millstone • Mineral • Moss • Oatmeal • Parchment • Raven • Smoke • Stone

**Metallics** ☹☹

Antique Brass • Bronzed • Champagne • Cognac • Gold • Gunmetal • Pewter • Platinum

**Anodics**

Glimmer • Glow • Midnight • Night Sky • Sky • Storm • Sunrise • Sunset • Twilight

**Organics**

Ash Stone • Iron • Obsidian • Sand Stone

**Ceramics**

*Available at +50% the cost of the standard finish* | Blue Titanium • Burnt Bronze • Cobalt • Copper • Electrum • Frost • Golden Quartz  
Graphite Black • Midnight Bronze • Serpentine • Titanium • Tungsten

h27mm (1 1/16") - Left Hand Motor

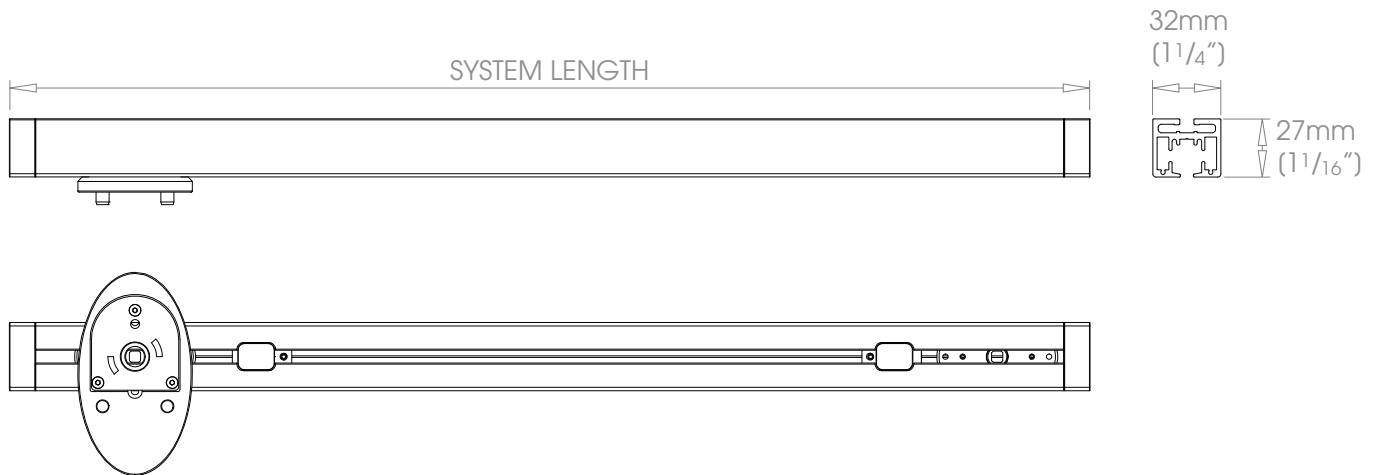

**Glider Options**

SINGLE STACK ► • PAIR STACK ►◄



**GLIDER**  
Colour options:  
Gypsum • Anthracite



**SINE GLIDER**  
Colour options:  
Gypsum • Anthracite

Sine Pitch:  
80mm (3 1/8")

**Roller Options**

SINGLE STACK ► • PAIR STACK ►◄



**ROLLER**  
Colour options:  
Gypsum • Anthracite



**SINE ROLLER**  
Colour options:  
Gypsum • Anthracite

Sine Pitch:  
60mm (2 3/8") • 80mm (3 1/8")



**METALCOAT ROLLER**  
Colour options:  
System Colour☹



**METALCOAT SINE ROLLER**  
Colour options:  
System Colour☹

Sine Pitch:  
60mm (2 3/8") • 80mm (3 1/8")



**METALCOAT RIPPLEFOLD ROLLER**  
Colour options:  
System Colour☹

Fullness:  
80% • 100%



**FINISHES**

Coat Options

- Matte Ⓞ
- Satin Ⓞ
- Gloss Ⓞ

**Shades** ⓄⓄⓄ

Alabaster • Barley • Bone • Burnt Ash • Charcoal • Clay • Cloud • Cocoa • Cream • Dove • Dusk • Earth • Flint • Frame Grey • Grey Moss Lead • Millstone • Mineral • Moss • Oatmeal • Parchment • Raven • Smoke • Stone

**Metallics** ⓄⓄ

Antique Brass • Bronzed • Champagne • Cognac • Gold • Gunmetal • Pewter • Platinum

**Anodics**

Glimmer • Glow • Midnight • Night Sky • Sky • Storm • Sunrise • Sunset • Twilight

**Organics**

Ash Stone • Iron • Obsidian • Sand Stone

**Ceramics**

*Available at +50% the cost of the standard finish* | Blue Titanium • Burnt Bronze • Cobalt • Copper • Electrum • Frost • Golden Quartz Graphite Black • Midnight Bronze • Serpentine • Titanium • Tungsten

h27mm (1 1/16") - Right Hand Motor

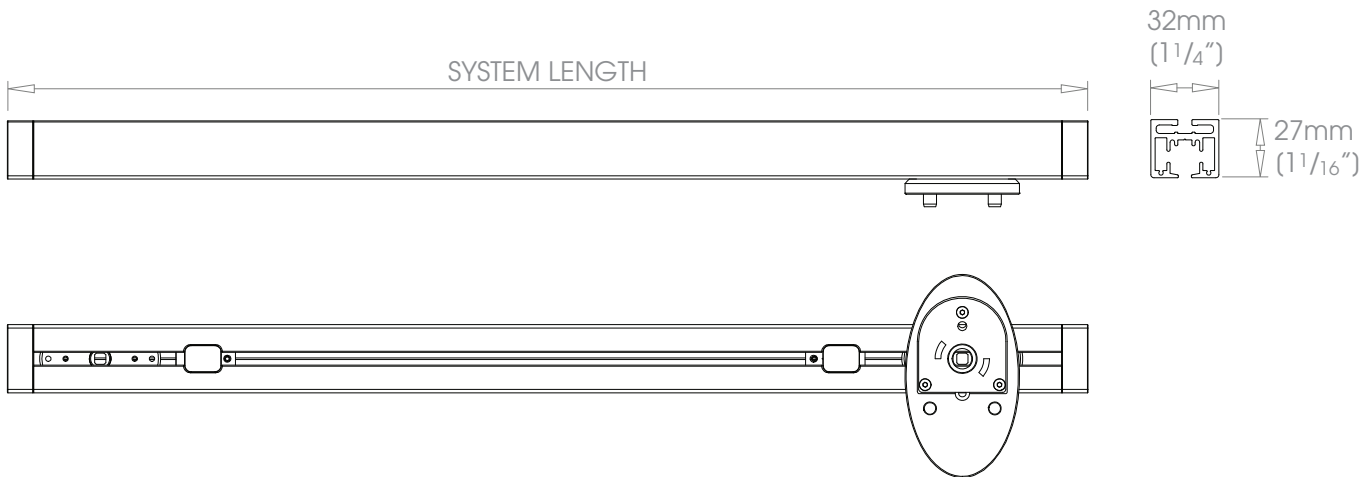

**Glider Options**

SINGLE STACK ▶ • PAIR STACK ▶◀



**GLIDER**

Colour options:  
Gypsum • Anthracite



**SINE GLIDER**

Colour options:  
Gypsum • Anthracite

Sine Pitch:  
80mm (3 1/8")

**Roller Options**

SINGLE STACK ▶ • PAIR STACK ▶◀



**ROLLER**

Colour options:  
Gypsum • Anthracite



**SINE ROLLER**

Colour options:  
Gypsum • Anthracite

Sine Pitch:  
60mm (2 3/8") • 80mm (3 1/8")



**METALCOAT ROLLER**

Colour options:  
System ColourⓄ



**METALCOAT SINE ROLLER**

Colour options:  
System ColourⓄ

Sine Pitch:  
60mm (2 3/8") • 80mm (3 1/8")



**METALCOAT RIPPLEFOLD ROLLER**

Colour options:  
System ColourⓄ

Fullness:  
80% • 100%

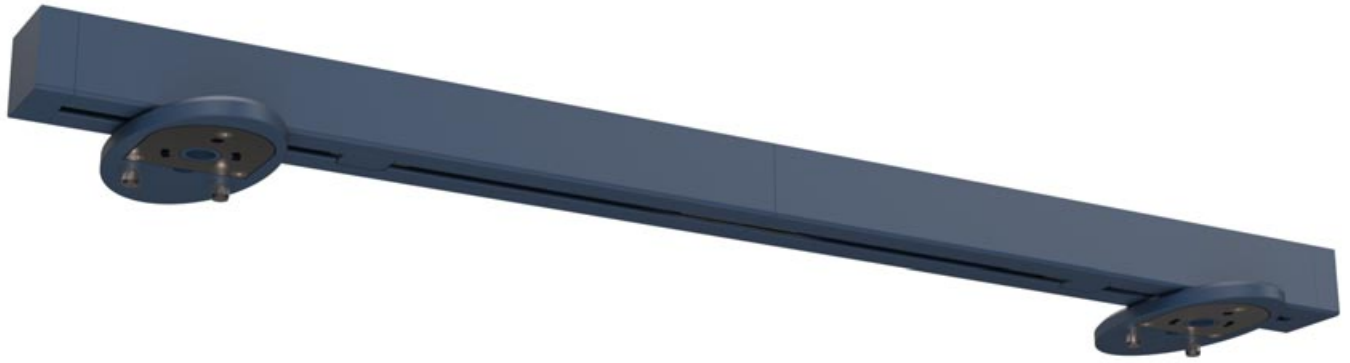

**FINISHES**

Coat Options

- Matte ☉
- Satin ☉
- Gloss ☉

**Shades** ☉☉☉

Alabaster • Barley • Bone • Burnt Ash • Charcoal • Clay • Cloud • Cocoa • Cream • Dove • Dusk • Earth • Flint • Frame Grey • Grey Moss  
Lead • Millstone • Mineral • Moss • Oatmeal • Parchment • Raven • Smoke • Stone

**Metallics** ☉☉

Antique Brass • Bronzed • Champagne • Cognac • Gold • Gunmetal • Pewter • Platinum

**Anodics**

Glimmer • Glow • Midnight • Night Sky • Sky • Storm • Sunrise • Sunset • Twilight

**Organics**

Ash Stone • Iron • Obsidian • Sand Stone

**Ceramics**

*Available at +50% the cost of the standard finish* | Blue Titanium • Burnt Bronze • Cobalt • Copper • Electrum • Frost • Golden Quartz  
Graphite Black • Midnight Bronze • Serpentine • Titanium • Tungsten

h27mm (1 1/16") - Twin Motor

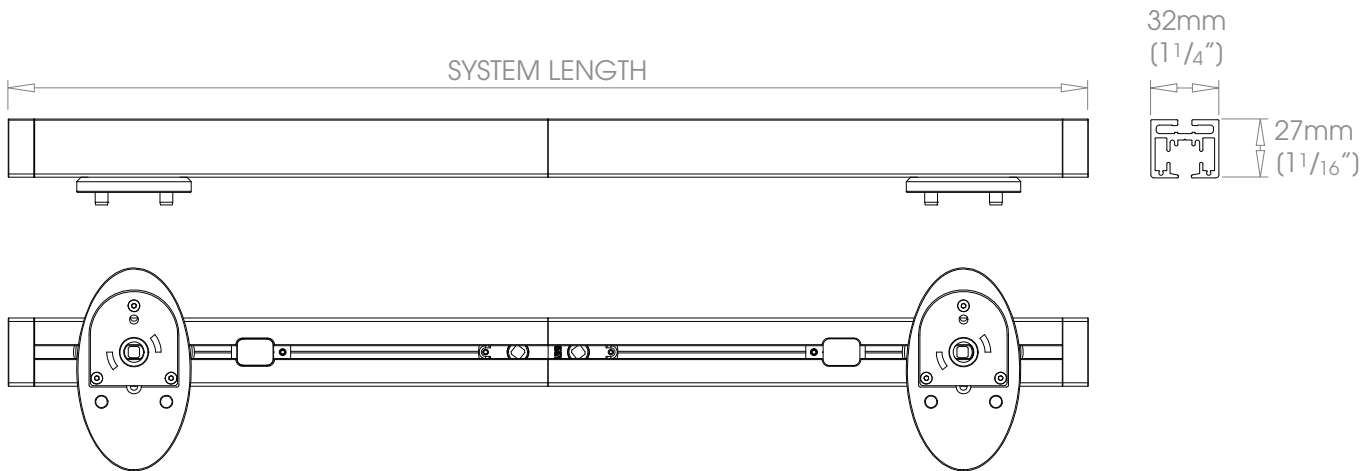

**Glider Options**

SINGLE STACK ► • PAIR STACK ►◄



**GLIDER**

Colour options:  
Gypsum • Anthracite



**SINE GLIDER**

Colour options:  
Gypsum • Anthracite

Sine Pitch:  
80mm (3 1/8")

**Roller Options**

SINGLE STACK ► • PAIR STACK ►◄



**ROLLER**

Colour options:  
Gypsum • Anthracite



**SINE ROLLER**

Colour options:  
Gypsum • Anthracite

Sine Pitch:  
60mm (2 3/8") • 80mm (3 1/8")



**METALCOAT ROLLER**

Colour options:  
System Colour☉



**METALCOAT SINE ROLLER**

Colour options:  
System Colour☉

Sine Pitch:  
60mm (2 3/8") • 80mm (3 1/8")



**METALCOAT RIPPLEFOLD ROLLER**

Colour options:  
System Colour☉

Fullness:  
80% • 100%



**FINISHES**

Coat Options  
Matte Ⓞ  
Satin Ⓞ  
Gloss Ⓞ

- Shades** ⓄⓄⓄ Alabaster • Barley • Bone • Burnt Ash • Charcoal • Clay • Cloud • Cocoa • Cream • Dove • Dusk • Earth • Flint • Frame Grey • Grey Moss  
Lead • Millstone • Mineral • Moss • Oatmeal • Parchment • Raven • Smoke • Stone  
**Metallics** ⓄⓄⓄ Antique Brass • Bronzed • Champagne • Cognac • Gold • Gunmetal • Pewter • Platinum  
**Anodics** ⓄⓄⓄ Glimmer • Glow • Midnight • Night Sky • Sky • Storm • Sunrise • Sunset • Twilight  
**Organics** ⓄⓄⓄ Ash Stone • Iron • Obsidian • Sand Stone  
**Ceramics** ⓄⓄⓄ Available at +50% the cost of the standard finish | Blue Titanium • Burnt Bronze • Cobalt • Copper • Electrum • Frost • Golden Quartz  
Graphite Black • Midnight Bronze • Serpentine • Titanium • Tungsten

h27mm (1 1/16") - Left Hand Motor

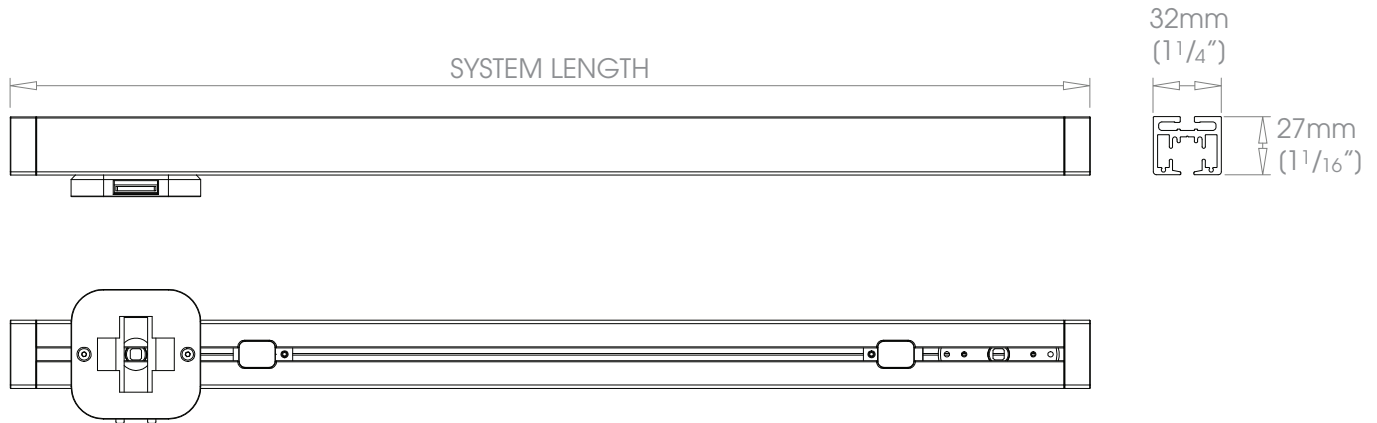

**Glider Options**

SINGLE STACK ▶ • PAIR STACK ▶◀



**GLIDER**  
Colour options:  
Gypsum • Anthracite



**SINE GLIDER**  
Colour options:  
Gypsum • Anthracite

Sine Pitch:  
80mm (3 1/8")

**Roller Options**

SINGLE STACK ▶ • PAIR STACK ▶◀



**ROLLER**  
Colour options:  
Gypsum • Anthracite



**SINE ROLLER**  
Colour options:  
Gypsum • Anthracite

Sine Pitch:  
60mm (2 3/8") • 80mm (3 1/8")



**METALCOAT ROLLER**  
Colour options:  
System ColourⓄ



**METALCOAT SINE ROLLER**  
Colour options:  
System ColourⓄ

Sine Pitch:  
60mm (2 3/8") • 80mm (3 1/8")



**METALCOAT RIPPLEFOLD ROLLER**  
Colour options:  
System ColourⓄ

Fullness:  
80% • 100%

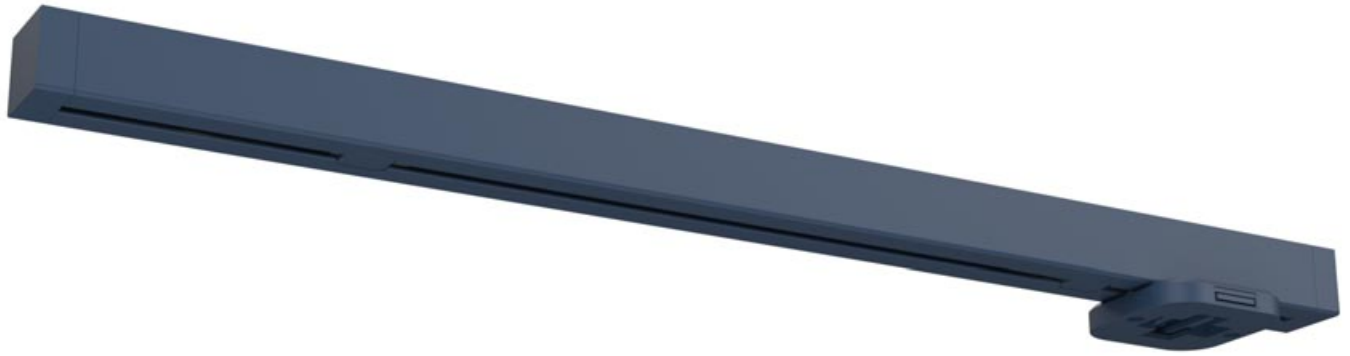

**FINISHES**

Coat Options

- Matte ①
- Satin ②
- Gloss ③

**Shades** ④⑤⑥

Alabaster • Barley • Bone • Burnt Ash • Charcoal • Clay • Cloud • Cocoa • Cream • Dove • Dusk • Earth • Flint • Frame Grey • Grey Moss  
Lead • Millstone • Mineral • Moss • Oatmeal • Parchment • Raven • Smoke • Stone

**Metallics** ⑦⑧

Antique Brass • Bronzed • Champagne • Cognac • Gold • Gunmetal • Pewter • Platinum

**Anodics**

Glimmer • Glow • Midnight • Night Sky • Sky • Storm • Sunrise • Sunset • Twilight

**Organics**

Ash Stone • Iron • Obsidian • Sand Stone

**Ceramics**

*Available at +50% the cost of the standard finish* | Blue Titanium • Burnt Bronze • Cobalt • Copper • Electrum • Frost • Golden Quartz  
Graphite Black • Midnight Bronze • Serpentine • Titanium • Tungsten

h27mm (1 1/16") - Right Hand Motor

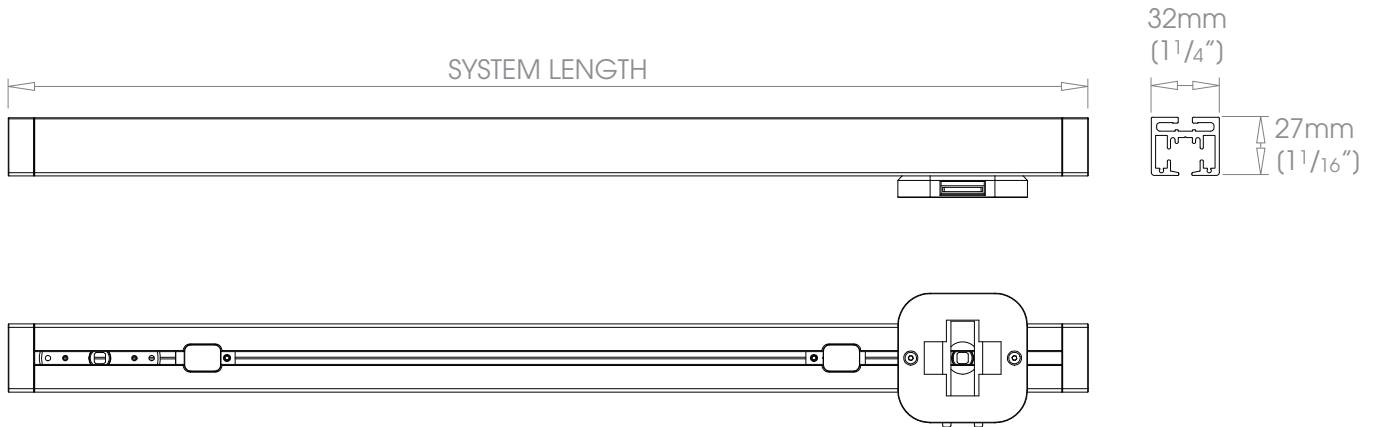

**Glider Options**

SINGLE STACK ▶ • PAIR STACK ▶◀



**GLIDER**

Colour options:  
Gypsum • Anthracite



**SINE GLIDER**

Colour options:  
Gypsum • Anthracite

Sine Pitch:  
80mm (3 1/8")

**Roller Options**

SINGLE STACK ▶ • PAIR STACK ▶◀



**ROLLER**

Colour options:  
Gypsum • Anthracite



**SINE ROLLER**

Colour options:  
Gypsum • Anthracite

Sine Pitch:  
60mm (2 3/8") • 80mm (3 1/8")



**METALCOAT ROLLER**

Colour options:  
System Colour®



**METALCOAT SINE ROLLER**

Colour options:  
System Colour®

Sine Pitch:  
60mm (2 3/8") • 80mm (3 1/8")



**METALCOAT RIPPLEFOLD ROLLER**

Colour options:  
System Colour®

Fullness:  
80% • 100%

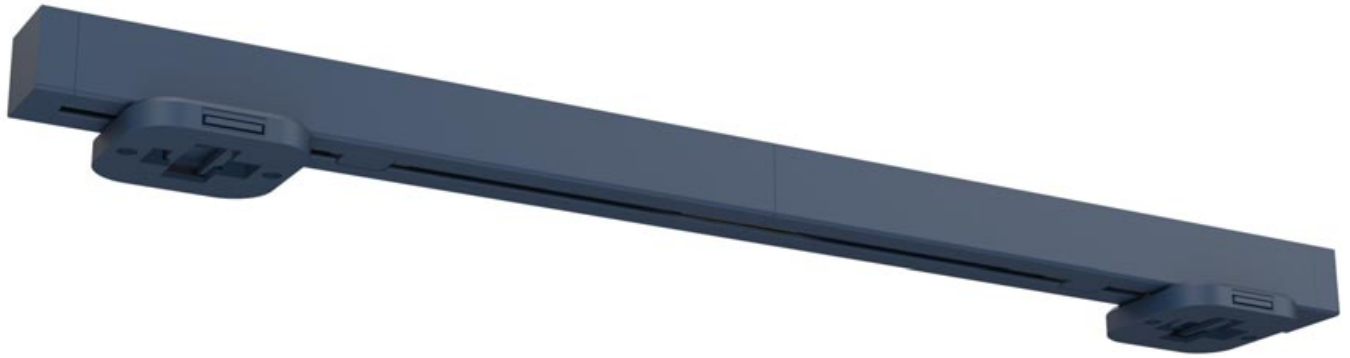

**FINISHES**

**Coat Options**

- Matte ☉
- Satin ☉
- Gloss ☉

- Shades** ☉☉☉
- Metallics** ☉☉
- Anodics** ☉☉
- Organics** ☉☉
- Ceramics** ☉☉

Alabaster • Barley • Bone • Burnt Ash • Charcoal • Clay • Cloud • Cocoa • Cream • Dove • Dusk • Earth • Flint • Frame Grey • Grey Moss  
 Lead • Millstone • Mineral • Moss • Oatmeal • Parchment • Raven • Smoke • Stone  
 Antique Brass • Bronzed • Champagne • Cognac • Gold • Gunmetal • Pewter • Platinum  
 Glimmer • Glow • Midnight • Night Sky • Sky • Storm • Sunrise • Sunset • Twilight  
 Ash Stone • Iron • Obsidian • Sand Stone  
*Available at +50% the cost of the standard finish* | Blue Titanium • Burnt Bronze • Cobalt • Copper • Electrum • Frost • Golden Quartz  
 Graphite Black • Midnight Bronze • Serpentine • Titanium • Tungsten

h27mm (1 1/16") - Twin Motor

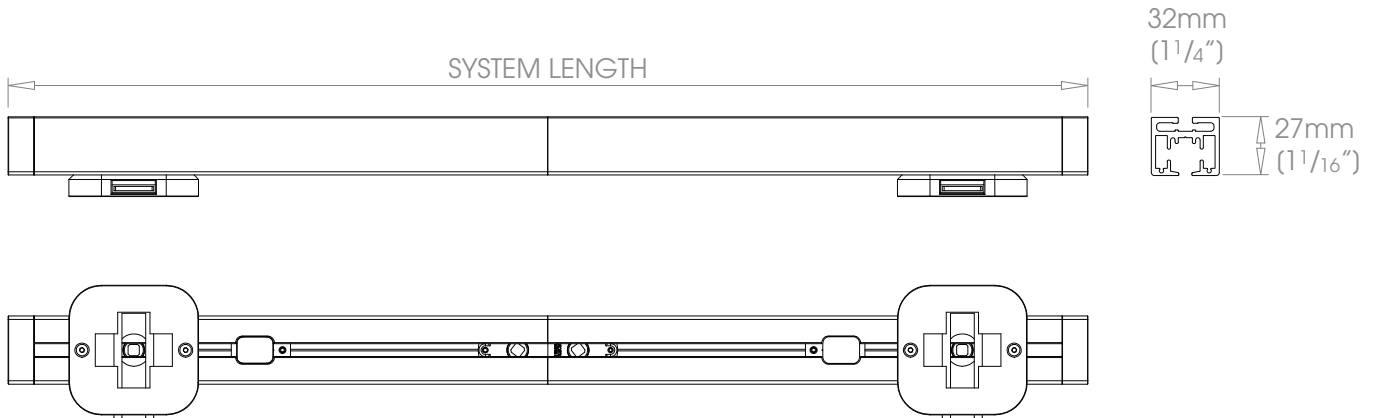

**Glider Options**

SINGLE STACK ► • PAIR STACK ►◄



**GLIDER**  
 Colour options:  
 Gypsum • Anthracite



**SINE GLIDER**  
 Colour options:  
 Gypsum • Anthracite

Sine Pitch:  
 80mm (3 1/8")

**Roller Options**

SINGLE STACK ► • PAIR STACK ►◄



**ROLLER**  
 Colour options:  
 Gypsum • Anthracite



**SINE ROLLER**  
 Colour options:  
 Gypsum • Anthracite

Sine Pitch:  
 60mm (2 3/8") • 80mm (3 1/8")



**METALCOAT ROLLER**  
 Colour options:  
 System Colour☉



**METALCOAT SINE ROLLER**  
 Colour options:  
 System Colour☉

Sine Pitch:  
 60mm (2 3/8") • 80mm (3 1/8")



**METALCOAT RIPPLEFOLD ROLLER**  
 Colour options:  
 System Colour☉

Fullness:  
 80% • 100%



⚠ Return bends are not available.

**FINISHES**

**Coat Options**  
 Matte Ⓜ  
 Satin Ⓢ  
 Gloss ⓖ

**Shades** ⓂⓈⓖ  
**Metals** ⓂⓈⓖ  
**Anodics** ⓂⓈⓖ  
**Organics**  
**Ceramics**

Alabaster • Barley • Bone • Burnt Ash • Charcoal • Clay • Cloud • Cocoa • Cream • Dove • Dusk • Earth • Flint • Frame Grey • Grey Moss  
 Lead • Millstone • Mineral • Moss • Oatmeal • Parchment • Raven • Smoke • Stone  
 Antique Brass • Bronzed • Champagne • Cognac • Gold • Gunmetal • Pewter • Platinum  
 Glimmer • Glow • Midnight • Night Sky • Sky • Storm • Sunrise • Sunset • Twilight  
 Ash Stone • Iron • Obsidian • Sand Stone  
*Available at +50% the cost of the standard finish* | Blue Titanium • Burnt Bronze • Cobalt • Copper • Electrum • Frost • Golden Quartz  
 Graphite Black • Midnight Bronze • Serpentine • Titanium • Tungsten

h27mm (1 1/16")

BEND RADIUS  
 275mm  
 (10 13/16")

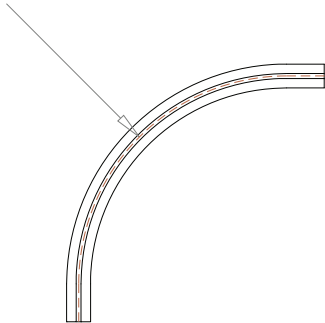



**FINISHES**

**Coat Options**

- Matte ⊕
- Satin ⊕
- Gloss ⊕

**Shades** ⊕⊕⊕

- Metallics** ⊕⊕
- Anodics** ⊕⊕
- Organics**
- Ceramics**

Alabaster • Barley • Bone • Burnt Ash • Charcoal • Clay • Cloud • Cocoa • Cream • Dove • Dusk • Earth • Flint • Frame Grey • Grey Moss  
 Lead • Millstone • Mineral • Moss • Oatmeal • Parchment • Raven • Smoke • Stone  
 Antique Brass • Bronzed • Champagne • Cognac • Gold • Gunmetal • Pewter • Platinum  
 Glimmer • Glow • Midnight • Night Sky • Sky • Storm • Sunrise • Sunset • Twilight  
 Ash Stone • Iron • Obsidian • Sand Stone  
*Available at +50% the cost of the standard finish* | Blue Titanium • Burnt Bronze • Cobalt • Copper • Electrum • Frost • Golden Quartz  
 Graphite Black • Midnight Bronze • Serpentine • Titanium • Tungsten

h27mm (1 1/16")

300mm (12")

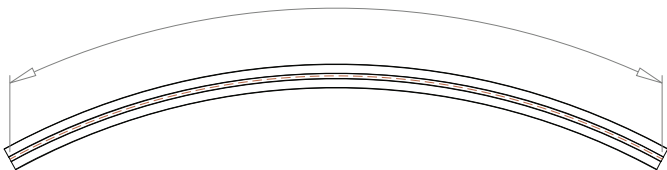



⚠ Motor and Return Cartridges can be positioned at the mitre.  
 Highlighted grey area is a non running space.

- FINISHES**
- Shades** ☉☉☉ Alabaster • Barley • Bone • Burnt Ash • Charcoal • Clay • Cloud • Cocoa • Cream • Dove • Dusk • Earth • Flint • Frame Grey • Grey Moss • Lead • Millstone • Mineral • Moss • Oatmeal • Parchment • Raven • Smoke • Stone
  - Coat Options**
  - Matte** ☉
  - Satin** ☉
  - Gloss** ☉
  - Metallics** ☉☉ Antique Brass • Bronzed • Champagne • Cognac • Gold • Gunmetal • Pewter • Platinum
  - Anodics** ☉☉ Glimmer • Glow • Midnight • Night Sky • Sky • Storm • Sunrise • Sunset • Twilight
  - Organics** Ash Stone • Iron • Obsidian • Sand Stone
  - Ceramics** *Available at +50% the cost of the standard finish* | Blue Titanium • Burnt Bronze • Cobalt • Copper • Electrum • Frost • Golden Quartz • Graphite Black • Midnight Bronze • Serpentine • Titanium • Tungsten

h27mm (1 1/16") - Motor Cartridges

h27mm (1 1/16") - Return Cartridges

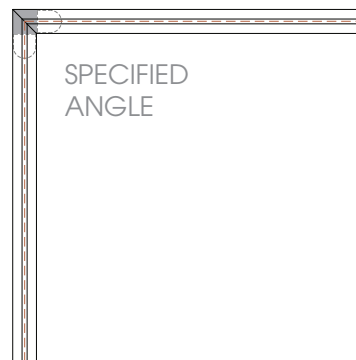
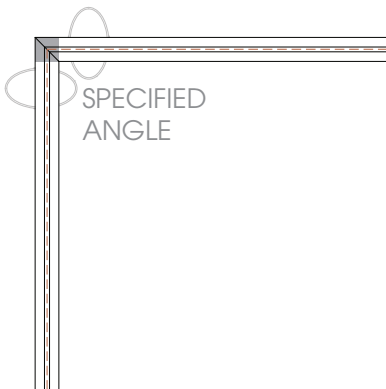





 Customised brackets available - See page 9

- FINISHES** **Shades** @@@ Alabaster • Barley • Bone • Burnt Ash • Charcoal • Clay • Cloud • Cocoa • Cream • Dove • Dusk • Earth • Flint • Frame Grey • Grey Moss  
 Lead • Millstone • Mineral • Moss • Oatmeal • Parchment • Raven • Smoke • Stone  
**Coat Options** **Metallics** @@ Antique Brass • Bronzed • Champagne • Cognac • Gold • Gunmetal • Pewter • Platinum  
**Matte** @ **Anodics** @@@ Glimmer • Glow • Midnight • Night Sky • Sky • Storm • Sunrise • Sunset • Twilight  
**Satin** @ **Organics** Ash Stone • Iron • Obsidian • Sand Stone  
**Gloss** @ **Ceramics** *Available at +50% the cost of the standard finish* | Blue Titanium • Burnt Bronze • Cobalt • Copper • Electrum • Frost • Golden Quartz  
 Graphite Black • Midnight Bronze • Serpentine • Titanium • Tungsten

h27mm (1 1/16")

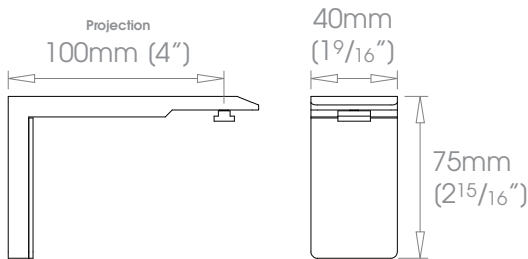



 Customised brackets available - See page 9

- FINISHES** **Shades** ☉☉☉ Alabaster • Barley • Bone • Burnt Ash • Charcoal • Clay • Cloud • Cocoa • Cream • Dove • Dusk • Earth • Flint • Frame Grey • Grey Moss  
 Lead • Millstone • Mineral • Moss • Oatmeal • Parchment • Raven • Smoke • Stone  
**Coat Options** **Metallics** ☉☉ Antique Brass • Bronzed • Champagne • Cognac • Gold • Gunmetal • Pewter • Platinum  
 Matte ☉ **Anodics** ☉☉ Glimmer • Glow • Midnight • Night Sky • Sky • Storm • Sunrise • Sunset • Twilight  
 Satin ☉ **Organics** Ash Stone • Iron • Obsidian • Sand Stone  
 Gloss ☉ **Ceramics** *Available at +50% the cost of the standard finish* | Blue Titanium • Burnt Bronze • Cobalt • Copper • Electrum • Frost • Golden Quartz  
 Graphite Black • Midnight Bronze • Serpentine • Titanium • Tungsten

h27mm (1 1/16")

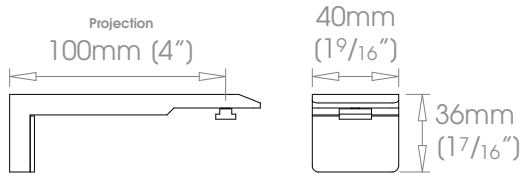

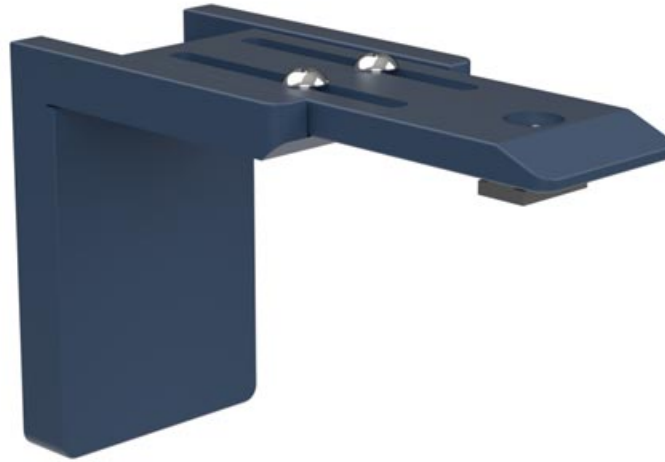

**FINISHES**

Coat Options  
Matte @  
Satin @  
Gloss @

**Shades** @@@  
**Metallics** @@@  
**Anodics** @@@  
**Organics**  
**Ceramics**

Alabaster • Barley • Bone • Burnt Ash • Charcoal • Clay • Cloud • Cocoa • Cream • Dove • Dusk • Earth • Flint • Frame Grey • Grey Moss  
Lead • Millstone • Mineral • Moss • Oatmeal • Parchment • Raven • Smoke • Stone  
Antique Brass • Bronzed • Champagne • Cognac • Gold • Gunmetal • Pewter • Platinum  
Glimmer • Glow • Midnight • Night Sky • Sky • Storm • Sunrise • Sunset • Twilight  
Ash Stone • Iron • Obsidian • Sand Stone  
*Available at +50% the cost of the standard finish* | Blue Titanium • Burnt Bronze • Cobalt • Copper • Electrum • Frost • Golden Quartz  
Graphite Black • Midnight Bronze • Serpentine • Titanium • Tungsten

**h27mm (1 1/16")**

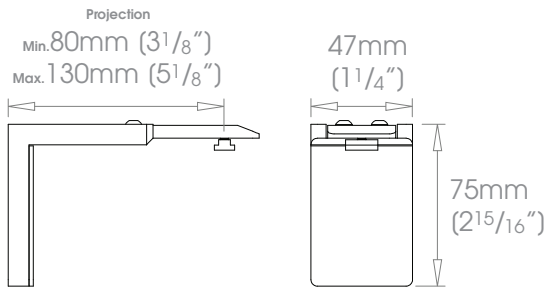



- FINISHES** **Shades** ☉☉☉ Alabaster • Barley • Bone • Burnt Ash • Charcoal • Clay • Cloud • Cocoa • Cream • Dove • Dusk • Earth • Flint • Frame Grey • Grey Moss  
 Lead • Millstone • Mineral • Moss • Oatmeal • Parchment • Raven • Smoke • Stone  
**Coat Options** **Metallics** ☉☉ Antique Brass • Bronzed • Champagne • Cognac • Gold • Gunmetal • Pewter • Platinum  
**Matte** ☉ **Anodics** ☉☉ Glimmer • Glow • Midnight • Night Sky • Sky • Storm • Sunrise • Sunset • Twilight  
**Satin** ☉ **Organics** Ash Stone • Iron • Obsidian • Sand Stone  
**Gloss** ☉ **Ceramics** *Available at +50% the cost of the standard finish* | Blue Titanium • Burnt Bronze • Cobalt • Copper • Electrum • Frost • Golden Quartz  
 Graphite Black • Midnight Bronze • Serpentine • Titanium • Tungsten

h27mm (1 1/16")

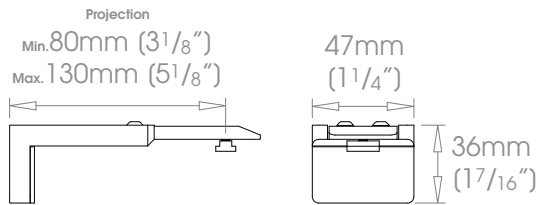

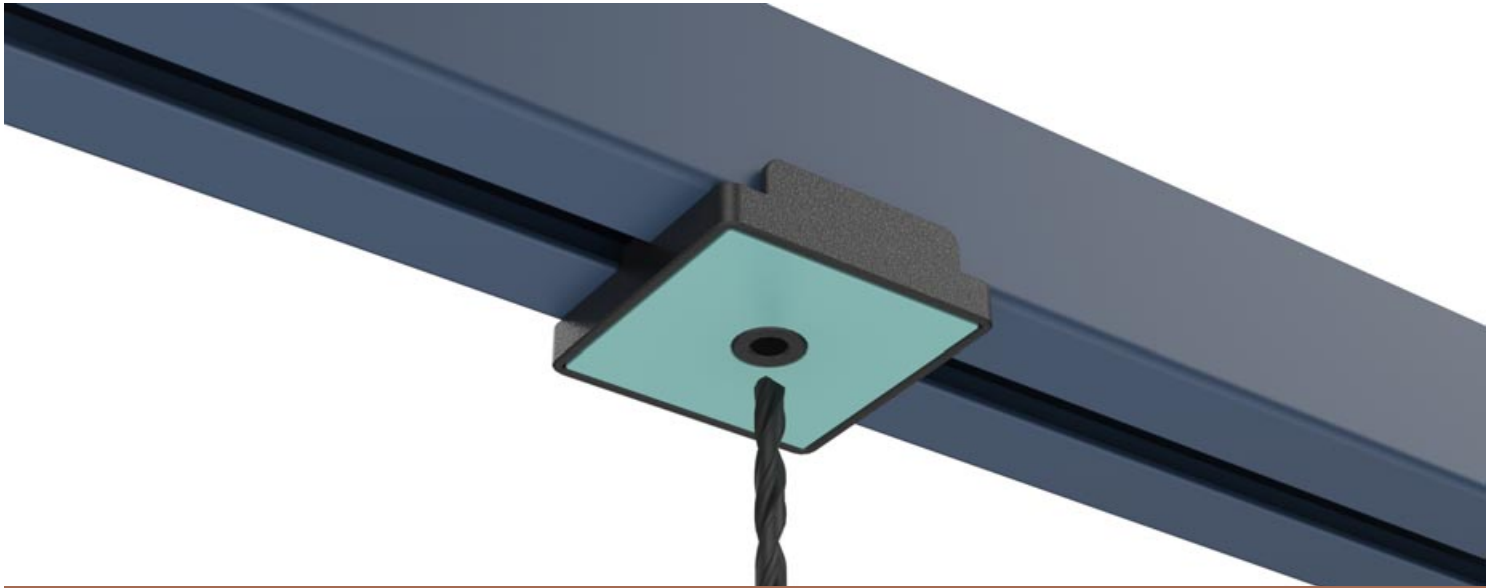

For direct ceiling fit

### KIT INCLUDES

- Track Protection Gauge
- 3.3mm (1/8") Drill Bit
- Self Tapping Screws

**1** Prepare



**2** Protect



**3** Drill



**4** Clean



**5** Secure





**!** Recess brackets are not suitable for use with flush ceiling brackets

- FINISHES**
- |                     |  |
|---------------------|--|
| <b>Shades</b> ☉☉☉   | Alabaster • Barley • Bone • Burnt Ash • Charcoal • Clay • Cloud • Cocoa • Cream • Dove • Dusk • Earth • Flint • Frame Grey • Grey Moss • Lead • Millstone • Mineral • Moss • Oatmeal • Parchment • Raven • Smoke • Stone |
| <b>Coat Options</b> |  |
| Matte ☉             | <b>Metallics</b> ☉☉  |
| Satin ☉             | Antique Brass • Bronzed • Champagne • Cognac • Gold • Gunmetal • Pewter • Platinum   |
| Gloss ☉             | <b>Anodics</b> ☉☉  |
|                     | Glimmer • Glow • Midnight • Night Sky • Sky • Storm • Sunrise • Sunset • Twilight  |
|                     | <b>Organics</b>  |
|                     | Ash Stone • Iron • Obsidian • Sand Stone   |
|                     | <b>Ceramics</b>  |
|                     | <i>Available at +50% the cost of the standard finish</i>   Blue Titanium • Burnt Bronze • Cobalt • Copper • Electrum • Frost • Golden Quartz • Graphite Black • Midnight Bronze • Serpentine • Titanium • Tungsten       |

H27mm (1 1/16")

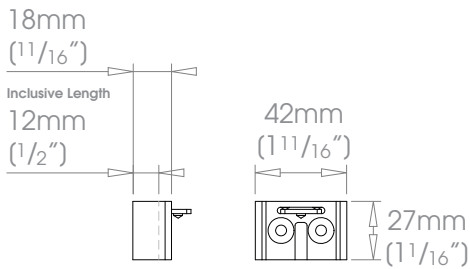

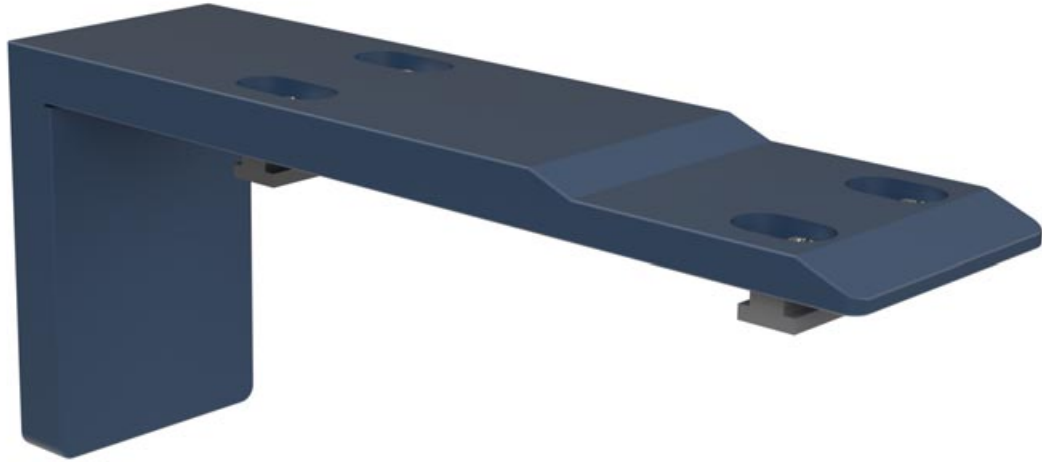

**FINISHES** **Shades** ☉☉☉ Alabaster • Barley • Bone • Burnt Ash • Charcoal • Clay • Cloud • Cocoa • Cream • Dove • Dusk • Earth • Flint • Frame Grey • Grey Moss  
 Lead • Millstone • Mineral • Moss • Oatmeal • Parchment • Raven • Smoke • Stone  
**Coat Options** **Metallics** ☉☉ Antiqued Brass • Bronzed • Champagne • Cognac • Gold • Gunmetal • Pewter • Platinum  
**Matte** ☉ **Anodics** ☉☉ Glimmer • Glow • Midnight • Night Sky • Sky • Storm • Sunrise • Sunset • Twilight  
**Satin** ☉ **Organics** Ash Stone • Iron • Obsidian • Sand Stone  
**Gloss** ☉ **Ceramics** Available at +50% the cost of the standard finish | Blue Titanium • Burnt Bronze • Cobalt • Copper • Electrum • Frost • Golden Quartz  
 Graphite Black • Midnight Bronze • Serpentine • Titanium • Tungsten

**FRONT H27mm (1 1/16") BACK H27mm (1 1/16")**

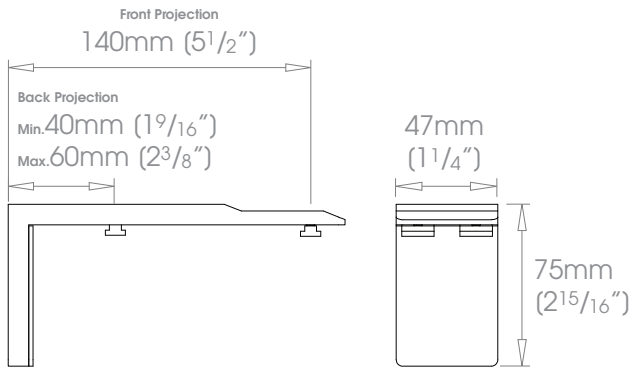

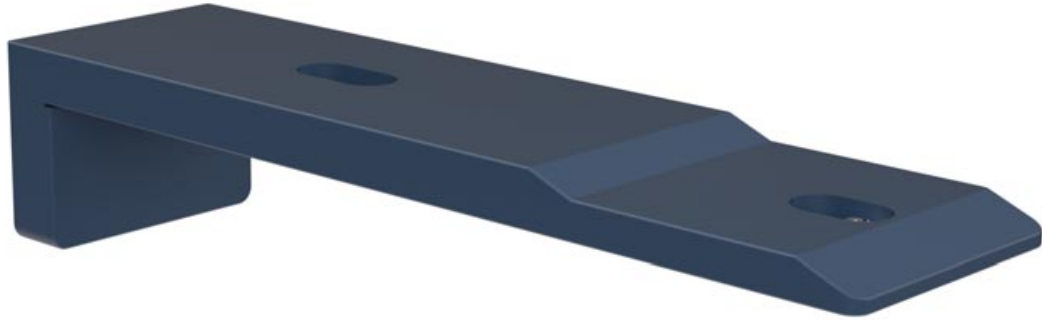

**FINISHES** **Shades** ☉☉☉ Alabaster • Barley • Bone • Burnt Ash • Charcoal • Clay • Cloud • Cocoa • Cream • Dove • Dusk • Earth • Flint • Frame Grey • Grey Moss  
 Lead • Millstone • Mineral • Moss • Oatmeal • Parchment • Raven • Smoke • Stone  
**Coat Options** **Metallics** ☉☉ Antique Brass • Bronzed • Champagne • Cognac • Gold • Gunmetal • Pewter • Platinum  
**Matte** ☉ **Anodics** ☉☉ Glimmer • Glow • Midnight • Night Sky • Sky • Storm • Sunrise • Sunset • Twilight  
**Satin** ☉ **Organics** Ash Stone • Iron • Obsidian • Sand Stone  
**Gloss** ☉ **Ceramics** Available at +50% the cost of the standard finish | Blue Titanium • Burnt Bronze • Cobalt • Copper • Electrum • Frost • Golden Quartz  
 Graphite Black • Midnight Bronze • Serpentine • Titanium • Tungsten

**FRONT H27mm (1 1/16") BACK H27mm (1 1/16")**

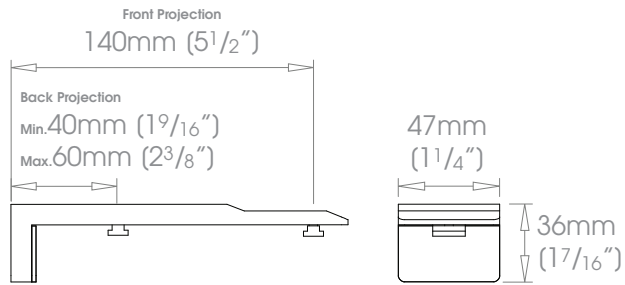

# CONTACT

[www.bradleycollection.com](http://www.bradleycollection.com)



## UK & REST OF THE WORLD

☎ +44 (0)1449 722 724

✉ [info@bradleycollection.com](mailto:info@bradleycollection.com)

## USA & CANADA

☎ +1 (310) 815 8255

✉ [info.us@bradleycollection.com](mailto:info.us@bradleycollection.com)

---

## LONDON SHOWROOM

☎ +44 (0)207 871 7793

✉ [showroom@studiotwochelsea.com](mailto:showroom@studiotwochelsea.com)

## THE BRADLEY COLLECTION



**Industry Partner**

Supporting the interior design profession

CEDIA  
MEMBER

Specialised fixings for mounting brackets will be required in certain situations and are not provided as standard. Steel items are not recommended for damp conditions such as shower rooms. Crystal finials should not be positioned in direct sunlight, and are not suitable for use in conservatories.

The Bradley Collection reserves the right to modify design and materials without prior notice as part of a process of continual product improvement. Due to printing limitations, colours in this brochure may not be accurate.

Products are protected by Design Rights, under provisions of Copyright, Designs & Patents Act 1988. Bradley® and The Bradley Collection® are registered Community trademarks of The Bradley Collection Ltd. in Europe and registered trademarks of the Bradley Collection, Inc. in the USA. Gliderpole is a registered trademark of The Bradley Collection Ltd in the UK.

**The Bradley Collection Ltd** Lion Barn • Maitland Road • Needham Market • Suffolk • IP6 8NS • UK  
**The Bradley Collection Inc** 10866 Washington Blvd #1275 • Culver City • CA 90232 • USA

Published: 0626 • Copyright © The Bradley Collection Ltd. 2026